

## DCRM distance coded reference mark system

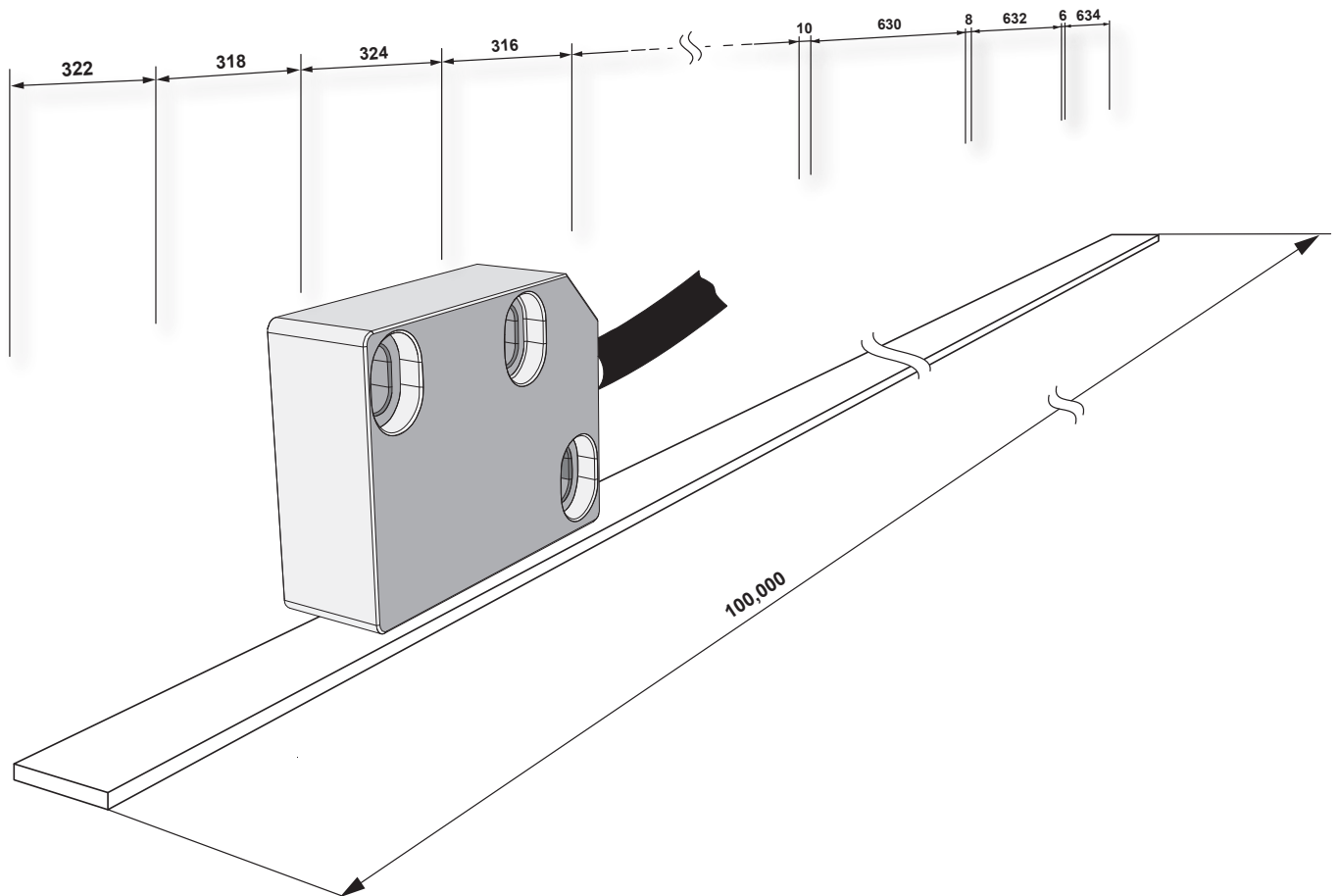

The distance coded reference mark (DCRM) scale allows a measuring system to re-establish absolute position after traversing a short travel. It represents a great usage benefit especially on long axis (several tens of meters), in comparison with conventional reference marks, where re-establishing of absolute position can require traversing the entire axis.

The distance coding is created by having multiple reference marks individually spaced according to mathematical algorithm. Absolute position is known after traversing 2 successive reference marks.

Absolute position of 1<sup>st</sup> traversed reference mark is calculated in controller electronics, based on relative distance between 2 neighbouring reference marks, direction of movement, basic increment, and magnetisation pole length. DCRM is currently available with 2 mm and 5 mm pole lengths.

- Customer selectable basic increment for optimal maximum length selection
- Compatible with standard RLS<sup>®</sup> LM10, LM13 and LM15 readheads
- Available for MS10 and MS15 magnetic scales
- Vertical / horizontal transport application

## Glossary

**Basic increment (K in mm)** - Represents the distance in mm between odd reference marks; it determines the maximum codable length over which the absolute position can be defined. It also determines the minimum distance which needs to be traversed to capture 2 neighbouring reference marks. The basic distance should be divisible by the length of 2 poles (in mm). **K** is customer selectable.

**Maximum codable length (L<sub>max</sub> in mm)** - Is the maximum length of the magnetic scale over which the DCRM feature can be applied and still provide a unique absolute position. Lengths shorter than the maximum length can also be used (see Table 1).

**Pole length (P in mm)** - Is the length of one magnetised pole (S or N). We currently offer magnetic scales with pole lengths 2 mm (MS10) and 5 mm (MS15).

## Specification

The basic increment K (in mm) is chosen at the point of order and must be divisible by 2 × P with no remainder. **K** determines:

- **Maximum codable length:**

$$L_{\max} = K \left( \frac{K}{2P} - 1 \right) - 2P$$

Where:

L<sub>max</sub> = Maximum codable length (in mm)  
**K** = Basic increment (in mm)  
**P** = Pole length (in mm)

- **Minimum distance along the measuring scale** which needs to be traversed in order to calculate the absolute position. The minimum travel distance equals the basic increment **K - 2P**.

The distribution of the reference marks is shown in figure 1. DCRMs are produced by additional magnetisation of the magnetic tape.

Figure 1

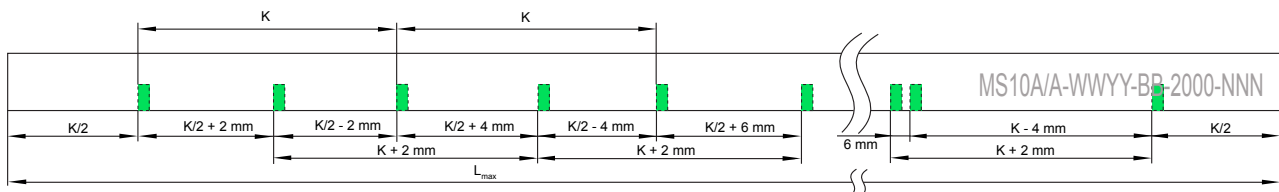

Table 1

K (mm)	Maximum codable length (mm)	
	P = 2 mm	P = 5 mm
20	76	
40	356	
60	836	
80	1,516	
100	2,396	890
200	9,796	3,790
300	22,196	8,690
400	39,596	15,590
500	61,996	24,490
600	89,396	35,390
700		48,290
800		63,190
900		80,090
1,000		98,990

## How the absolute position is evaluated

The absolute position of the 1<sup>st</sup> traversed reference mark is calculated by the following formula:

$$RI1 = \left[ \frac{1}{P} \times \text{abs}(2 \times \Delta RI - K) - \text{sgn}(2 \times \Delta RI - K) - 1 \right] \times \frac{K}{2} + [\text{sgn}(2 \times \Delta RI - K) - \text{sgn}(D)] \times \frac{\text{abs} \times \Delta RI}{2}$$

Where:

### Variables:

- RI1** = Absolute position of first traversed reference mark (in mm)
- ΔRI** = Distance between two successively traversed reference marks (in mm)
- K** = Basic increment between two fixed reference marks (in mm)
- D** = Direction of movement (+1 or -1)

### Operators:

- abs** = Absolute value;
- sgn** = Sign function (+1 or -1)

## Other considerations

### Timing of reference mark capturing

The minimum distance between 2 successive reference marks equals  $3 \times P$ . Subsequent electronics must be able to capture position of 2 successive reference marks under the maximum velocity condition. Minimum time at which 2 successive reference marks appear is given by formula:

$$T_{Rimin} = \frac{3P}{V_{max}}$$

Where:

- T<sub>Rimin</sub>** = Minimum time between 2 successive reference marks (in ms)
- P** = Pole length (in mm)
- v<sub>max</sub>** = Maximum traverse velocity (in m/s)

### Installation

It is recommended that the readhead is installed so that the ride height is smaller than 1/2 of the pole length (1/2P). Angular misalignment and lateral offset should be as close as possible to nominal values.

### The DCRM is compatible with the TRS track system

The TRS track system is a carrier-type system for applications that require the scale to be installed/removed for transit, or simply for any application where thermal expansion of the scale must be independent of the machine structure. See TRS track system data sheet (LM10D18) for more information.



## Distance coded reference mark part numbering

### Magnetic scales

#### MS10 or MS15

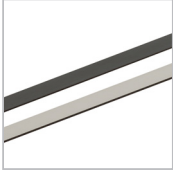

Please choose the appropriate MS magnetic scale with the "Dxxx - Distance coded reference mark" option selected.

**NOTE:** The LM10 and LM13 readheads can be used with the MS10 scale, the LM15 can only be used with the MS15 scale.

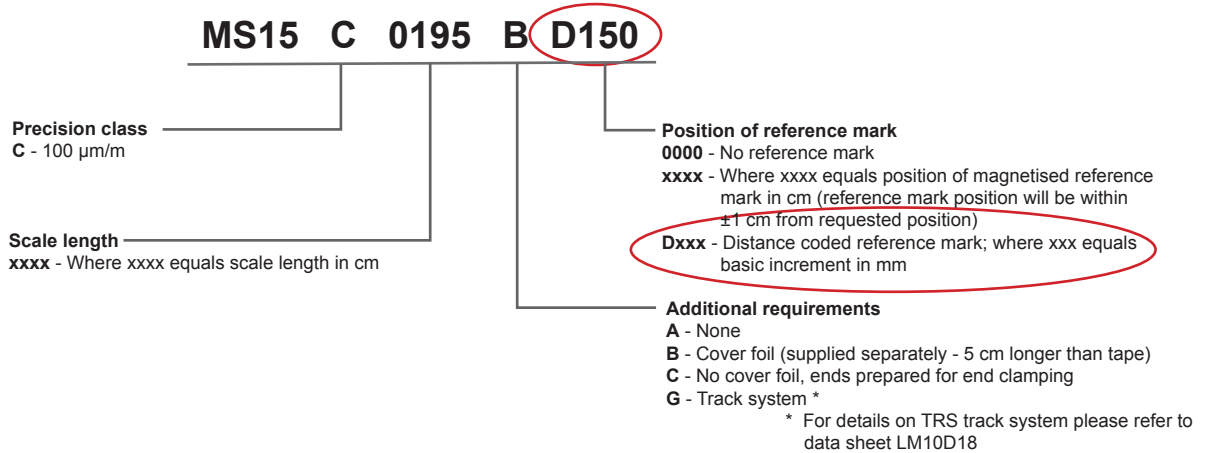
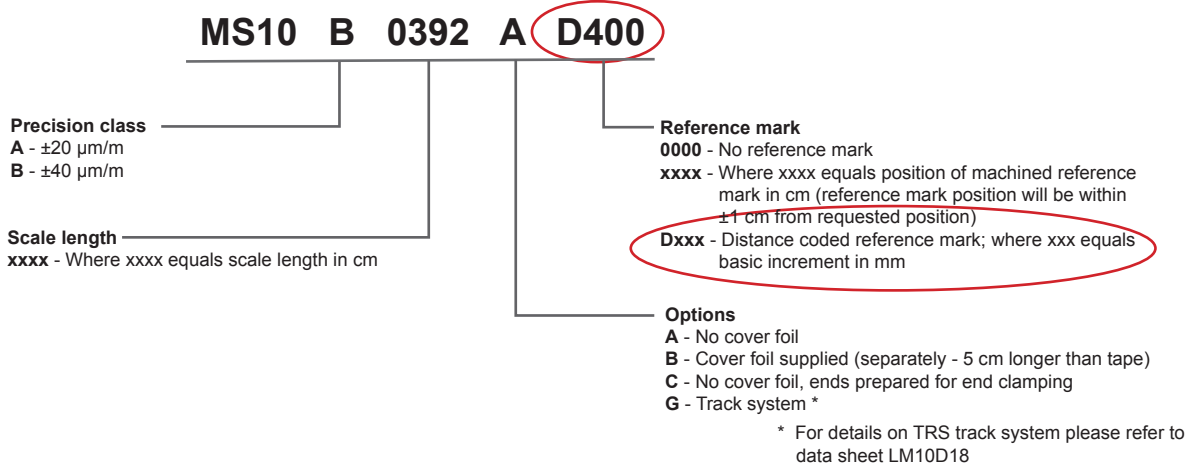

### Readheads

Please make sure that where "Reference" is defined, option A "With reference" is chosen.

#### LM10, LM15



or



LM13

Example:

**LM10 IC 010 C A 10 F 00**

**Reference**  
A - With reference  
B - No reference  
C - Periodic as per scale pitch (2 mm)

**NOTE:** Please check the LM10, LM13 or LM15 data sheet for a complete part numbering.

## Head office

---

### RLS merilna tehnika d.o.o.

Poslovna cona Žeje pri Komendi  
Pod vrbami 2  
SI-1218 Komenda  
Slovenia

**T** +386 1 5272100

**F** +386 1 5272129

**E** [mail@rls.si](mailto:mail@rls.si)

**www.rls.si**

## Document issues

Issue	Date	Page	Corrections made
1	7. 12. 2009	-	New document
2	12. 4. 2011	2	Maximum codable length formula and table changed

This product is not designed or intended for use outside the environmental limitations and operating parameters expressly stated on the product's datasheet. Products are not designed or intended for use in medical, military, aerospace, automotive or oil & gas applications or any safety-critical applications where a failure of the product could cause severe environmental or property damage, personal injury or death. Any use in such applications must be specifically agreed to by seller in writing, and is subject to such additional terms as the seller may impose in its sole discretion. Use of products in such applications is at buyer's own risk, and buyer will indemnify and hold harmless seller and its affiliates against any liability, loss, damage or expense arising from such use. Information contained in this datasheet was derived from product testing under controlled laboratory conditions and data reported thereon is subject to the stated tolerances and variations, or if none are stated, then to tolerances and variations consistent with usual trade practices and testing methods. The product's performance outside of laboratory conditions, including when one or more operating parameters is at its maximum range, may not conform to the product's datasheet. Further, information in the product's datasheet does not reflect the performance of the product in any application, end-use or operating environment buyer or its customer may put the product to. Seller and its affiliates make no recommendation, warranty or representation as to the suitability of the product for buyer's application, use, end-product, process or combination with any other product or as to any results buyer or its customer might obtain in their use of the product. Buyer should use its own knowledge, judgment, expertise and testing in selecting the product for buyer's application, end-use and/or operating environment, and should not rely on any oral or written statement, representation, or samples made by seller or its affiliates for any purpose. EXCEPT FOR THE WARRANTIES EXPRESSLY SET FORTH IN THE SELLER'S TERMS AND CONDITIONS OF SALE, SELLER MAKES NO WARRANTY EXPRESS OR IMPLIED WITH RESPECT TO THE PRODUCT, INCLUDING ANY WARRANTY OF MERCHANTABILITY OR FITNESS FOR ANY PARTICULAR PURPOSE, WHICH ARE DISCLAIMED AND EXCLUDED. All sales are subject to seller's exclusive terms and conditions of sale which, where the seller is (a) RLS merilna tehnika d.o.o., are available at <https://www.rls.si/customer-service>, (b) Renishaw, Inc., are available at <http://www.renishaw.com/Shop/legal/en/-42186>, or (c) another person, are available on request, and in each case, are incorporated herein by reference, and are the exclusive terms of sale. No other terms and conditions apply. Buyer is not authorized to make any statements or representations that expand upon or extend the environmental limitations and operating parameters of the products, or which imply permitted usage outside of that expressly stated on the datasheet or agreed to in writing by seller.

RLS merilna tehnika d.o.o. has made considerable effort to ensure the content of this document is correct at the date of publication but makes no warranties or representations regarding the content. RLS merilna tehnika d.o.o. excludes liability, howsoever arising, for any inaccuracies in this document. © 2018 RLS d.o.o.