

Orbis™

Through-hole Analogue Sin/Cos and Commutation Rotary Encoder

VARIOUS SIZES

WIDE
INSTALLATION
TOLERANCES

NON-
CONTACT

Orbis™ family is extended by analogue sin/cos, incremental and commutation through-hole encoders.

Orbis analogue provides sinusoidal outputs with a single sine/cosine period per revolution. Orbis commutation is designed for use in BLDC motor feedback applications requiring both A, B, Z incremental and U, V, W commutation signals. To simplify alignment to the motor rotor, the encoder allows setting of the zero position.

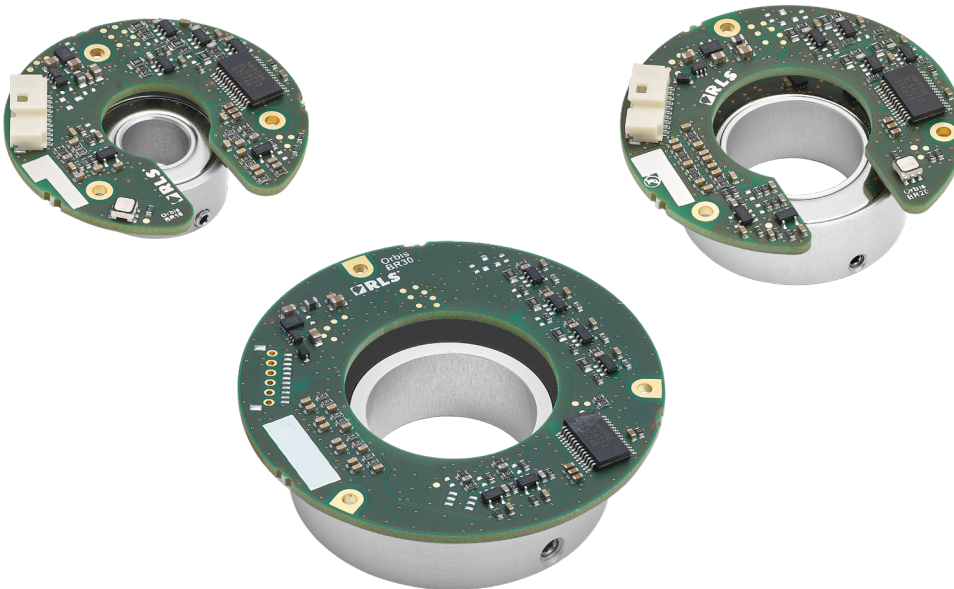

Features and benefits

- ▶ 5 V power supply
- ▶ Analogue output with one sin/cos per revolution
- ▶ Incremental with up to 4096 cpr
- ▶ UVW up to 16 poles
- ▶ Available ID: 12, 22, 30 mm
- ▶ Wide installation tolerances
- ▶ Through-hole design
- ▶ Zeroing function
- ▶ Non-contact, frictionless design



GIMBALS



AGVs



MOTOR FEEDBACK
AND COMMUTATION



PRECISE GEAR
BOX



AGRICULTURAL
AUTOMATION

General information

The encoder consists of a diametrically magnetised permanent ring magnet and a printed circuit board. The encoders are available in various designs and sizes, from 12 mm to 30 mm internal diameter. The output signals are provided in industry-standard analogue, commutation and incremental formats.

The geometrical arrangement of RLS's proprietary Hall sensors on the PCB enables the generation of one period of sine and cosine signals per revolution. Resolutions from 64 to 1024 pulses per revolution (256 to 4096 counts per revolution with ×4 evaluation) are available. U, V, W commutation signals are output simultaneously with 1 to 8 pole pairs (2 to 16 poles).

For digital absolute outputs see **BRD01** data sheet at [RLS Media Center](#).

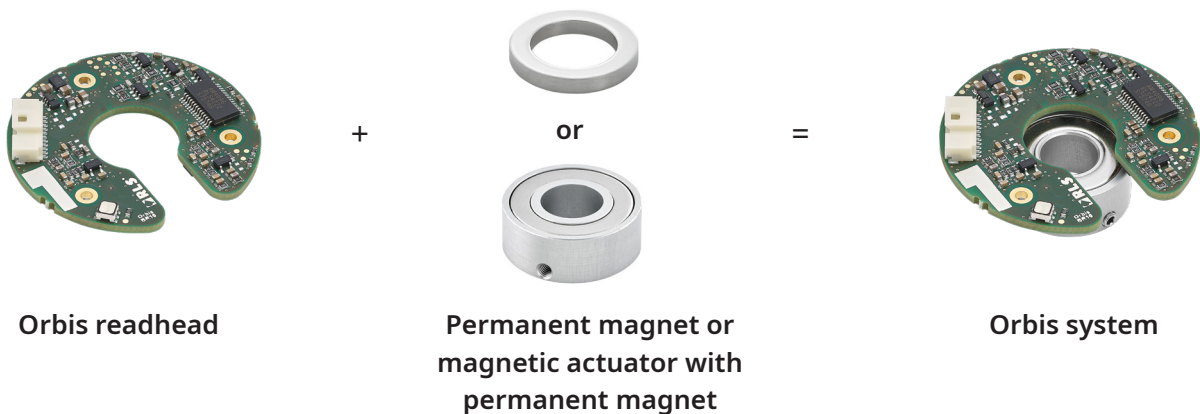

Choose your Orbis absolute magnetic encoder system

Orbis BR10 system



Max. 12 mm ID

Orbis BR20 system



Max. 22 mm ID

Orbis BR30 system



Max. 30 mm ID

Storage and handling

Storage temperature



With connector
-40 °C to +105 °C

Without connector
+15 °C to +30 °C before soldering
-40 °C to +120 °C after wires are soldered

Operating temperature



With connector
-40 °C to +105 °C

Without connector
-40 °C to +120 °C

Humidity



With connector
Up to 70% non- condensing

Without connector
Up to 10 % before soldering
Up to 70 % non-condensing, after wires are soldered

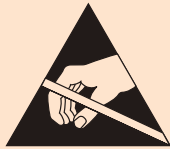

Readhead is ESD sensitive - handle with care.

Do not touch electronic circuit, wires or sensor area without proper ESD protection or outside of ESD controlled environment.

Chemical resistance

RLS products are often used in industrial applications and exposed to chemicals that can affect their internal and external components. While our products are designed to be resistant to many harsh chemicals and environments, long-term resistance will depend on exposure, temperature, and concentration. Most chemicals our products are exposed to are not in continuous contact. Therefore, a material that might not be resistant when submerged in a chemical will last indefinitely when wiped down by that same chemical once a day.

For further information or to confirm compatibility with a chemical in your environment, [contact RLS](#).

Packaging

Less than 20 products are packed individually in an antistatic box. If the order quantity is 20 systems and larger, the parts are packed in antistatic plastic trays. Magnets and readheads are packed separately.

Dimensions drawing

Dimensions and tolerances are in mm. Dimensions without tolerance values are in accordance with ISO 2768-m.



BR10 Readhead

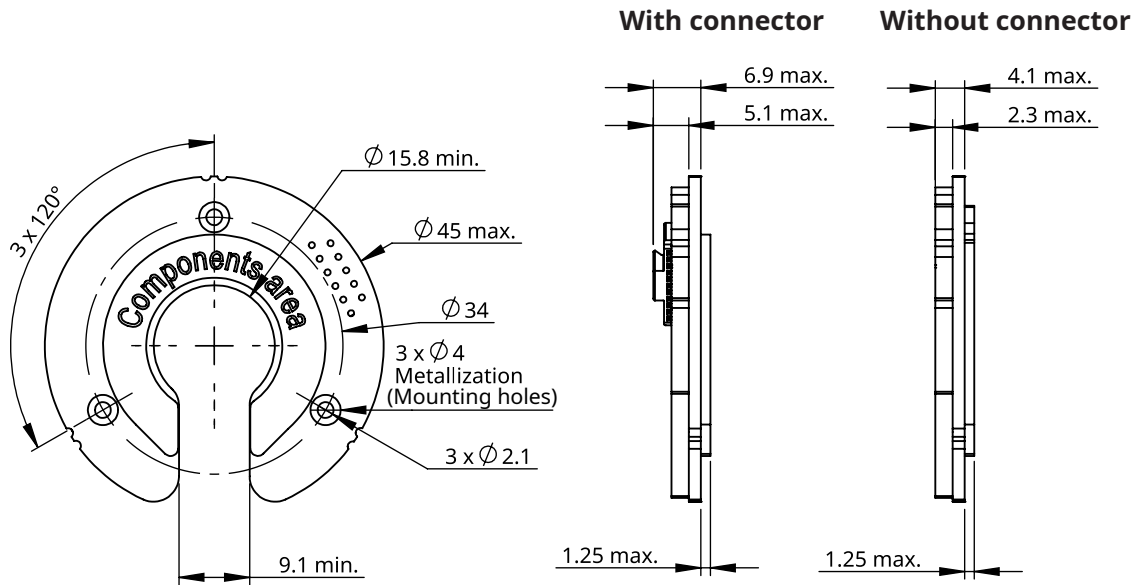

For Ux:

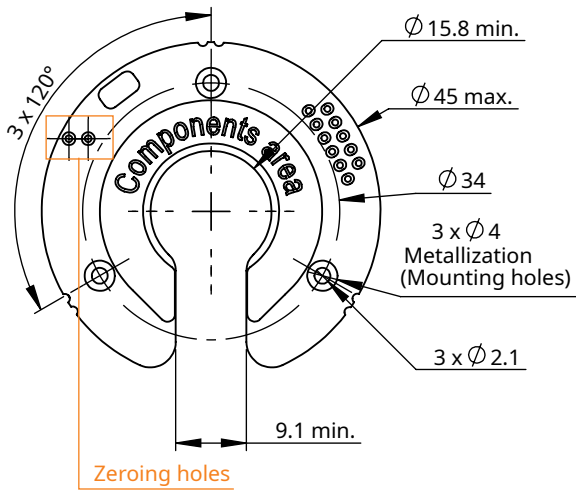

BR20 Readhead

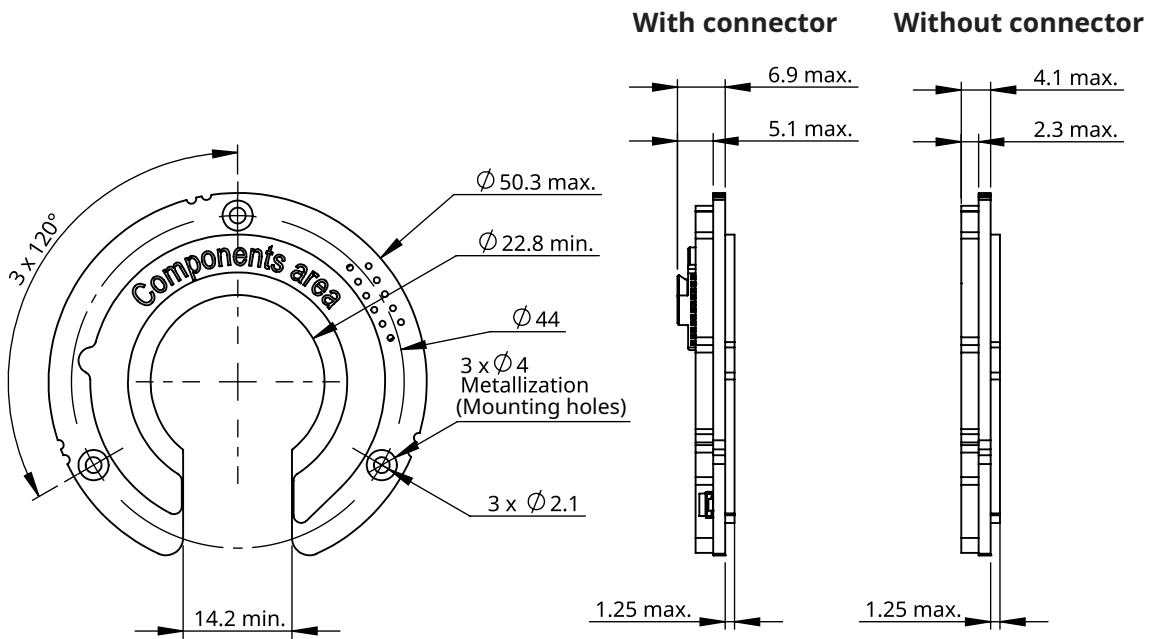

For Ux:

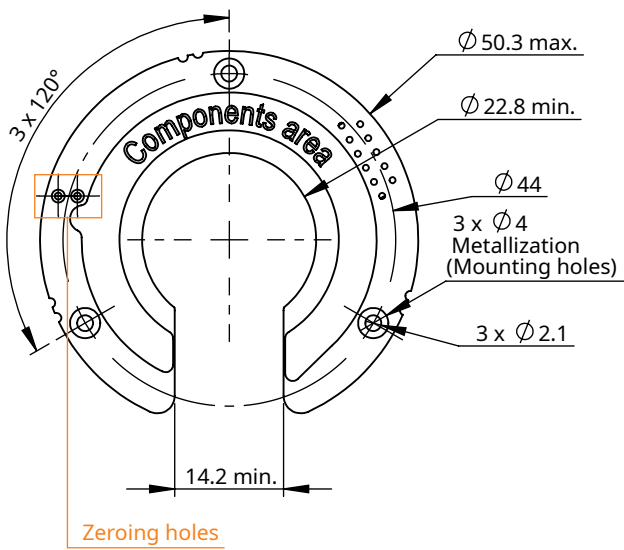

BR30 Readhead

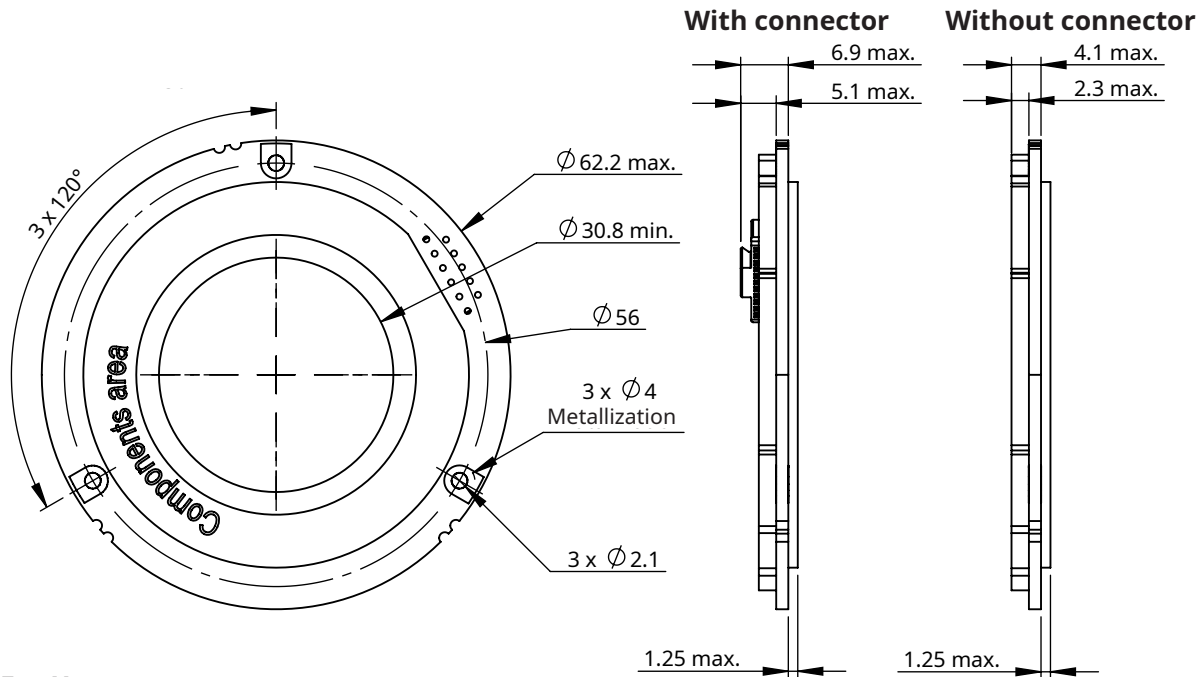

For Ux:

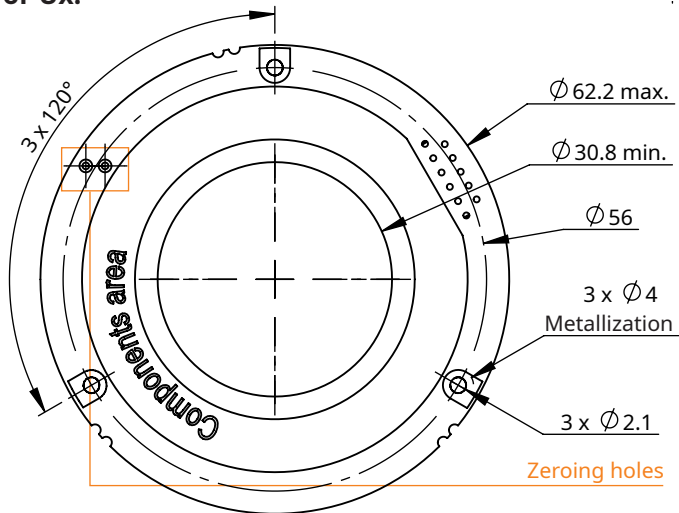

BM magnets and magnetic actuators

Permanent magnet

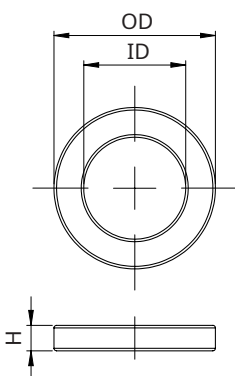

Available magnets:

ID	OD	H
12	19	3
22	32	4
30	44	4

ID, OD and H tolerances are ± 0.05 .

Magnetic actuator (magnet included)

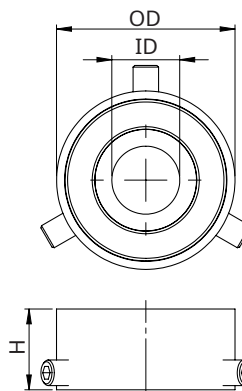

Available actuators:

ID	OD	H
6	21	9.5
8	21	9.5
10	22	9.5
20	34	12
24	47	13

ID tolerances are H7.

Installation drawing

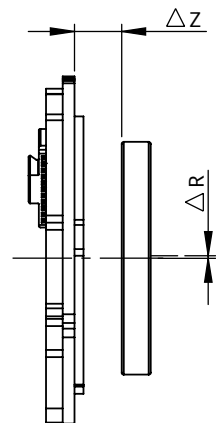
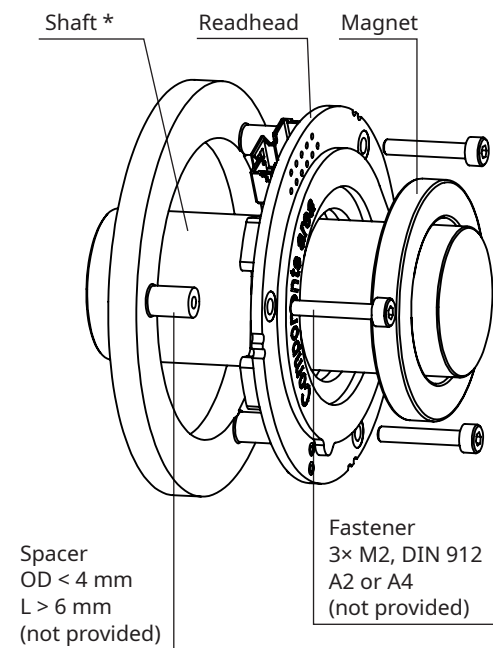
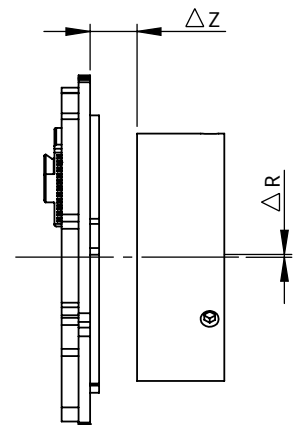
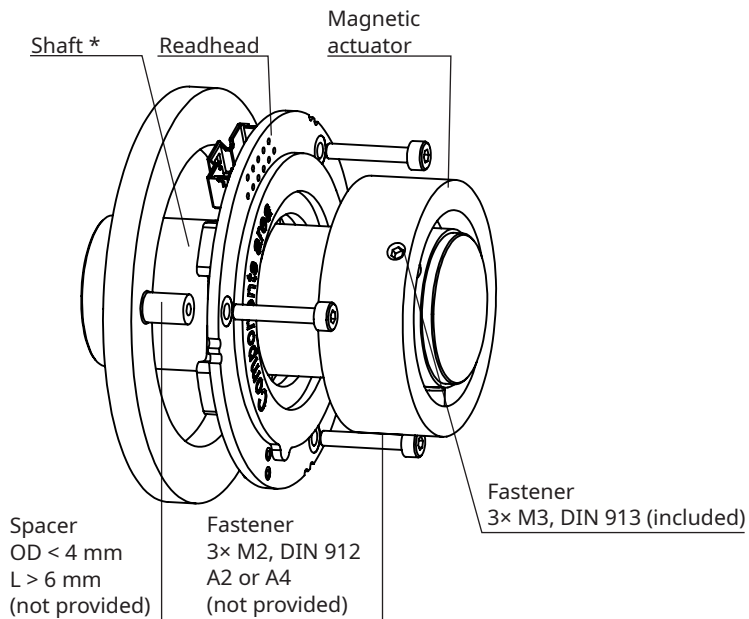

* Recommended shaft tolerance for application with magnetic actuator is g6.

Readhead should only be mounted on the gold plated surfaces around the mounting holes. See **Installation instructions**.

For recommended tightening torques, refer to the document TTD01 available at **RLS Media center**.

The specifications in this data sheet are valid when the magnet is mounted on a non-ferrous shaft. Using a ferrous shaft may affect the encoder's performance. If a ferrous shaft is used, we recommend using an actuator to prevent the magnet from being in direct contact with the ferrous material.

Installation by gluing

Application

Adhesive mounting uses materials such as industrial adhesives, epoxy resins, or adhesive tapes to join components. Before starting the assembly, always refer to the adhesive manufacturer's instructions. These include critical details such as surface preparation, application method, curing time, and environmental conditions (temperature, pressure, humidity). If no specific instructions are provided, you may follow the standard procedure below as a general guideline:

1. Clean both the shaft and the contact surfaces of the ring with alcohol. The surfaces must be clean, dry and free of dust, oil and grease.
2. Apply the Loctite EA 9514 adhesive evenly around the entire perimeter of the magnet to ensure even bonding and alignment.
3. Cure at a maximum of 130 °C for 45 minutes.

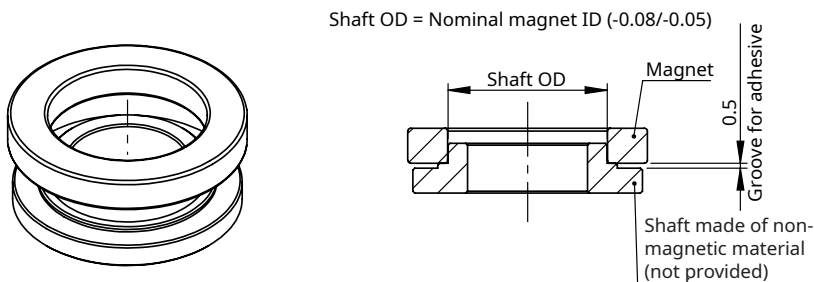

Installation instructions

Installation tolerances

Axial (ΔZ) displacement (ride height)*	Magnet with 12 mm ID	Magnet with 22 mm ID	Magnet with 30 mm ID
	4 mm \pm 1 mm	5.5 mm \pm 1 mm	4 mm \pm 1 mm

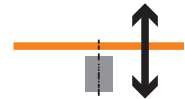

Radial (ΔR) displacement
of the sensor* Max. 0.5 mm

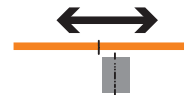

Perpendicularity
readhead 1°

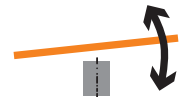

Perpendicularity
magnet 2°

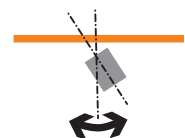

— - Readhead ■ - Magnet

Precise magnet and readhead installation is key to achieve good overall accuracy.

*See **Installation drawing**.

The specifications in this data sheet are valid when the magnet is mounted on a non-ferrous shaft. Using a ferrous shaft may affect the encoder's performance. If a ferrous shaft is used, we recommend using an actuator to prevent the magnet from being in direct contact with the ferrous material.

External magnetic field

The operating principle of any magnetic encoder is to sense changes in the magnetic field of the magnetic actuator. External magnetic fields generated by permanent magnets, electric motors, coils, magnetic brakes, etc. can affect the operation of the encoder. The accuracy of Orbis is degraded in the presence of external magnetic field. Magnetic flux density in radial direction to magnet is more critical than axial direction.

Technical specifications

System data

Reading type	Axial reading
Maximum speed	BR10, BR20: 30,000 rpm BR30: 25,000 rpm

Electrical data

Supply voltage	5 V \pm 10 %
Current consumption	Max. 35 mA
Connection	Molex 501568-1107 or soldering pads (through holes)
Short circuit protection	Yes
Reverse polarity protection	Yes
ESD protection	HBM, max. \pm 2 kV

Mechanical data



Mass	Readhead	5.3 g
	Magnetic actuator (ID)	6 mm: 6.0 g; 10 mm: 5.7 g; 8 mm: 5.5 g; 20 mm: 25 g; 24 mm: 55 g
	Magnet (ID)	12 mm: 3.8 g; 30 mm: 16.8 g; 22 mm: 12.7 g
Magnet material	12 mm, 22 mm	NdFeB with Ni-Cu-Ni protective layer
	30 mm	NdFeB + epoxy resin
Actuator material		Anodised aluminium

Environmental data

Operating and storage temperature	-40°C to +105 °C (with connector) -40°C to +120 °C (without connector)*
Humidity	0 % to 70 % non-condensing*
External magnetic field	Max. \pm 10 mT (AC) on top side of readhead. External magnetic field decreases accuracy of encoder.
Shock	100 G (6 ms, standard EN 60068-2-27:2009)
Vibration	40 G (55 Hz – 2000 Hz, standard EN 60068-2-6:2008)

* For more information see chapter [Storage and Handling](#).

Status indicator LED

LED signal	Status
 Green	Encoder is powered on.
 No light	No power supply.

If option E (-40 °C to +125 °C) is selected in [Part numbering](#), the board does **not** include a connector and LED.

Electrical connections

Pin	AC	BC	Ux
1			GND
2	Vdd		Vdd
3			Z-
4	GND		Z+
5			B+
6			B-
7	VB	VB+	A-
8		VB-	A+
9			U
10	VA	VA+	V
11		VA-	W

Pinout

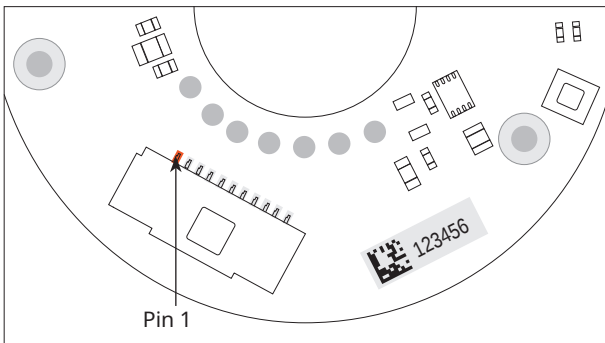

With connector Molex 501568-1107

Sizes BR10, BR20, BR30

Outputs AC, BC, Ux

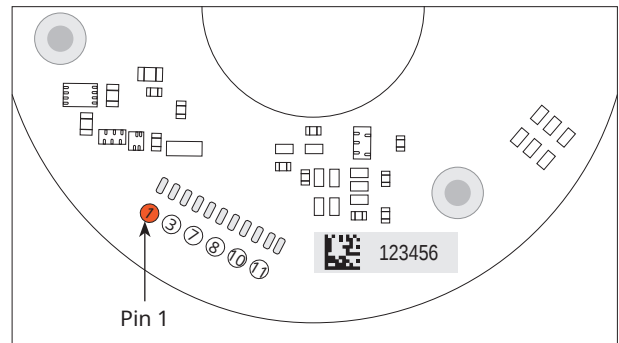

Soldering pads

Sizes BR10, BR20, BR30

Outputs AC, BC

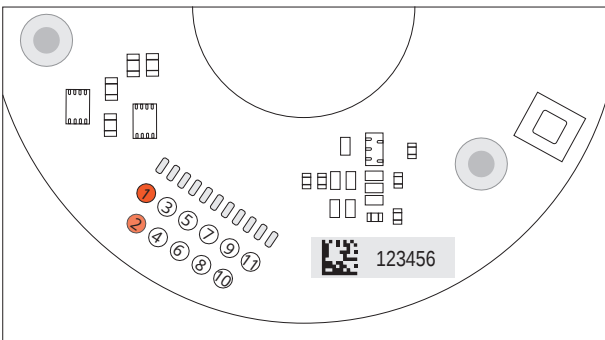

Soldering pads

Sizes BR10, BR20, BR30

Output Ux



Readhead is ESD sensitive - handle with care.

Do not touch electronic circuit, wires or sensor area without proper ESD protection or outside of ESD controlled environment.

Analogue outputs

AC - Analogue sinusoidal output

2 channels V_A and V_B sinusoids (90° phase shifted, single ended)

Power supply (V_{dd})	5 V \pm 10 %
Current consumption	Max. 35 mA
Internal serial impedance	10 Ω
Signal amplitude*	2 \pm 0.2 V_{pp}
Temperature drift	-2 mV/°C
Signal offset (V_{ref})	2.5 V \pm 1 %

*At 23 °C and 4 mm ride height (BR10, BR30)
At 23 °C and 5.5 mm ride height (BR20)

Timing diagram

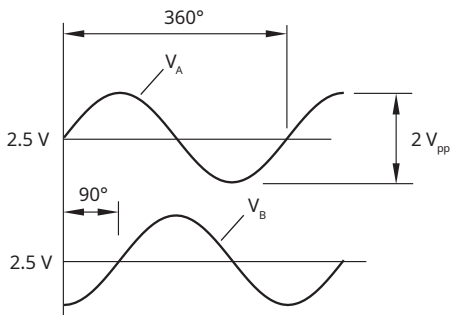

V_A leads V_B for clockwise rotation of the magnet

Grade 2 magnet must be used for AC and BC output options.

Amplitude vs. ride height

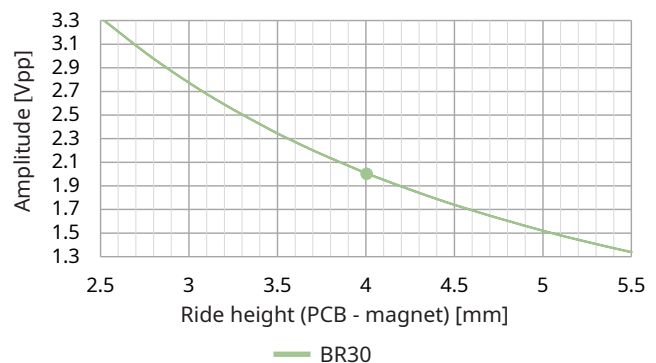
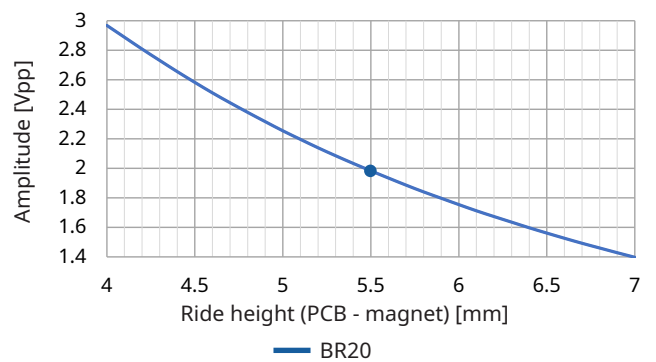
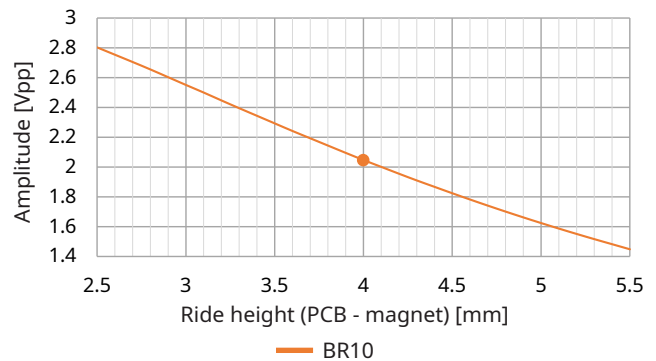

BC - Differential analogue sinusoidal output

4 channels V_{A+} , V_{A-} , V_{B+} , V_{B-} sinusoids (90° phase shifted, single ended)

Power supply (V_{dd})	5 V \pm 10 %
Current consumption	Max. 35 mA
Internal serial impedance	10 Ω
Signal amplitude*	0.5 V \pm 0.1 V (1 V_{pp})
Temperature drift	-1 mV/°C
Signal offset (V_{ref})	0 \pm 5mV

*At 23 °C and 4 mm ride height (BR10, BR30)
At 23 °C and 5.5 mm ride height (BR20)

Timing diagram

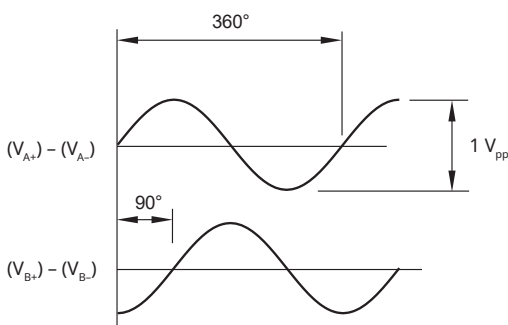

V_A leads V_B for clockwise rotation of the magnet

Grade 2 magnet must be used for AC and BC output options.

Amplitude vs. ride height

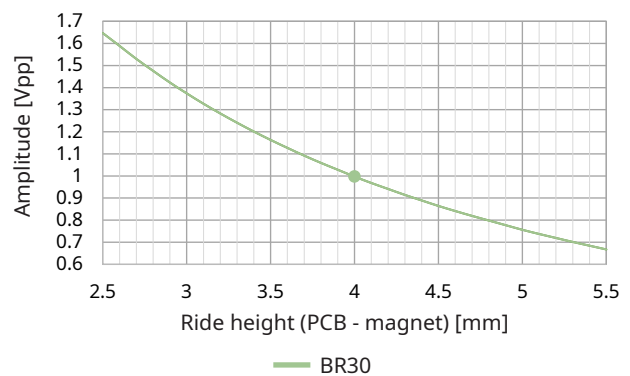
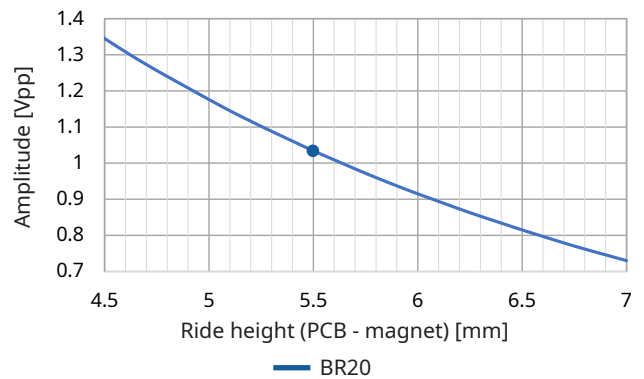
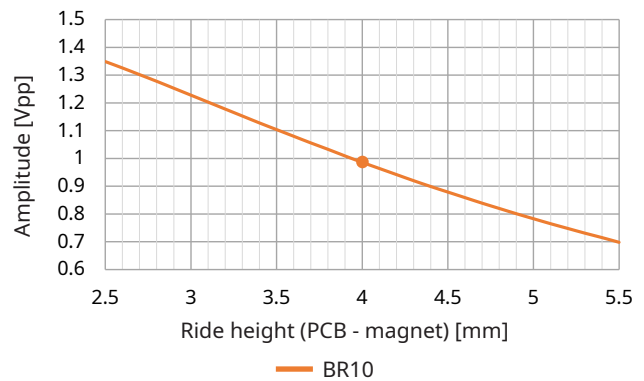

Commutation outputs

Ux - Commutation single ended + incremental with line driver

Power supply (V_{dd})	5 V \pm 10 %
Current consumption	Max. 35 mA (unloaded output)
Accuracy	\pm 0.5°
Hysteresis	0.2° typ.
Temperature drift	0.004° / C
Incremental outputs	A, B, Z, A-, B-, Z- (RS422)
Incremental resolution (cpr)	256; 512; 1,024; 2,048; 4,096
Commutation outputs	U, V, W (single ended)
Number of poles for commutation outputs	2, 4, 6, 8, 10, 12, 14, 16

Incremental outputs

There are three signals for the incremental output: A, B and Z. Signals A and B are quadrature signals, shifted by 90°, and signal Z is a reference mark. The reference mark signal is produced once per revolution. The width of the Z pulse is 1/4 of the quadrature signal period and it is synchronized with the A and B signals. The position of the reference mark is at zero. The chart below shows the timing diagram of A, B and Z signals with clockwise (CW) rotation of the magnet and positive counting direction. B leads A for CW rotation.

Timing diagram - Incremental

Complementary signals not shown.

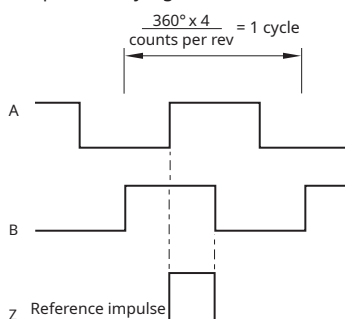

B leads A for clockwise rotation of magnet.

Commutation outputs

UVW outputs can be output as digital signals. The number of signal periods equals number of pole pairs. The timing diagram shows the signals when the position data is increasing. The U signal always starts at zero position regardless the signal period length. The resolution should be set to 4096 to ensure accurate transitions of the signals.

Timing diagram - Commutation

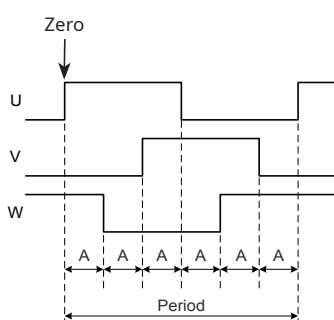

Encoder zero position can be set by shortening the zeroing holes on the board.

Recommended signal termination

For incremental outputs

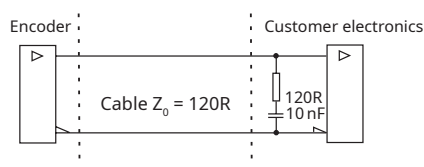

UVW outputs

Pole	A	Period	Pole pairs*
2	60°	360°	one
4	30°	180°	two
6	20°	120°	three
8	15°	90°	four
10	12°	72°	five
12	10°	60°	six
14	8.57°	51.42°	seven
16	7.50°	45°	eight

* Number of pole pairs equals number of periods per revolution.

Part numbering

Readhead

	BR	10	AC	A	01S	12	D	D	00
Series	BR - Orbis board-level readhead								
Size	10 - Magnet type compatibility 12 20 - Magnet type compatibility 22 30 - Magnet type compatibility 30								
Communication interface	AC - Absolute analogue single ended, 5 V BC - Absolute analogue differential, 5 V Ux - Commutation single ended UA - One period per revolution (2 poles) UB - Two periods per revolution (4 poles) UC - Three periods per revolution (6 poles) UD - Four periods per revolution (8 poles) UE - Five periods per revolution (10 poles) UF - Six periods per revolution (12 poles) UG - Seven periods per revolution (14 poles) UH - Eight periods per revolution (16 poles)								
Communication interface variant	A - N/A (standard)								
Resolution	01S - one sine/cosine per revolution (for AC and BC only) For Ux : 08B - 256 counts per revolution 09B - 512 counts per revolution 10B - 1,024 counts per revolution 11B - 2,048 counts per revolution 12B - 4,096 counts per revolution								
Magnet type compatibility	12 - BM120A190AxABA00 or actuator BA060-BA100 22 - BM220C320AxABA00 or actuator BA200ABxxAA00 30 - BM300C440BxBBA00 or actuator BA240ABxxAA00								
Operating temperature range	D - -40 °C to +105 °C E - -40 °C to +125 °C								
Connector option	D - Molex 501568-1107 H - Soldering pads with through holes								
Special requirements	00 - No special requirements								

Not all part number combinations are valid. Refer to the table of available combinations on the following page.

Table of available combinations

Series	Readhead size	Communication interface	Communication interface variant	Resolution	Magnet type compatibility	Operating temperature range	Connector option	Special requirements			
BR	10	AC	A	01S	12	D	D	00			
		BC				E	H				
		Ux		D		D					
	20	AC		01S		E	H				
		BC				D	D				
		Ux		E		H					
	30	AC		01S	D	D					
		BC			E	H					
		Ux		D	D						
						08B / 09B / 10B / 11B / 12B			E	H	

For digital absolute outputs see BRD01 data sheet at [RLS Media Center](#).

Magnet

BM 220 C 320 A 1 A B A 00

Series

BM - Orbis magnet

Inner diameter

120 - 12 mm

220 - 22 mm

300 - 30 mm

Thickness

A - 3 mm

C - 4 mm

Outer diameter

190 - 19 mm

320 - 32 mm

440 - 44 mm

Material

A - NdFeB

B - NdFeB + epoxy resin

Grade

1 - Grade 1 tested magnet (for Ux)

2 - Graded magnet (for AC and BC)

Surface finishing

A - NiCuNi

B - None

Temperature range

B - -40 °C to 120 °C

Packaging

A - Standard packaging

Special requirements

00 - No special requirements

Not all part number combinations are valid. Refer to the table of available combinations below.

Table of available combinations

Series	Inner diameter	Thickness	Outer diameter	Material	Grade	Surface finishing	Temperature range	Packaging	Special requirements
BM	120	A	190	A	1/2	A	B	A	00
	220	C	320						
	300	C	440	B		B			

Grade 2 magnet must be used for AC and BC output options.

Magnetic actuator

	BA	060	AB	01	A	A	00
Series	BA - Orbis magnetic actuator						
Shaft diameter	060 - 6 mm 080 - 8 mm 100 - 10 mm 200 - 20 mm 240 - 24 mm						
Form	AB - With 3 fasteners						
Magnet type	01 - BM120A190A1ABA00 (for Ux) 03 - BM220C320A1ABA00 (for Ux) 04 - BM120A190A2ABA00 (for AC and BC) 05 - BM220C320A2ABA00 (for AC and BC) 06 - BM300C440B1BBA00 (for Ux) 07 - BM300C440B2BBA00 (for AC and BC)						
Material	A - Anodized aluminium						
Packaging	A - Standard packaging						
Special requirements	00 - No special requirements						

Not all part number combinations are valid. Refer to the table of available combinations below.

Table of available combinations

Series	Shaft diameter	Form	Magnet type	Material	Packaging	Special requirements
BA	060	AB	01 / 04	A	A	00
	080					
	100		03 / 05			
	200					
	240					

Accessories

For AC and BC outputs



Cable assembly, 1 m
ACC048

See chapter **Cable assemblies**.



Cable assembly, 3 m
ACC066

See chapter **Cable assemblies**.



Cable assembly, 1 m
ACC067

See chapter **Cable assemblies**.



USB interface (incremental encoders)
E201-9Q



Magnet viewer
MM0001

For Ux output



Cable assembly, 12 core
ACC001 cable assembly 0.3 m
ACC002 cable assembly 0.5 m
ACC003 cable assembly 1 m

See chapter **Cable assemblies**.

Cable assemblies

Cables with crimped connectors

Part number	Diameter	Length	Connector 1	Connector 2	Notes
ACC001	5 mm	0.3 m	Molex 501330-1100 and 501334-0000	-	Shielded
ACC002		0.5 m			
ACC003		1.0 m			
ACC048	6.2 mm	1.0 m		Flying leads	Twisted pairs, shielded, up to +75 °C
ACC066		3.0 m			
ACC067		1.0 m		DSUB-9 M	

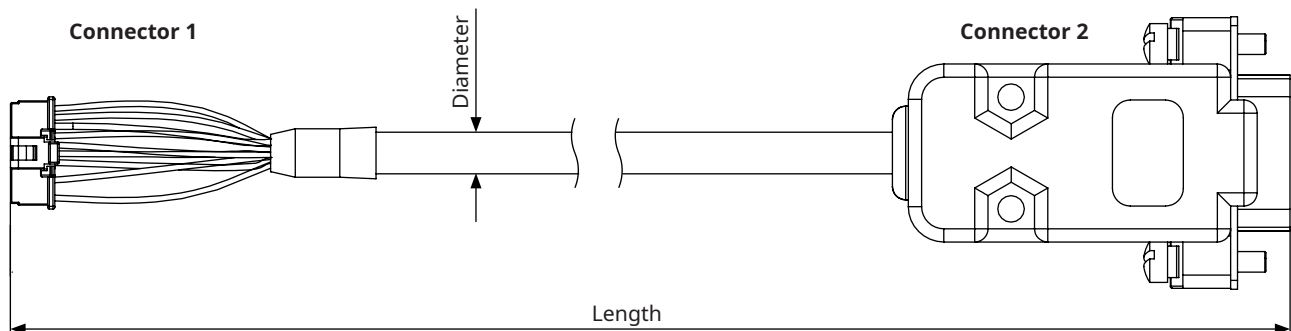

Connector 1	Connector 2	Wire color	AC	BC
Pin number				
1	5	Brown	5 V supply *	
2	-	-		
3	9	White	0 V (GND) *	
4	-	-		
5	8	Pink		-
6	4	Grey		
7	2	Red	VB	VB+
8	3	Blue	-	VB-
9	1			-
10	6	Green	VA	VA+
11	7	Yellow	-	VA-

* Pins are internally connected on PCB.

Connector 1	Wire color	Ux
Pin number		
1	Blue	GND
2	Red	Vdd
3	Brown	Z-
4	White	Z+
5	Green	B+
6	Yellow	B-
7	Grey	A-
8	Pink	A+
9	Black	U
10	Violet	V
11	Grey / Pink	W

Cable specifications

Part numbers	ACC001, ACC002, ACC003	ACC048, ACC066, ACC067
Cable specifications	LI12YC12Y	LiYCY (TP)
Configuration	12 × 0.14 mm ²	4 × 2 × 0.14 mm ²
Rated voltage	250 V	350 V
Temperature range	Operating -30 °C to +125 °C Storage -40 °C to +125 °C	Operating -40 °C to +75 °C (fixed) -5 °C to +70 °C (bending) Storage -40 °C to +80 °C
Environmental conformation	RoHS conform 73/23/EWG-Guideline CE conform Halogen free	RoHS and REACH compliant Flame-retardant according IEC 60332-1-2 Approvals based on VDE 0812 Classification ETIM 5.0 Class-ID: EC000104

ACC067 can be used for direct connection to E201-9Q encoder interface.

Head office

RLS Merilna tehnika d.o.o.

Poslovna cona Žeje pri Komendi
Pod vrbami 2
SI-1218 Komenda
Slovenia

T +386 1 5272100
E mail@rls.si
www.rls.si

Global support

Visit our [website](#) to contact your nearest sales representative.

Document issues

Issue	Date	Page	Description
01	05. 09. 2024	-	New document
02	31. 07. 2025	9	Status indicator LED added
03	15. 12. 2025	6, 9, 14, 17	Dimension of magnetic actuator changed from 25 to 24

This product is not designed or intended for use outside the environmental limitations and operating parameters expressly stated on the product's datasheet. Products are not designed or intended for use in medical, military, aerospace, automotive or oil & gas applications or any safety-critical applications where a failure of the product could cause severe environmental or property damage, personal injury or death. Any use in such applications must be specifically agreed to by seller in writing, and is subject to such additional terms as the seller may impose in its sole discretion. Use of products in such applications is at buyer's own risk, and buyer will indemnify and hold harmless seller and its affiliates against any liability, loss, damage or expense arising from such use. Information contained in this datasheet was derived from product testing under controlled laboratory conditions and data reported thereon is subject to the stated tolerances and variations, or if none are stated, then to tolerances and variations consistent with usual trade practices and testing methods. The product's performance outside of laboratory conditions, including when one or more operating parameters is at its maximum range, may not conform to the product's datasheet. Further, information in the product's datasheet does not reflect the performance of the product in any application, end-use or operating environment buyer or its customer may put the product to. Seller and its affiliates make no recommendation, warranty or representation as to the suitability of the product for buyer's application, use, end-product, process or combination with any other product or as to any results buyer or its customer might obtain in their use of the product. Buyer should use its own knowledge, judgment, expertise and testing in selecting the product for buyer's application, end-use and/or operating environment, and should not rely on any oral or written statement, representation, or samples made by seller or its affiliates for any purpose. EXCEPT FOR THE WARRANTIES EXPRESSLY SET FORTH IN THE SELLER'S TERMS AND CONDITIONS OF SALE, SELLER MAKES NO WARRANTY EXPRESS OR IMPLIED WITH RESPECT TO THE PRODUCT, INCLUDING ANY WARRANTY OF MERCHANTABILITY OR FITNESS FOR ANY PARTICULAR PURPOSE, WHICH ARE DISCLAIMED AND EXCLUDED. All sales are subject to seller's exclusive terms and conditions of sale which, where the seller is (a) RLS Merilna tehnika d. o. o., are available at <https://www.rls.si/eng/salesterms>, (b) Renishaw, Inc., are available at <https://www.renishaw.com/legal/en/-/42186>, or (c) another person, are available on request, and in each case, are incorporated herein by reference, and are the exclusive terms of sale. No other terms and conditions apply. Buyer is not authorized to make any statements or representations that expand upon or extend the environmental limitations and operating parameters of the products, or which imply permitted usage outside of that expressly stated on the datasheet or agreed to in writing by seller.

RLS Merilna tehnika d.o.o. has made considerable effort to ensure the content of this document is correct at the date of publication but makes no warranties or representations regarding the content. RLS Merilna tehnika d.o.o. excludes liability, howsoever arising, for any inaccuracies in this document. © 2025 RLS d.o.o.