

RM44 magnetic encoder base unit



The RM44 is an encoder designed for integration onto electric motors or other devices for shaft position and rotational speed measurement.

The solid metal housing helps achieve the highest IP ratings, high EMC immunity, extended operating temperature range and the best possible shock and vibration resistance.

Output signals are provided in industry standard absolute, incremental, analogue sinusoidal and linear voltage formats. Available are resolutions of up to 13 bit absolute SSI and/ or 8,192 counts per revolution incremental for 5 V or 24 V power supply.

With the provided magnet a system accuracy of $\pm 0.5^\circ$ is achievable. A range of magnetic actuators for easy integration onto

or into the shaft is also offered for easy system integration.

Product range
RM44AC

Analogue with a single sine/cosine cycle per revolution

RM44I

Incremental with 80 to 2,048 pulses per revolution (320 to 8,192 counts per revolution with x 4 evaluation) and/ or complementary analogue outputs with a single sine/cosine cycle per revolution

RM44SC

Synchro serial interface (SSI) with 320 to 8,192 positions per revolution

RM44SI

Synchro serial interface (SSI) with 320 to 8,192 positions per revolution and incremental with 80 to 2,048 pulses per revolution (320 to 8,192 counts per revolution with x 4 evaluation)

RM44Vx

Linear voltage output in a range of variants

- Easy to install – with self locating design
- Low cost for OEM integration
- Fully sealed to IP68
- High reliability from proven non-contact sensing technology
- RoHS compliant (lead free)

Storage and handling

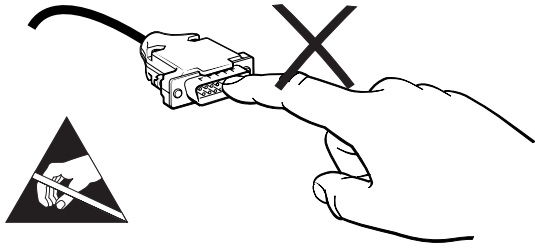

IMPORTANT: Power to RM44 encoders must be supplied from a DC SELV supply complying with the essential requirements of EN (IEC) 60950 or similar specification.

The RM44 series encoders have been designed to the relevant EMC standards, but must be correctly integrated to achieve EMC compliance. In particular, attention to shielding arrangements is critical.

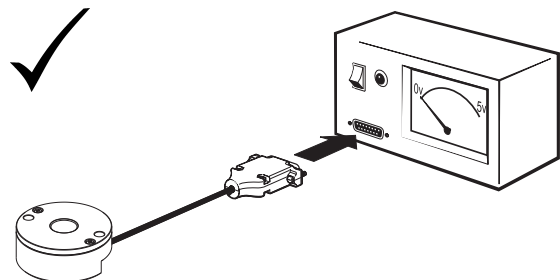
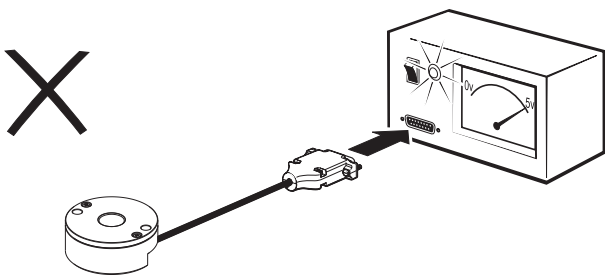

Connections

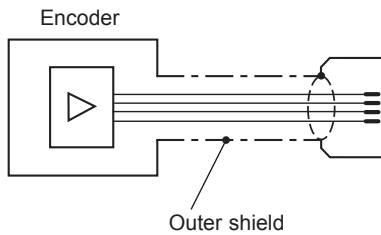

RM44AC		RM44I		RM44SC		RM44SI		RM44Vx	
Function	Wire colour	Function	Wire colour	Function	Wire colour	Function	Wire colour	Function	Wire colour
Shield - see connection diagram		Shield - see connection diagram		Shield - see connection diagram		Shield - see connection diagram			
V_{dd}	Red	V_{dd}	Red	V_{dd}	Red	V_{dd}	Red	V_{dd}	Red
GND	Orange	GND	Blue	GND	Blue	GND	Blue	GND	Orange
V_A	Black	A	Grey	A	Grey	Clock	White	V_{out}	Black
V_B	Brown	B	Green	B	Green	Data	Green		
		Z	White	Z	White	Clock-	Brown		
		A-	Pink	A-	Pink	Data-	Yellow		
		B-	Yellow	B-	Yellow				
		Z-	Brown	Z-	Brown				
				Clock	Black				
				Data	Grey/Pink				
				Clock-	Violet				
				Data-	Red/Blue				

Operating and electrical specifications

EMC compliance	EN 61326
Cable	Outside diameter 5 mm
Mass	Encoder unit 1 m cable (no connector) IP64 112 g, IP68 129 g. Magnetic actuator <2 g
Environmental sealing	IP64 (IP68 optional) EN 60529

Dimensions

Dimensions and tolerances in mm

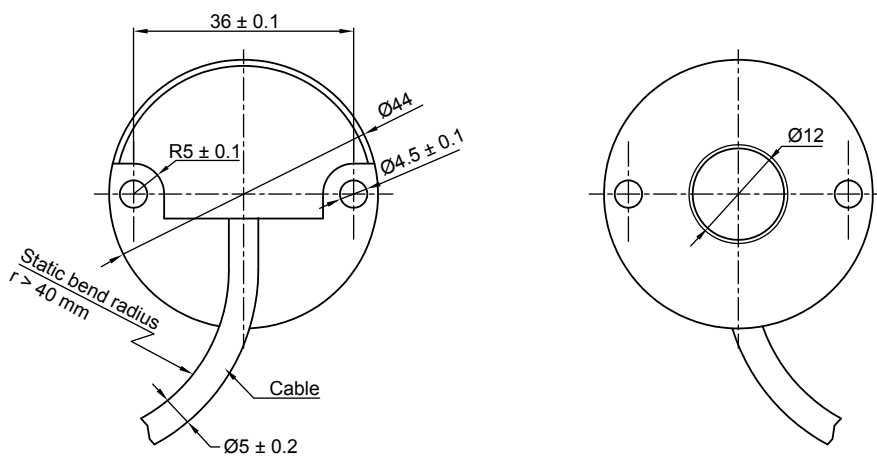
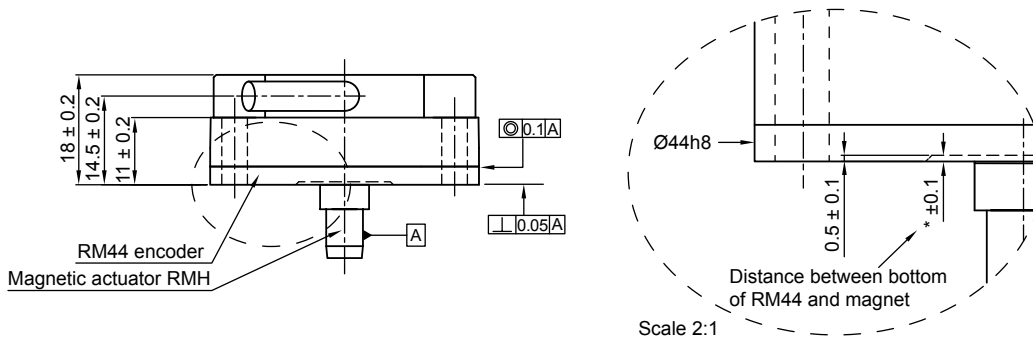

Installation drawing

Dimensions and tolerances in mm

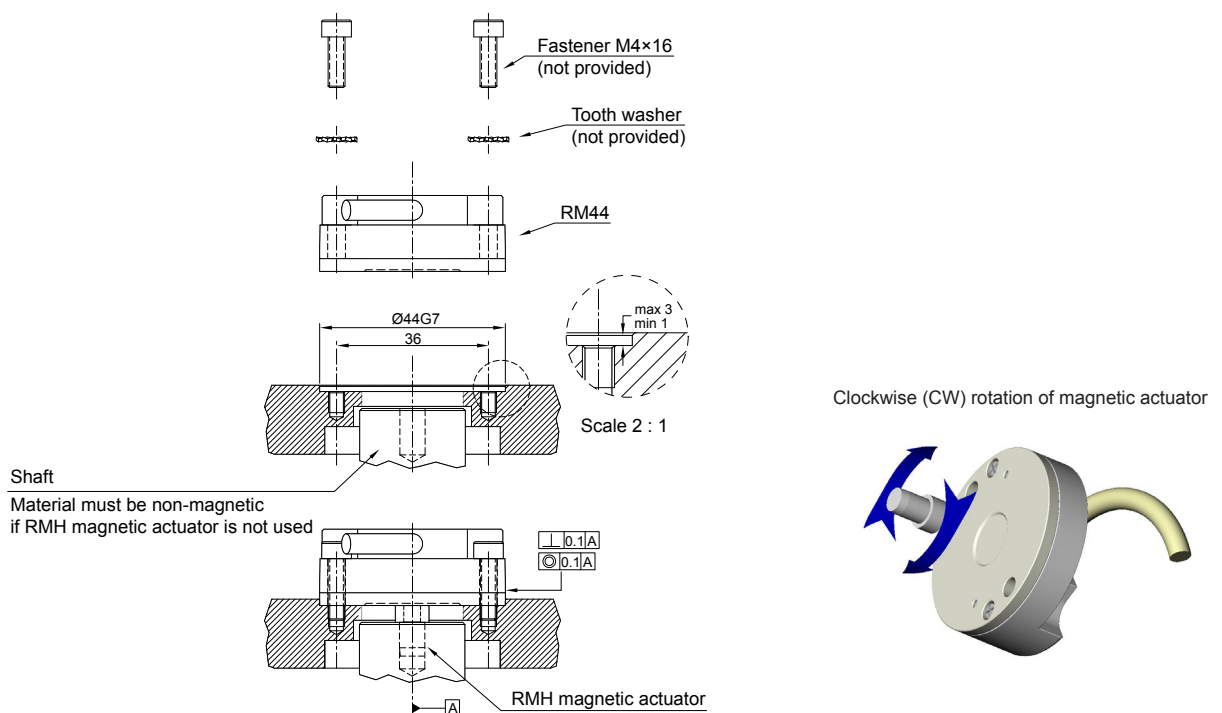

Output specifications – 5 V supply

RM44AC – Analogue sinusoidal outputs, 5 V
 2 channels V_A V_B sinusoids (90° phase shifted, single ended)

Power supply	$V_{dd} = 5\text{ V} \pm 5\%$
Power consumption	13 mA
Outputs	Signal amplitude $2 \pm 0.2\text{ V}_{pp}$ Signal offset $\frac{3}{5}V_{dd} \pm 5\text{ mV}$
Maximum output frequency	1 kHz
Maximum cable length	3 m
Operating temperature	-40 °C to +125 °C (IP64) -40 °C to +85 °C (IP68)
Maximum speed	60,000 rpm
Internal serial impedance	720 Ω

Timing diagram

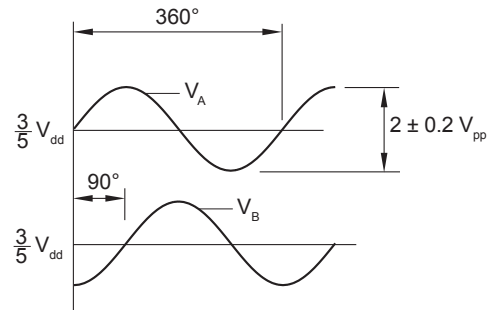

V_A leads V_B by 90° for clockwise rotation of magnetic actuator.

RM44IE – Incremental, open collector, 5 V

Low cost alternative for ball bearing encoders

Power supply	$V_{dd} = 5\text{ V} \pm 5\%$
Power consumption (not loaded)	35 mA
Maximum output load	20 mA
Output signals	A, B, Z
Maximum cable length	20 m
Operating temperature	-40 °C to +125 °C (IP64) -40 °C to +85 °C (IP68)

Resolution options (cpv)	Maximum speed (rpm)	Accuracy*	Hysteresis
128, 256	30,000	$\pm 0.7^\circ$	0.45°
320, 400, 500, 512	30,000	$\pm 0.7^\circ$	0.18°
800, 1,000, 1,024	20,000	$\pm 0.5^\circ$	0.18°
1,600, 2,000, 2,048	10,000	$\pm 0.5^\circ$	0.18°
4,096	5,000	$\pm 0.5^\circ$	0.18°
8,192	2,500	$\pm 0.5^\circ$	0.18°

* Worst case within operational parameters including magnet position and temperature.

Timing diagram

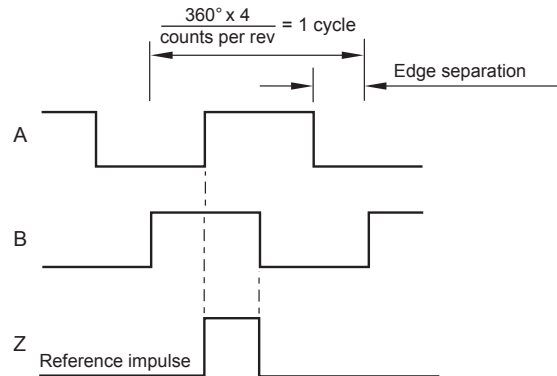

B leads A for clockwise rotation of magnetic actuator.

Recommended signal termination

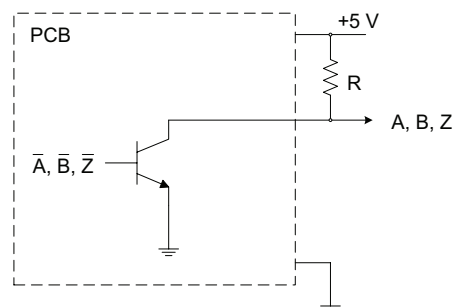

RM441C – Incremental, RS422, 5 V

Alternative for optical encoders

Power supply	$V_{dd} = 5 V \pm 5 \%$
Power consumption	13 mA for 7, 8 bit resolutions 35 mA for all other resolutions
Output signals	A, B, Z, A-, B-, Z- (RS422)
Maximum cable length	50 m
Operating temperature	-40 °C to +125 °C (IP64) -40 °C to +85 °C (IP68)

Resolution options (cpr)	Maximum speed (rpm)	Accuracy*	Hysteresis
128, 256	30,000	$\pm 0.7^\circ$	0.45°
320, 400, 500, 512	30,000	$\pm 0.7^\circ$	0.18°
800, 1,000, 1,024	20,000	$\pm 0.5^\circ$	0.18°
1,600, 2,000, 2,048	10,000	$\pm 0.5^\circ$	0.18°
4,096	5,000	$\pm 0.5^\circ$	0.18°
8,192	2,500	$\pm 0.5^\circ$	0.18°

* Worst case within operational parameters including magnet position and temperature.

Timing diagram

Complementary signals not shown

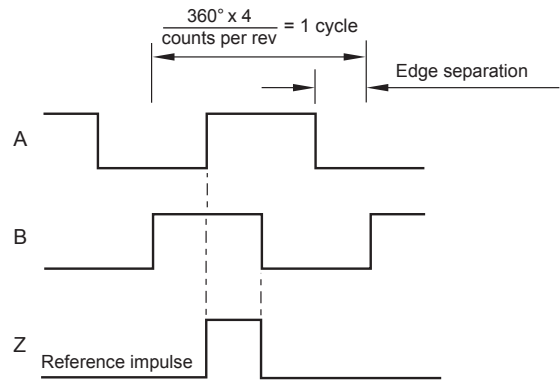

B leads A for clockwise rotation of magnetic actuator.

Recommended signal termination

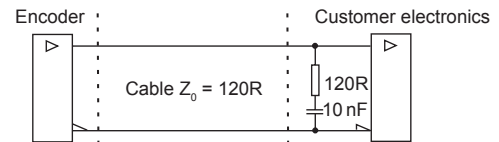

RM44SC – Absolute synchro-serial (SSI), RS422, 5 V

Alternative for optical encoders

Power supply	$V_{dd} = 5 V \pm 5 \%$
Power consumption	13 mA for 8 bit resolution 35 mA for all other resolutions
SSI output code	Natural binary
Data output	Serial data (RS422)
Data input	Clock (RS422)
Repeatability	$\leq 0.07^\circ$
Maximum cable length	100 m (at 1 MHz)
Operating temperature	-40 °C to +125 °C (IP64) -40 °C to +85 °C (IP68)

Resolution options (ppr)	Maximum speed (rpm)	Accuracy*	Hysteresis
256	30,000	$\pm 0.7^\circ$	0.45°
320, 400, 500, 512	30,000	$\pm 0.7^\circ$	0.18°
800, 1,000, 1,024	20,000	$\pm 0.5^\circ$	0.18°
1,600, 2,000, 2,048	10,000	$\pm 0.5^\circ$	0.18°
4,096	5,000	$\pm 0.5^\circ$	0.18°
8,192	2,500	$\pm 0.5^\circ$	0.18°

* Worst case within operational parameters including magnet position and temperature.

Timing diagram

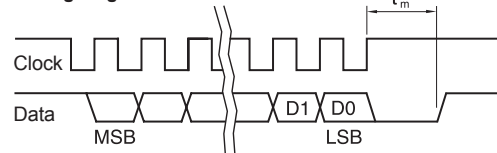

Clock ≤ 1 MHz $16 \mu s \leq t_m \leq 22 \mu s$ (for 8 bit resolution)
Clock ≤ 4 MHz $12.5 \mu s \leq t_m \leq 20.5 \mu s$ (for all other resolutions)

Position increases for clockwise rotation of magnetic actuator.

Recommended signal termination

For data output lines only

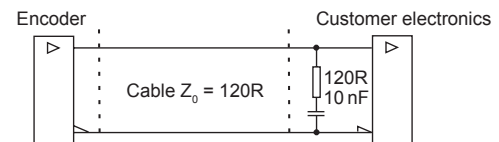

RM44SI – Absolute binary synchro-serial (SSI) + Incremental, RS422, 5 V

Complex feedback device for absolute position at start up as well as during operation + incremental outputs.

Both the incremental and the SSI output always have the same fixed resolution.

Power supply	$V_{dd} = 5 V \pm 5 \%$
Power consumption	35 mA
SSI output code	Natural binary
Data output	Serial data (RS422)
Data input	Clock (RS422)
Incremental outputs	A, B, Z, A-, B-, Z- (RS422)
Maximum cable length	50 m
Operating temperature	-40 °C to +125 °C (IP64) -40 °C to +85 °C (IP68)

Resolution options (ppr/cpr)	Maximum speed (rpm)	Accuracy*	Hysteresis
320, 400, 500, 512	30,000	±0.7°	0.18°
800, 1,000, 1,024	20,000	±0.5°	0.18°
1,600, 2,000, 2,048	10,000	±0.5°	0.18°
4,096	5,000	±0.5°	0.18°
8,192	2,500	±0.5°	0.18°

* Worst case within operational parameters including magnet position and temperature.

Timing diagram - SSI

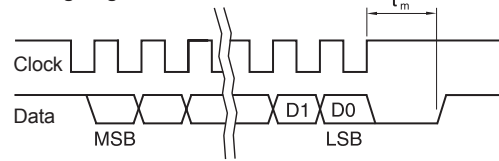

Clock ≤ 4 MHz $12.5 \mu s \leq t_m \leq 20.5 \mu s$

Position increases for clockwise rotation of magnetic actuator.

Timing diagram - Incremental

Complementary signals not shown

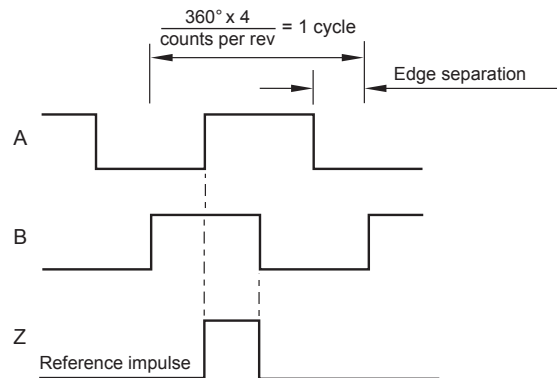

B leads A for clockwise rotation of magnetic actuator.

Recommended signal termination

For incremental signals + SSI data output lines only

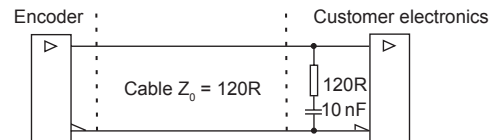

RM44Vx – Linear voltage output, 5 V

Alternative for potentiometers

Power supply	$V_{dd} = 5\text{ V} \pm 5\%$
Power consumption	26 mA (not loaded)
Output voltage	0 V to V_{dd}
Output loading	Max. 10 mA
Nonlinearity	1 %
Maximum cable length	20 m
Operating temperature	-40 °C to +125 °C (IP64) -40 °C to +85 °C (IP68)
Maximum speed	30,000 rpm

Φ_{period}	N_{period}	N_{step}	Φ_{step}
360°	1	1,024	0.35°
180°	2	1,024	0.18°
90°	4	1,024	0.09°
45°	8	512	0.09°

Output type and electrical variant

Φ_{period}	360°	180°	90°	45°
Rotation				
Clockwise	VA	VB	VC	VD
Counterclockwise	VE	VF	VG	VH

Timing diagram

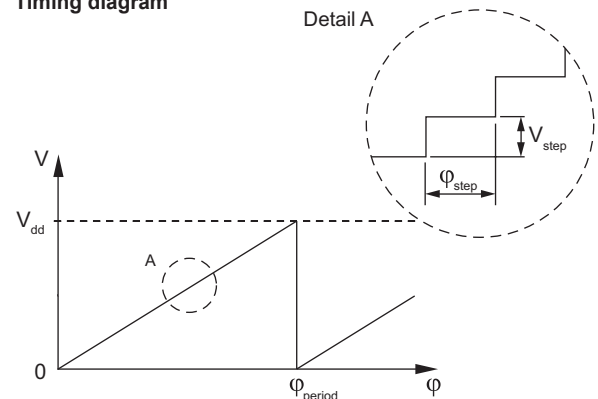

$$\Phi_{\text{step}} = \frac{\Phi_{\text{period}}}{N_{\text{step}}} \quad V_{\text{step}} = \frac{V_{dd}}{N_{\text{step}}}$$

- Φ_{period} = Angle covered in one period (one sawtooth)
- V_{period} = Output voltage range for one period
- Φ_{step} = Step angle (angular movement needed to register a change in the position)
- V_{step} = Output voltage range for one step
- N_{period} = Number of periods in one revolution
- N_{step} = Number of steps in one period

Output specifications – 24 V supply

RM44IA – Incremental, push-pull, 24 V

Power supply	$V_{dd} = 8\text{ V to }26\text{ V}$
Power consumption	50 mA (at 24 V)
Maximum output load	30 mA
Output signals	A, B, Z, A-, B-, Z- (RS422)
Maximum cable length	20 m
Operating temperature	-40 °C to +125 °C (IP64) -40 °C to +85 °C (IP68)

Resolution options (cpr)	Maximum speed (rpm)	Accuracy*	Hysteresis
320, 400, 500, 512	30,000	$\pm 0.7^\circ$	0.18°
800, 1,000, 1,024	20,000	$\pm 0.5^\circ$	0.18°
1,600, 2,000, 2,048	10,000	$\pm 0.5^\circ$	0.18°
4,096	5,000	$\pm 0.5^\circ$	0.18°
8,192	2,500	$\pm 0.5^\circ$	0.18°

* Worst case within operational parameters including magnet position and temperature.

Timing diagram

Complementary signals not shown

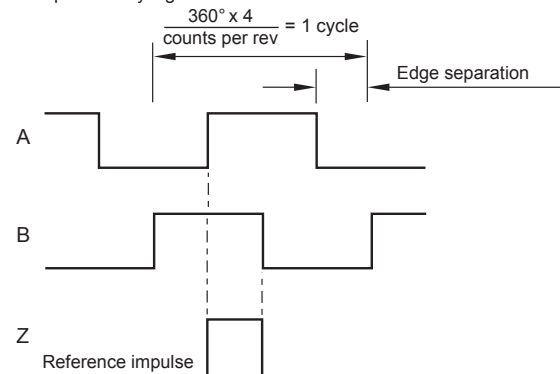

B leads A for clockwise rotation of magnetic actuator.

Data sheet
RM44D01_06

RM44IB – Incremental, open collector NPN, 24 V
 Square wave output

Power supply	$V_{dd} = 8\text{ V to }26\text{ V}$
Power consumption	50 mA (at 24 V)
Maximum output load	20 mA
Output signals	A, B, Z
Maximum cable length	20 m
Operating temperature	-40 °C to +125 °C (IP64) -40 °C to +85 °C (IP68)

Resolution options (cpr)	Maximum speed (rpm)	Accuracy	Hysteresis
128, 256	30,000	±0.7°	0.45°
320, 400, 500, 512	30,000	±0.7°	0.18°
800, 1,000, 1,024	20,000	±0.5°	0.18°
1,600, 2,000, 2,048	10,000	±0.5°	0.18°
4,096	5,000	±0.5°	0.18°
8,192	2,500	±0.5°	0.18°

Worst case within operational parameters including magnet position and temperature.

Timing diagram

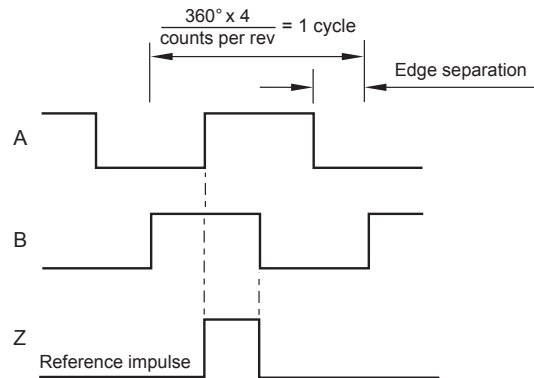

B leads A for clockwise rotation of magnetic actuator.

RM44IG – Incremental, RS422 (5 V), 24 V power supply

Power supply	$V_{dd} = 8\text{ V to }26\text{ V}$
Power consumption (at 24 V)	50 mA
Max. output load	20 mA
Output signals	A, B, Z, A-, B-, Z-
Max. cable length	20 m (5 V)
Operating temperature	-40 °C to +125 °C (IP64) -40 °C to +85 °C (IP68)

Resolution options (cpr)	Maximum speed (rpm)	Accuracy	Hysteresis
128, 256	30,000	±0.7°	0.45°
320, 400, 500, 512	30,000	±0.7°	0.18°
800, 1,000, 1,024	20,000	±0.5°	0.18°
1,600, 2,000, 2,048	10,000	±0.5°	0.18°
4,096	5,000	±0.5°	0.18°
8,192	2,500	±0.5°	0.18°

Worst case within operational parameters including magnet position and temperature.

Timing diagram

Complementary signals not shown

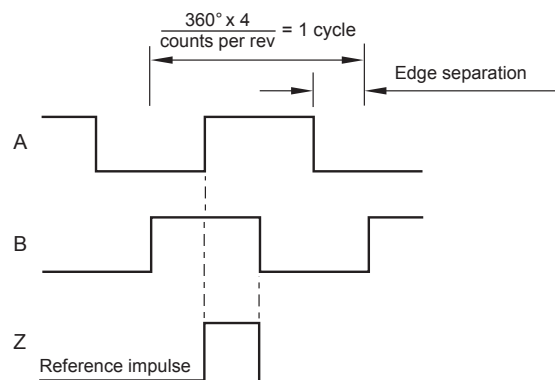

B leads A for clockwise rotation of magnetic actuator.

Ordering code

Encoder system = Encoder body + Magnetic actuator or flange

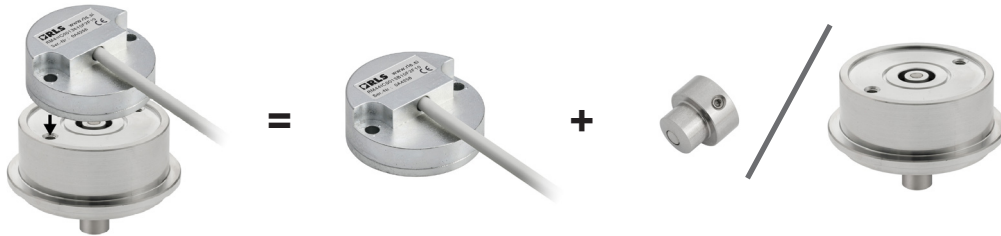

RM44 encoder-sensor unit
eg. **RM44IC0013B10F2E10**

Magnetic actuator
eg **RMA06A3A00**

Flange
eg **RE58A10**

RM44 IC 00 13B 10 F 2 E 10

Output type

- AC - Analogue sinusoidal, 5 V
- IA - Incremental, push pull, 24 V
- IB - Incremental, open collector NPN, 24 V
- IC - Incremental, RS422, 5 V
- IE - Incremental, open collector, 5 V
- IG - Incremental, RS422, 5 V, supply 24 V
- SC - Absolute binary synchro-serial (SSI), RS422, 5 V
- SI - SSI + Incremental, RS422, 5 V
- Vx - Linear voltage:

Linear voltage output 0 - 5 V, supply 5 V DC				
	360°	180°	90°	45°
Clockwise	VA	VB	VC	VD
Counterclockwise	VE	VF	VG	VH

Shaft size

00 - n/a

Resolution

- For AC:
01S - One sine/cosine period per revolution
- For Vx:
10B - 1024 counts or positions per revolution

For output types IA, IB, IC, IE, IG, SC and SI:

Decimal			Binary		
D32 - 320	D80 - 800	2D0 - 2000	07B - 128	10B - 1024	13B - 8192
D40 - 400	1D0 - 1000		08B - 256	11B - 2048	
D50 - 500	1D6 - 1600		09B - 512	12B - 4096	

Special requirements

- 10 - No special requirements (standard)
- 1M - Cable length in meters

Environment and material

- E - IP64, standard EMC grade, Zinc alloy (standard)
- F - IP68, standard EMC grade, Zinc alloy

Body style and cable exit

- 2 - Cylindrical body, radial cable exit

Connector options

- F - Flying lead (no connector)

Cable length

- 10 - 1.0 meter (or 10 meters if 1M special requirement is chosen)

NOTE: Not all combinations are valid.

Magnetic actuators and magnets

Actuator for integration onto shaft

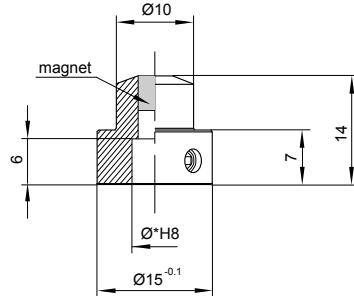

Shaft = Ø*h7
Fixing: Grub screw provided

Part numbers:

For resolutions up to 9 bit absolute (512 cpr incremental)
RMA04A2A00 – Ø4 mm shaft **RMA10A2A00** – Ø10 mm shaft
RMA05A2A00 – Ø5 mm shaft **RMA19A2A00** – Ø3/16" shaft
RMA06A2A00 – Ø6 mm shaft **RMA25A2A00** – Ø1/4" shaft
RMA08A2A00 – Ø8 mm shaft **RMA37A2A00** – Ø3/8" shaft

For resolutions from 10 bit absolute (800 cpr incremental) and above
RMA04A3A00 – Ø4 mm shaft **RMA10A3A00** – Ø10 mm shaft
RMA05A3A00 – Ø5 mm shaft **RMA19A3A00** – Ø3/16" shaft
RMA06A3A00 – Ø6 mm shaft **RMA25A3A00** – Ø1/4" shaft
RMA08A3A00 – Ø8 mm shaft **RMA37A3A00** – Ø3/8" shaft

Actuator for integration into shaft

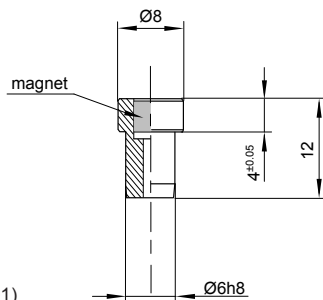

Hole = Ø6G7
Fixing: Glue (recommended – LOCTITE 648 or LOCTITE 2701)

Part numbers:

For resolutions up to 9 bit absolute (512 cpr incremental)
RMH06A2A00

For resolutions from 10 bit absolute (800 cpr incremental) and above
RMH06A3A00

Magnet for direct recessing in non-ferrous shafts

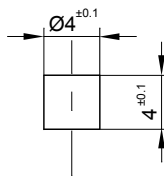

Fixing: Glue (recommended – LOCTITE 648 or LOCTITE 2701)

Part numbers:

For resolutions up to 9 bit absolute (512 cpr incremental)
RMM44A2A00 (individually packed) – for sample quantities only
RMM44A2C00 (packed in tubes)

For resolutions from 10 bit absolute (800 cpr incremental) and above
RMM44A3A00 (individually packed) – for sample quantities only
RMM44A3C00 (packed in tubes)

RE58 flange part numbering

Refer to RE58 datasheet for further details.



Part numbers:

RE58A10 - Ø58 mm 10 mm shaft

RE58B06 - Ø58 mm 6 mm shaft

RE58C10 - Ø58 mm 10 mm shaft

All RE58 flanges are supplied with required washer and M4 fasteners for RM44 encoder attachment.

Head office

RLS merilna tehnika d.o.o.

Poslovna cona Žeje pri Komendi
Pod vrbami 2
SI-1218 Komenda
Slovenia

T +386 1 5272100

F +386 1 5272129

E mail@rls.si

www.rls.si

Document issues

Issue	Date	Page	Amendments done
02	26. 2. 2008	-	New layout with new images, outputs V and IB , SSI clock, vibration shock test
03	14. 1. 2009	-	New layout
04	24. 11. 2010	-	New magnet dimensions and RE58 flange images, extended operating temperature range description and RM44AC timing diagram changed
05	14. 8. 2015	2	Storage and handling added
		3	Installation drawing tolerance amended
		4-9	New resolution options added to outputs IB and IE , IG output added, option 18 removed
		10	Loctite information updated
06	2. 11. 2015	3	Dimension picture updated