

## RMB20 encoder module with AM4096

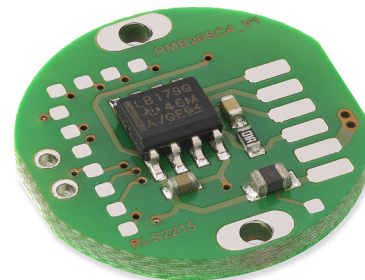
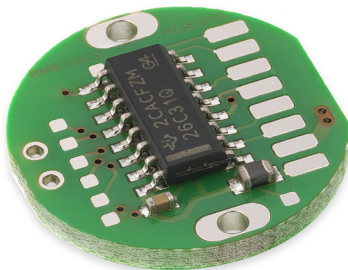

The RMB20 encoder module provides the functionality of the RM22 encoder in a compact component format for simple customer integration. With a PCB diameter of only 20 mm the module fits into miniature designs.

The encoder modules consist of a magnetic actuator and a separate sensor board. Rotation of the magnetic actuator is sensed by a custom encoder chip mounted on the sensor board, and processed to give the required output format. Output signals are provided in industry standard absolute, incremental, analogue, commutation and linear formats.

The RMB20 can be designed into equipment used in a wide range of applications including marine, medical, print, converting, industrial automation, motor control and instrumentation.

### Product range

#### RMB20IC

Incremental with 8 to 1024 pulses per revolution (32 to 4096 counts per revolution with x4 evaluation).

#### RMB20SC

Synchro serial interface (SSI) with 32 to 4096 positions per revolution.

The encoder module includes zeroing pads for setting the encoder zero position. The new zero position can be set by shorting the two zeroing pads.

- Price performance solution
- 20 mm diameter circular module
- 5 V power supply
- High speed operation to 60,000 rpm
- Absolute - up to 12 bit resolution
- Industry standard absolute and incremental output formats
- Accuracy to  $\pm 0.5^\circ$
- RoHS compliant (lead free) - see Declaration of conformity



Installation drawing

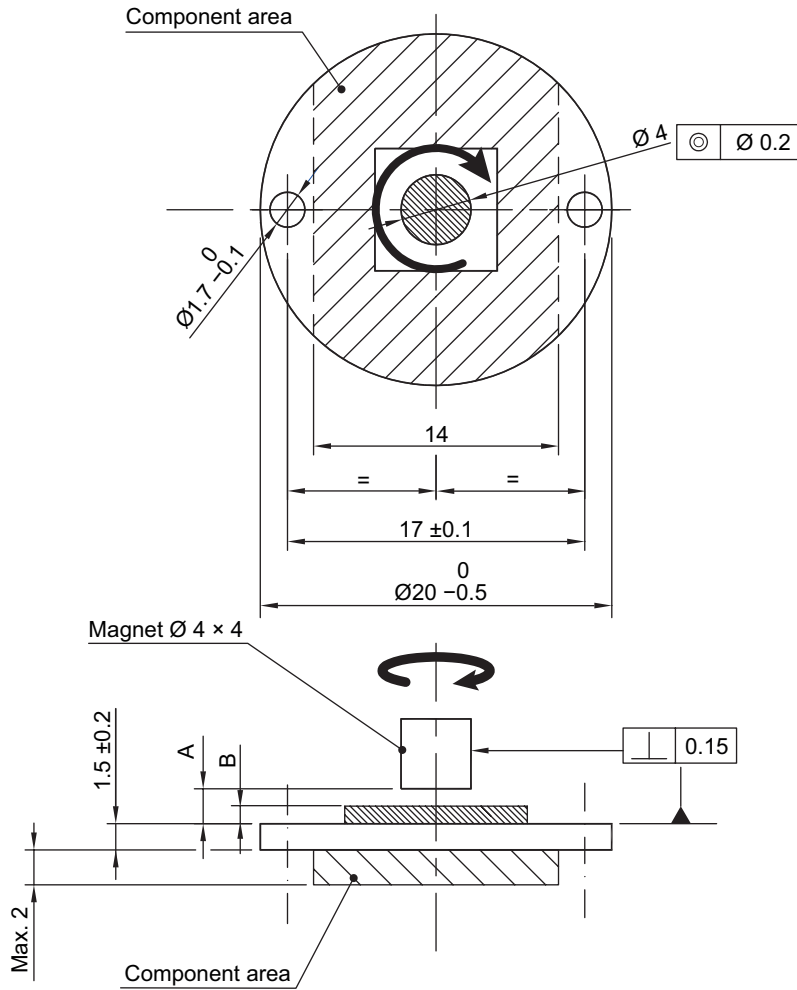

Module	A PCB surface to magnet distance [mm]	B Chip height [mm]
RMB20IC	2.8 ± 0.5	Max. 1.60
RMB20SC		

**NOTE:** For the accuracy specified the center line of the magnet needs to be square to the chip within 2° and aligned within the center of the board ±0.1 mm (mid point between the 2 mounting holes).

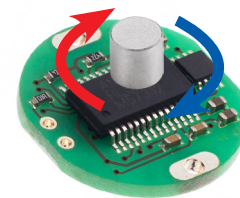

Clockwise (CW) rotation of magnet

## RMB20IC – Incremental output

Square wave differential line driver to RS422

<b>Power supply</b>	$V_{dd} = 5\text{ V} \pm 5\%$
<b>Power consumption</b>	35 mA
<b>Output signals</b>	A, B, Z, A-, B-, Z- (RS422)
<b>Resolutions</b>	32, 64, 128, 256, 512, 1,024, 2,048, 4,096 cpr
<b>Maximum speed</b>	60.000 for resolutions up to 1,024 cpr 30.000 for 2,048 and 4,096 cpr
<b>Accuracy</b>	$\pm 0.5^\circ$
<b>Hysteresis</b>	$0.18^\circ$
<b>Temperature</b>	$-40\text{ }^\circ\text{C}$ to $+125\text{ }^\circ\text{C}$
Operating and storage	

### Connections

RMB20IC

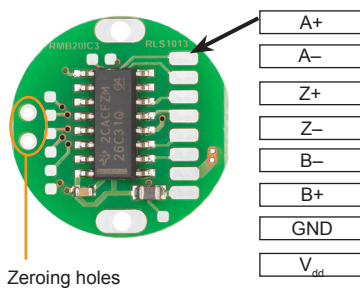

### Timing diagram

Complementary signals not shown

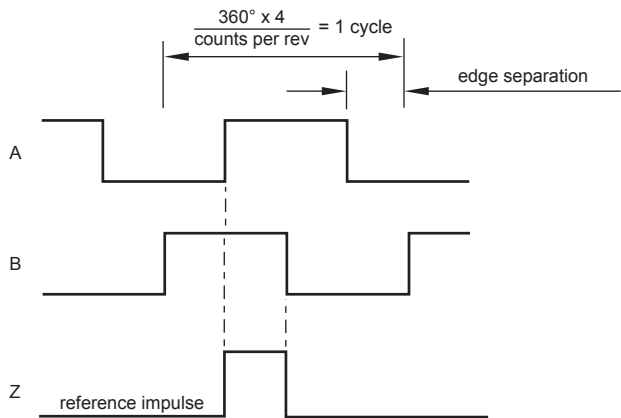

B leads A for clockwise rotation of magnet.

### Recommended signal termination

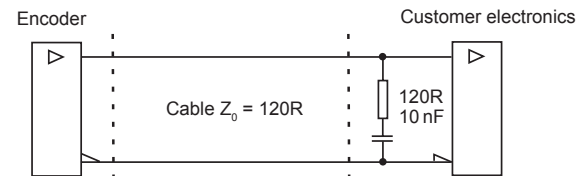

## RMB20SC – Absolute binary synchro-serial interface (SSI)

Serial encoded absolute position measurement

<b>Output code</b>	Natural binary
<b>Power supply</b>	$V_{dd} = 5\text{ V} \pm 5\%$
<b>Power consumption</b>	35 mA
<b>Resolutions</b>	512, 1,024, 2,048, 4,096 positions per revolution
<b>Repeatability</b>	$\leq 0.07^\circ$
<b>Data output</b>	Serial data (RS422)
<b>Data input</b>	Clock (RS422)
<b>Temperature</b>	$-40\text{ }^\circ\text{C}$ to $+125\text{ }^\circ\text{C}$
Operating and storage	

### Connections

RMB20SC

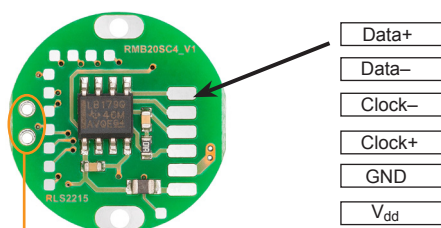

### Timing diagram

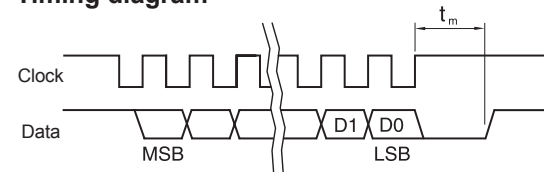

Clock  $\leq 4\text{ MHz}$      $12.5\text{ }\mu\text{s} \leq t_m \leq 20.5\text{ }\mu\text{s}$

Position increases for clockwise rotation of magnet.

### Recommended signal termination

For data output lines only

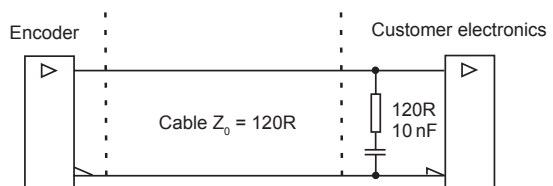

### Zero position setting procedure

The output angle position data can be zeroed at any angle with resolution of 0.0879°. The relative output position is the difference between absolute position and data in the zero register.

The value in the zero register can be changed by writing a desired value with the TWI interface or with using a “Zero” input pin. With low to high transition of a signal on “Zero” pin the current absolute value is stored into the zero register. When zeroing the relative position, the chip must not be in power-save mode as the EEPROM is not accessible in this state.

#### RMB20 zeroing example

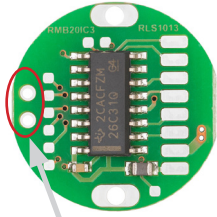

zeroing holes

The zeroing holes can be shorted to set the zero position of the encoder.

### Ordering code

**RMB20 IC 09B C 96**

**Output type**

IC - Incremental, RS422  
SC - Absolute binary synchro-serial (SSI), RS422

**Resolution**

Counts/positions per revolution:

<b>05B</b> - 32	<b>08B</b> - 256	<b>11B</b> - 2048
<b>06B</b> - 64	<b>09B</b> - 512	<b>12B</b> - 4096
<b>07B</b> - 128	<b>10B</b> - 1024	

**Special requirements\***  
96 - With AM4096 - up to 12 bit

**Shape**  
C - Circular

\* For sample quantities of RMB20 supplied with a magnet please add “KIT” to the end of the required RMB20 part number, eg. RMB20IC09BC96KIT.

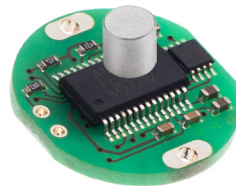

## Magnetic actuator and magnet ordering information

### Actuator for integration onto shaft

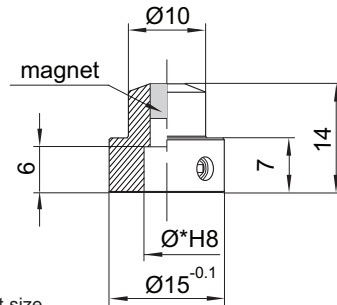

Shaft = Ø\*h7

Fixing: Grub screw provided

\* Hole diameter for nominal shaft size.  
See table on the right for more information on available shaft sizes.

#### Part numbers:

For resolutions up to 9 bit absolute (512 cpr incremental)

**RMA04A2A00** – Ø4 mm shaft      **RMA10A2A00** – Ø10 mm shaft

**RMA05A2A00** – Ø5 mm shaft      **RMA19A2A00** – Ø3/16" shaft

**RMA06A2A00** – Ø6 mm shaft      **RMA25A2A00** – Ø1/4" shaft

**RMA08A2A00** – Ø8 mm shaft      **RMA37A2A00** – Ø3/8" shaft

For resolutions from 10 bit absolute (800 cpr incremental) and above

**RMA04A3A00** – Ø4 mm shaft      **RMA10A3A00** – Ø10 mm shaft

**RMA05A3A00** – Ø5 mm shaft      **RMA19A3A00** – Ø3/16" shaft

**RMA06A3A00** – Ø6 mm shaft      **RMA25A3A00** – Ø1/4" shaft

**RMA08A3A00** – Ø8 mm shaft      **RMA37A3A00** – Ø3/8" shaft

### Actuator for integration into shaft

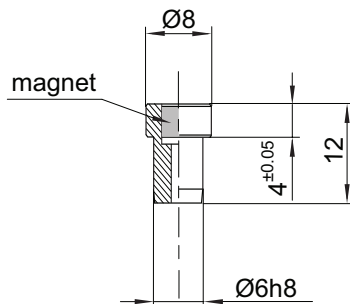

#### Part numbers:

For resolutions up to 9 bit absolute (512 cpr incremental)

**RMH06A2A00**

For resolutions from 10 bit absolute (800 cpr incremental) and above

**RMH06A3A00**

#### With N-pole marker scribed to a ±5° accuracy:

For resolutions up to 9 bit absolute (512 cpr incremental)

**RMH06A2A02**

For resolutions from 10 bit absolute (800 cpr incremental) and above

**RMH06A3A02**

Hole = Ø6G7

Fixing: Glue (recommended – LOCTITE 648 or 2701)

### Magnet for direct recessing in non-ferrous shafts

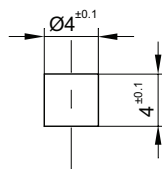

Fixing: Glue (recommended – LOCTITE 648 or 2701)

#### Part numbers:

For resolutions up to 9 bit absolute (512 cpr incremental)

**RMM44A2A00** (individually packed) – for sample quantities only

**RMM44A2C00** (packed in tubes)

For resolutions from 10 bit absolute (800 cpr incremental) and above

**RMM44A3A00** (individually packed) – for sample quantities only

**RMM44A3C00** (packed in tubes)

## Head office

---

### **RLS merilna tehnika d.o.o.**

Poslovna cona Žeje pri Komendi  
Pod vrbami 2  
SI-1218 Komenda  
Slovenia

**T** +386 1 5272100

**F** +386 1 5272129

**E** [mail@rls.si](mailto:mail@rls.si)

**www.rls.si**

## Document issues

Issue	Date	Page	Amendments done
1	29. 4. 2016	-	New document
2	14. 7. 2016	3	Zeroing pads added
3	2. 6. 2017	1	RoHS logo added
		4	Zeroing procedure added