

Orbis™

Through-hole Rotary encoder

Orbis™ is a true absolute rotary encoder suitable for applications where a typical OnAxis encoder cannot be mounted at the end of the rotating shaft due to space limitations or where a hollow shaft is required. Orbis through-hole measuring principle allows customisation with various board and magnet sizes to suit your application.

EASY
INSTALLATION

14 BIT
RESOLUTION

MULTITURN
COUNTER



Features and benefits

- ▶ True absolute
- ▶ 14 bit resolution
- ▶ Multiturn counter option
- ▶ Through-hole design
- ▶ Built-in self-diagnostics
- ▶ Optional self-calibration after installation
- ▶ Integrated status LED
- ▶ BiSS C, SSI, SPI, Asynchronous serial and PWM communication interfaces
- ▶ Wide installation tolerances



GIMBALS



AGVs



MOTOR FEEDBACK
AND COMMUTATION



ROBOTIC JOINTS



AGRICULTURAL
AUTOMATION

General information

The encoder consists of a diametrically magnetized permanent ring magnet and a printed circuit board. The geometrical arrangement of RLS' proprietary Hall sensors on the PCB enables the generation of one period of sine and cosine signals per mechanical magnetic revolution. In addition, it also allows cancelation of the third harmonic component.

An adaptive filtering function provides high resolution at low rotation speeds and low angular phase delay at high rotation speeds. Orbis also has an additional built-in self-calibration algorithm that improves the accuracy of the encoder after installation.

For output Sin/Cos and Commutation see **BRD14** data sheet at [RLS Media Center](#).

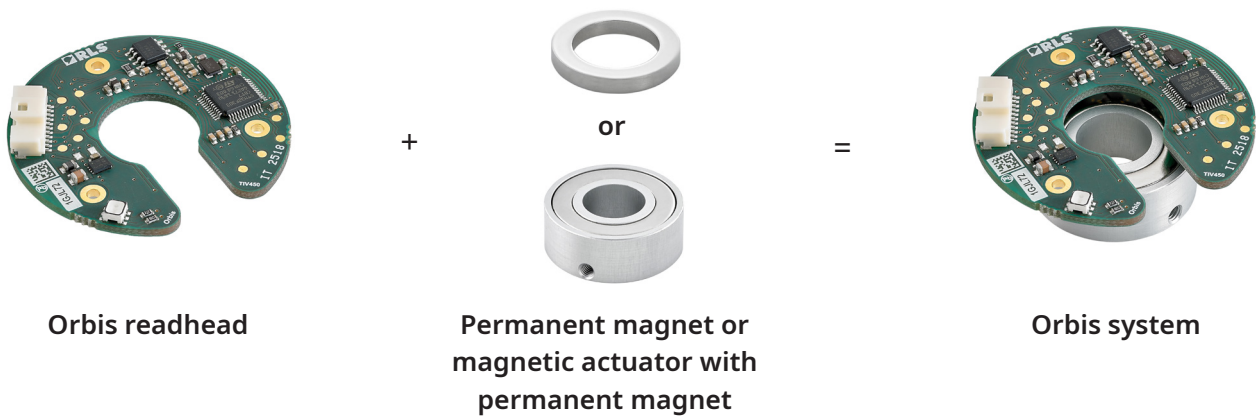

Choose your Orbis magnetic encoder system

Orbis BR10 system



For installations on shaft diameters up to 15 mm.

Orbis BR20 system



For installation on shaft diameters up to 22 mm.

Orbis BR30 system

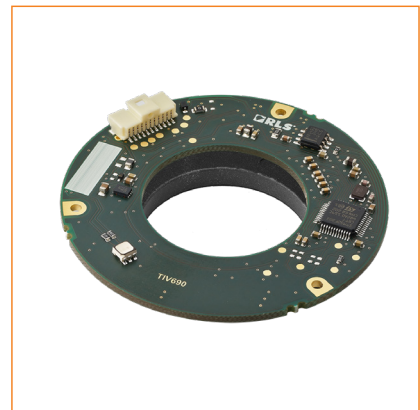

For installation on shaft diameters up to 30 mm.

Storage and handling

Storage temperature



With connector
-40 °C to +105 °C

Without connector
+15 °C to +30 °C (before soldering)
-40 °C to +105 °C (after wires are soldered)

Operating temperature



-40 °C to +105 °C

Humidity



With connector
Up to 70% non- condensing

Without connector
Up to 10 % (before soldering)
Up to 70 % non-condensing (after wires are soldered)

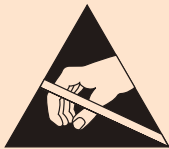

Readhead is ESD sensitive - handle with care.

Do not touch electronic circuit, wires or sensor area without proper ESD protection or outside of ESD controlled environment.

Chemical resistance

RLS products are often used in industrial applications and exposed to chemicals that can affect their internal and external components. While our products are designed to be resistant to many harsh chemicals and environments, long-term resistance will depend on exposure, temperature, and concentration. Most chemicals our products are exposed to are not in continuous contact. Therefore, a material that might not be resistant when submerged in a chemical will last indefinitely when wiped down by that same chemical once a day.

For further information or to confirm compatibility with a chemical in your environment, [contact RLS](#).

Packaging

Less than 20 products are packed individually in an antistatic box. If the order quantity is 20 systems and larger, the parts are packed in antistatic plastic trays. Magnets and readheads are packed separately.

Dimensions and installation drawings

Dimensions and tolerances are in mm. Dimensions without tolerance values are in accordance with ISO 2768-m.



BR10 Readhead

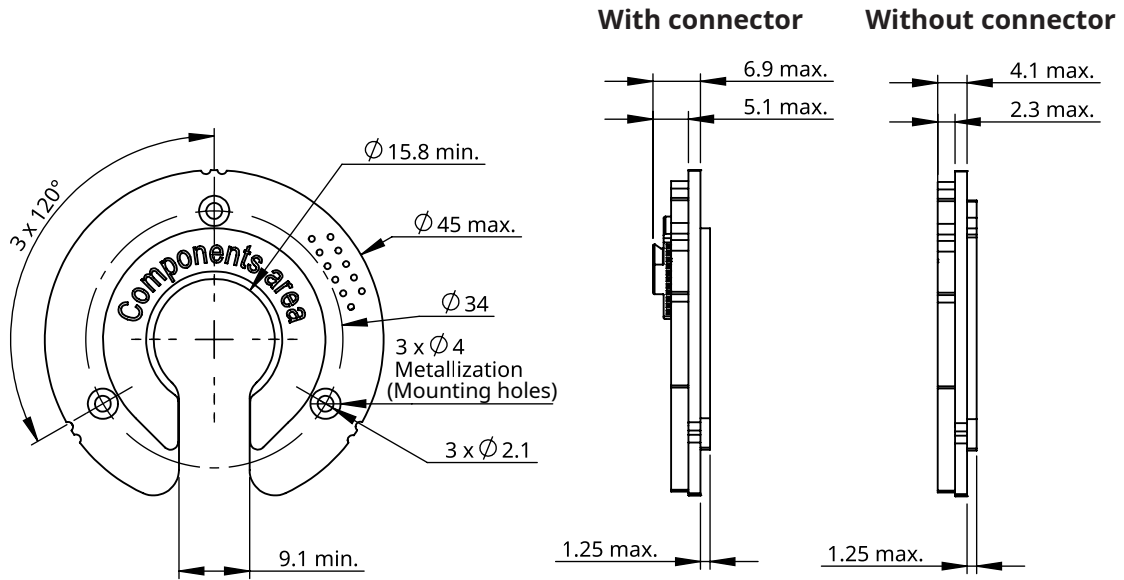

BR20 Readhead

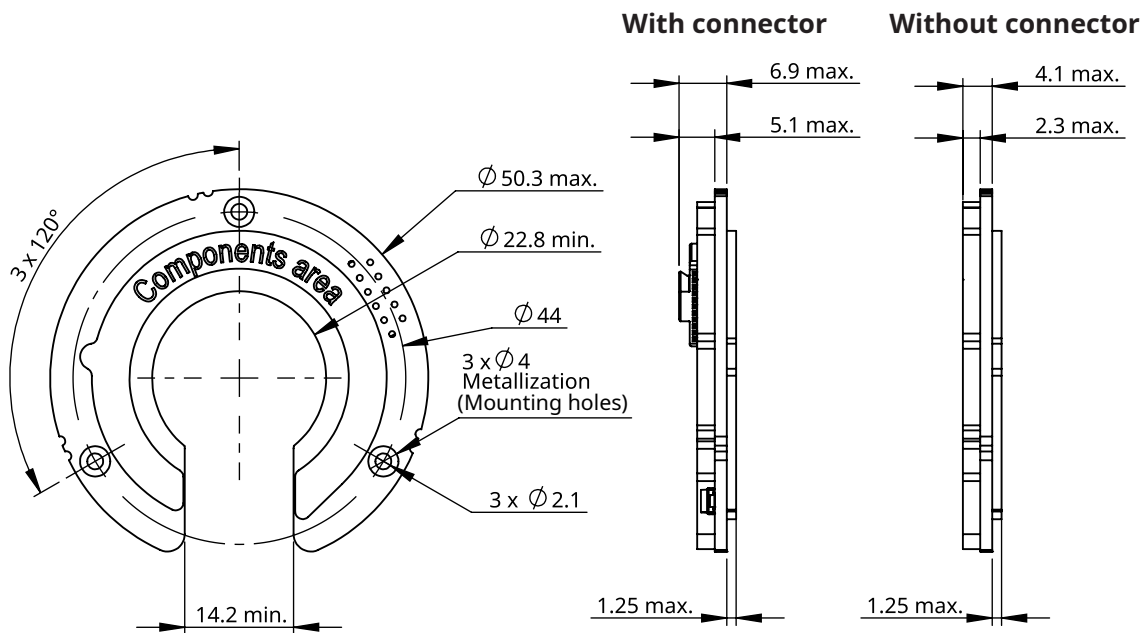

BR30 Readhead

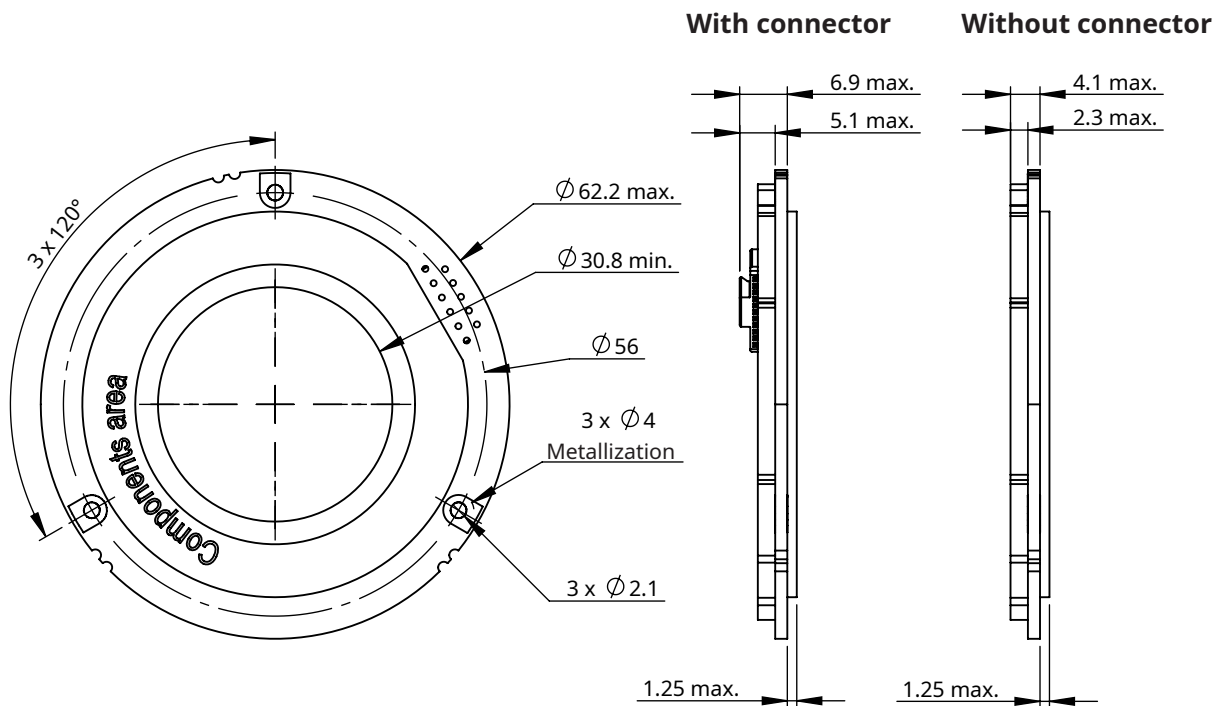

BM magnets and magnetic actuators

Permanent magnet

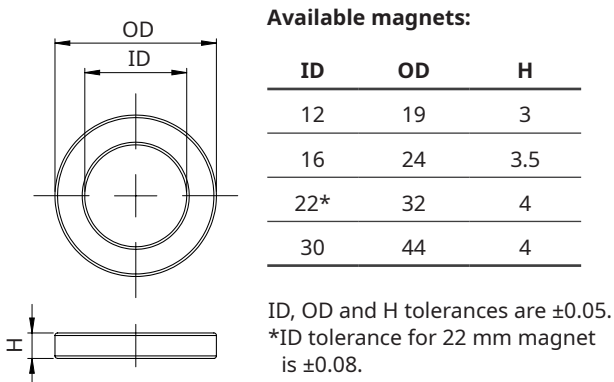

Magnetic actuator (magnet included)

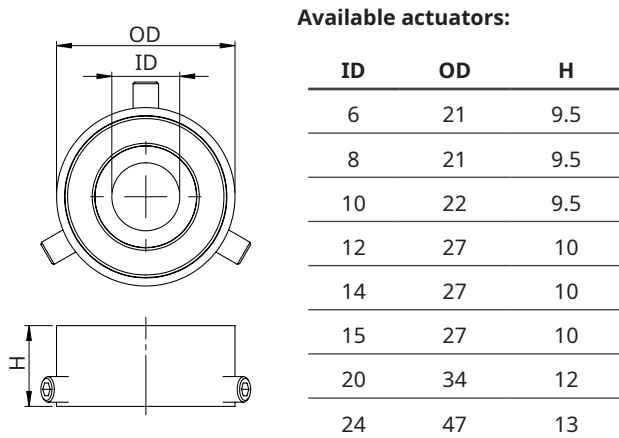

ID tolerances are H7.

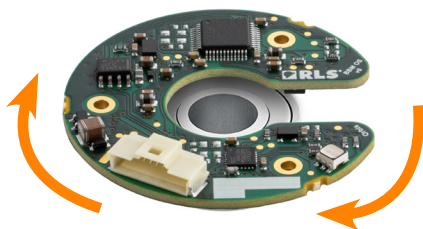

Position increases for clockwise (CW) rotation of magnet.

Installation drawing

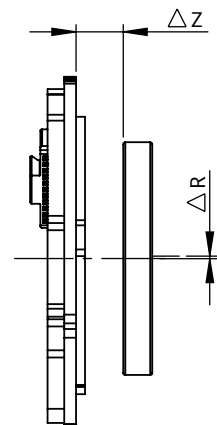
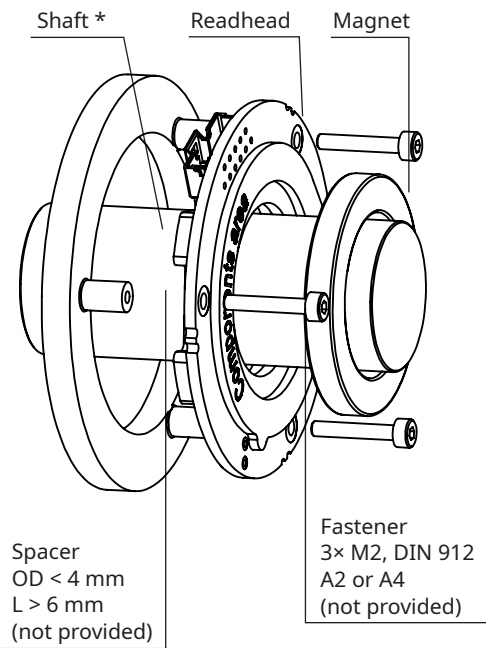
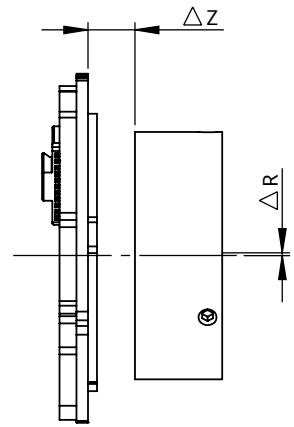
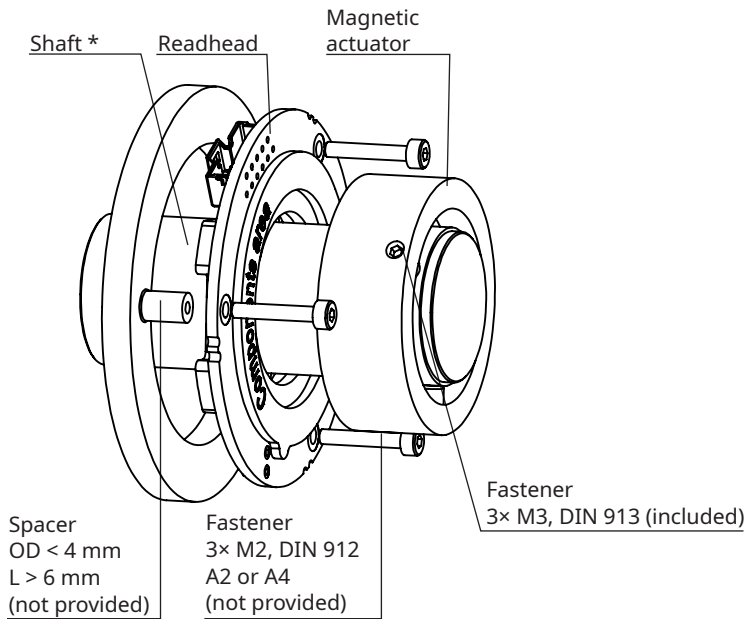

* Recommended shaft tolerance for application with magnetic actuator is g6.

Readhead should only be mounted on the gold plated surfaces around the mounting holes. See **Installation instructions**.

For recommended tightening torques, refer to the document TTD01 available at **RLS Media center**.

The specifications in this data sheet are valid when the magnet is mounted on a non-ferrous shaft. Using a ferrous shaft may affect the encoder's performance. If a ferrous shaft is used, we recommend using an actuator to prevent the magnet from being in direct contact with the ferrous material.

Installation instructions

Installation by gluing

Application

Adhesive mounting uses materials such as industrial adhesives, epoxy resins, or adhesive tapes to join components. Before starting the assembly, always refer to the adhesive manufacturer's instructions. These include critical details such as surface preparation, application method, curing time, and environmental conditions (temperature, pressure, humidity). If no specific instructions are provided, you may follow the standard procedure below as a general guideline:

1. Clean both the shaft and the contact surfaces of the ring with alcohol. The surfaces must be clean, dry and free of dust, oil and grease.
2. Apply the Loctite EA 9514 adhesive evenly around the entire perimeter of the magnet to ensure even bonding and alignment.
3. Cure at a maximum of 130 °C for 45 minutes.

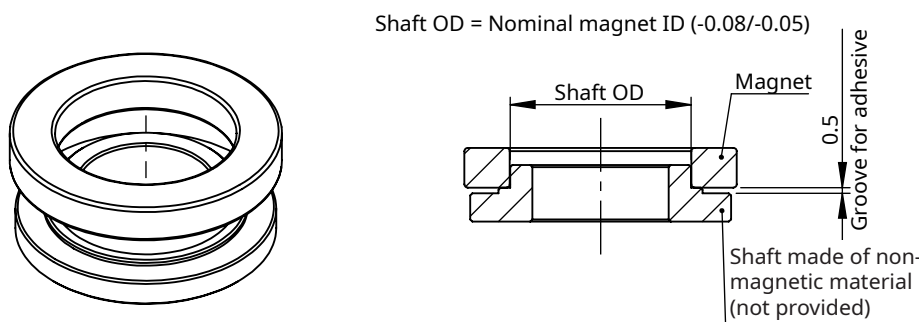

Installation tolerances

Axial (ΔZ) displacement (ride height)*	Magnet with 12 mm ID	4 mm \pm 1 mm
	Magnet with 16 mm ID	5.5 mm \pm 1 mm
	Magnet with 22 mm ID	6.5 mm \pm 1 mm
	Magnet with 30 mm ID	4 mm \pm 1 mm

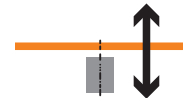

Radial (ΔR) displacement of the sensor Max. 0.5 mm

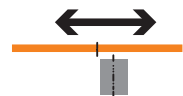

Perpendicularity of readhead 1°

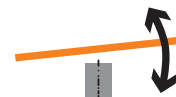

Perpendicularity magnet 2°

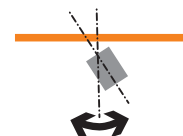

— Readhead ■ Magnet

Precise magnet and readhead installation is key to achieve good overall accuracy.

*See **Installation drawing**.

The specifications in this data sheet are valid when the magnet is mounted on a non-ferrous shaft. Using a ferrous shaft may affect the encoder's performance. If a ferrous shaft is used, we recommend using an actuator to prevent the magnet from being in direct contact with the ferrous material.

Axial position adjustment (ride height)

Any non-magnetic and non-conductive tool can be used to mechanically check for correct ride height adjustment. The integrated LED can be used as a rough indicator. When the correct ride height is achieved, the LED will glow green and should not change colour as the magnet rotates.

External magnetic field

The operating principle of any magnetic encoder is to sense changes in the magnetic field of the magnetic actuator. External magnetic fields generated by permanent magnets, electric motors, coils, magnetic brakes, etc. can affect the operation of the encoder. The accuracy of Orbis is degraded in the presence of magnetic field in radial and axial direction. Axial component is less critical.

Self-calibration after installation

The self-calibration function eliminates eccentricity-related errors, which are a dominant contributor to the accuracy of the encoder and are caused by the eccentric mounting of the ring. This function eliminates the error of one sine wave per revolution. The self-calibration function can be triggered by the user via selected communication interfaces or via using the corresponding USB encoder interface.

For details, refer to the description of the selected communication interface. If the multiturn counter is used in the encoder and the rotational speed is higher than ± 300 RPM, it may have an incorrect value after self-calibration. In this case the multiturn error flag is set.

Requirements:

- Free mechanical rotation for one full revolution (360°).
- Good signal over the entire calibration angle.
- Maximum time available is 10 seconds.
- Direction is not important.
- Maximum speed during self-calibration up to 600 RPM.
- Suitable communication interface (DC, SP or SF) or adapter that allows the function to be triggered.
- Self-calibration must be started when no error is present (green LED).
- When using the SPI encoder version, LED must be visible to check the self-calibration status.

Technical specifications

System data

Reading type	Axial reading
Resolution	14 bit
Repeatability	±2 LSB (counts, unidirectional)
Maximum speed	12,000 rpm
Accuracy	±0.25° (BR10), ±0.3° (BR20), ± 0.5° (BR30)
Accuracy thermal drift	±0.003°/°C
Digital hysteresis	±2 LSB (counts)
Position update rate	50 kHz

Electrical data

Supply voltage	4.5 V to 5.5 V (at the connector)	
Set-up time	100 ms (worst case: 200 ms)	
Current consumption	Typ. 65 mA (no output load)	
Connection	Molex 501568-1107 or soldering pads (through holes)	
Output load	PWM, SPI	Max. ±5 mA at 3.3 V
	RS422	Max. ±100 mA at 5 V
ESD protection	HBM, max. ±2 kV	

Mechanical data

Mass	Readhead	5.3 g
	Magnetic actuator (ID)	6 mm: 6.0 g; 8 mm: 5.5 g; 10 mm: 5.7 g; 12 mm: 8.7 g; 14 mm: 13.7 g 15 mm: 7.1 g; 20 mm: 25 g; 24 mm: 55 g
	Magnet (ID)	12 mm: 3.8 g; 16 mm: 6.4 g; 22 mm: 12.7 g; 30 mm: 16.8 g
Magnet material	12, 16, 22 mm	NdFeB with Ni-Cu-Ni protective layer
	30 mm	NdFeB + epoxy resin
Actuator material		Anodised aluminium

Environmental data

Temperature	Operating	-40 °C to +105 °C
	Storage	-40 °C to +105 °C*
Humidity		0 % to 70 % non-condensing*
External magnetic field		Max. ±10 mT (DC) on top side of readhead. External magnetic field decreases accuracy of encoder.
Shock		100 G (6 ms, standard EN 60068-2-27:2009)
Vibration		40 G (55 Hz – 2000 Hz, standard EN 60068-2-6:2008)

* For limitations see chapter **Storage and Handling**.

Electrical connections

Pin	DC	SF	PW	SC	SP
1			Vdd		
2					
3			GND		
4					
5					
6			-		
7	MA+	RX command in+	Status out	Clock+	SCK
8	MA-	RX command in-	-	Clock-	NCS
9			Cable shield		
10	SLO+	TX data out+	PWM out	Data+	MISO
11	SLO-	TX data out-	-	Data-	MOSI

Pinout

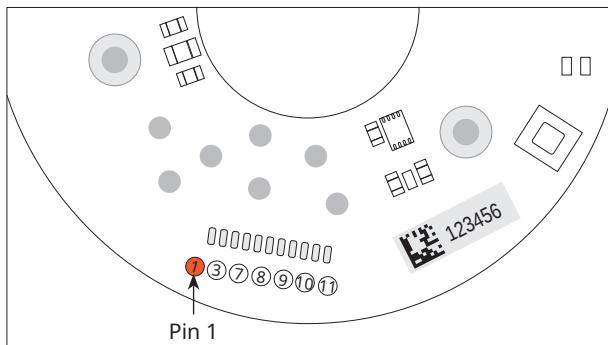

Soldering pads
Size BR10

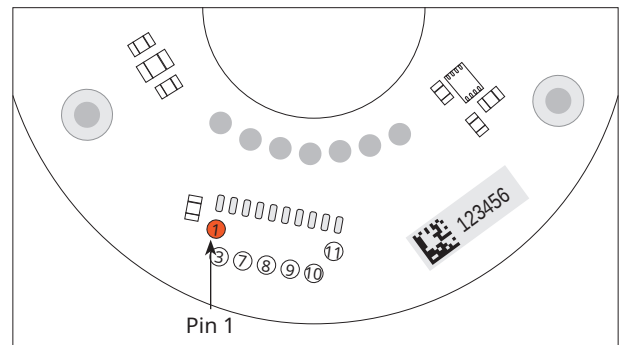

Soldering pads
Size BR20

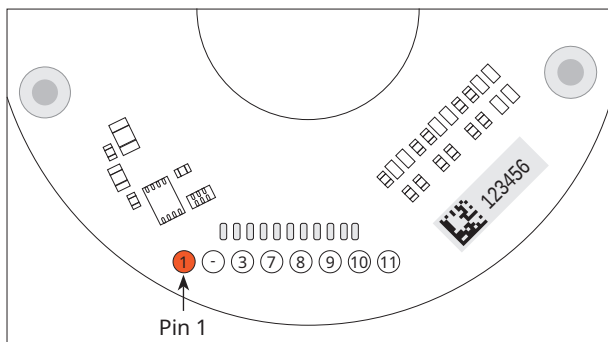

Soldering pads
Size BR30

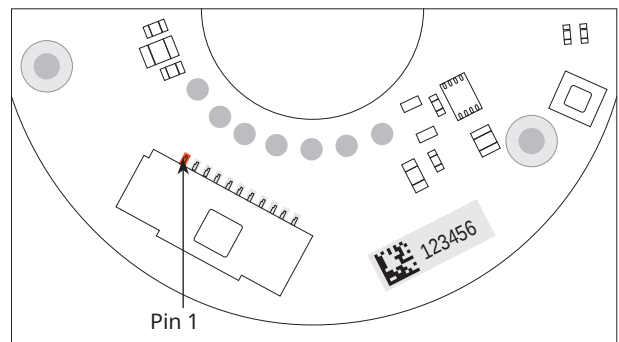

With connector Molex 501568-1107
Sizes BR10, BR20, BR30









Readhead is ESD sensitive - handle with care.

Do not touch electronic circuit, wires or sensor area without proper ESD protection or outside of ESD controlled environment.

Status indicator LED

The LED provides visual feedback of signal strength, error condition and is used for set-up and diagnostic use.

LED	Status
	Green Normal operation; position data is valid.
	Orange Warning; position is valid, but the resolution and/or accuracy might be out of specification. Some operating conditions are outside limits.
	Red Error; position data is not valid.
	Slow flashing Communication has not been established. Position was not requested within last 200 ms. Color of flashing - see above.
	No light No power supply.
	Continuously fast flashing red System error during start-up or operation.
	3 sec. fast flashing Self-calibration results - Refer to the documents BRD04 (Programming Orbis with Asynchronous serial interface) or BRD05 (Orbis BiSS C register access) available at RLS Media center .

Multiturn counter

Multiturn counter is available on the following communication interfaces: **BiSS, Asynchronous serial (UART), SPI and SSI.**

Multiturn option is chosen with **Resolution** in **Part numbering**. Multiturn counter is 16 bit (0 to 65535 counts). Counting is available only when the encoder is powered, but the counter state is stored in a non-volatile memory at power-down and is restored at power-up. Maximum permissible rotation during power-down is $\pm 90^\circ$. If encoder is rotated for $\pm 360^\circ$ or multiple rotations, this movement is not registered and also multiturn error is not set. If any other error is set during a 90° rotation or more, the multiturn counter value might become inconsistent with mechanical position.

Multiturn counter limitations

Counter may have invalid value in following circumstances:

Possible reasons for failure	Solution
If encoder is rotated for $\pm 360^\circ$ or multiple rotations during off state.	Use mechanical brake.
If error flag (red LED) is present for 90° rotation or more.	Read and evaluate error bit.
When encoder has moved for 90° or more or rotating at 300 RPM or more when encoder is performing blocking operation (saving information to non-volatile memory, factory reset, write protect, self-calibration).	Stop rotation before performing those operations.
If user changes single-turn position offset for 90° or more.	Set new multiturn counter value right after setting zero position offset.
If any function for saving information to non-volatile memory (save configuration, factory reset, write protect, self-calibration) is active when power-down happens.	Keep power supply stable when performing those operations.

Multiturn error flag

Error flag is set in one of the following conditions:

- Detected movement of $>90^\circ$ and $<270^\circ$ when powered off,
- detected speed of more than 300 RPM during blocking operation or
- high, unexpected positional difference detected (acceleration error).

Multiturn error bit can be cleared by writing new multiturn counter value into the encoder or by power cycle. Clearing error bit on SSI interface requires power cycle.

Battery powered multiturn counter

Orbis encoder can also be powered by external battery to keep counting the revolutions even when main power is not available. For further information regarding Orbis battery backup multiturn (BBM) refer to the document BRD08 available at [RLS Media center](#).

BiSS C interface

The encoder position, in 14 bit natural binary code, and the encoder status are available through the BiSS C protocol. The position data is left aligned. After the position data there are two status bits (active low) followed by CRC (inverted).

BiSS is implemented for point-to-point operation; multiple slaves are not supported.

Electrical connection

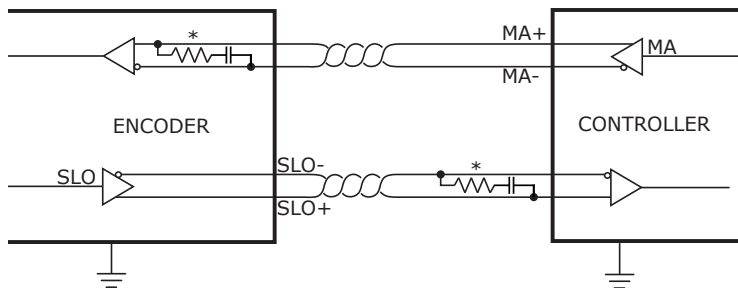

Line signals

MA+	Clock non-inverted signal
MA-	Clock inverted signal
SLO+	Data non-inverted signal
SLO-	Data inverted signal

* The MA and SLO signals are 5 V RS422 compatible differential pairs. MA signal is terminated with RC (100 Ω , 1 nF) inside the encoder.

BiSS C timing diagram (single-turn)

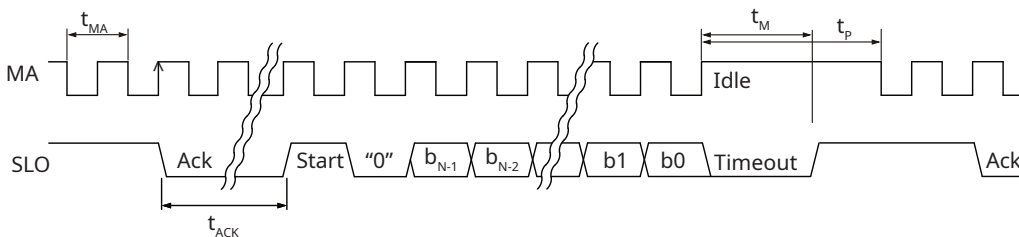

MA is idle high. Communication is initiated with first falling edge.

The encoder responds by setting SLO low on the second rising edge on MA.

When the encoder is ready for the next request cycle it indicates this to the master by setting SLO high.

The absolute position and CRC data is in binary format, left aligned, MSB first.

Communication parameters

Parameter	Symbol	Min	Typ	Max
MA period	t_{MA}	200 ns		10 μ s
MA frequency	f_{MA}	100 kHz		5 MHz
ACK length	t_{ACK}		5 bits	
Transfer timeout	t_M		13.5 μ s	
Pause time	t_p	20 μ s		

Structure of data packet

Bit	b37 : b22	b21 : b8	b7 : b6	b5 : b0
Data length	16 bits	14 bits	2 bits	6 bits
Meaning	Multiturn counter (if specified in part number)	Encoder position	General status	CRC (inverted)

Encoder position

b37 : b22 Multiturn counter (if specified in part number) - Left aligned, MSB first.

b21 : b8 Encoder position – Left aligned, MSB first.

General status

b7 Error - If low, the position data is not valid. Bits b21 - b8 are replaced with error status bits.

b6 Warning - If low, the position data is valid, but some operating conditions are close to limits.

Error and Warning bits can be set at the same time, in this case the Error bit has priority.
The colour of the LED on the readhead housing indicates the value of the General status bits. LED is flashing (duty cycle 50 %, frequency 2.5 Hz), when the encoder is in idle state. If the controller requests the data every 200 ms or more often, the duty cycle of the LED is 100 % (always on).

CRC (inverted)

b5 : b0 Polynomial for CRC calculation of position, error and warning data is: $x^6 + x^1 + 1$. Represented also as 0x43. Number must be inverted before comparison with calculated CRC.

For further information regarding CRC calculation example, refer to the document CRCD01 available at [RLS Media center](#).

Detailed status (in BiSS registers)

b21 : b16 Reserved

b15 Warning: Limit of lower ride height tolerance. Error: Signal amplitude too high. The readhead is too close to the magnet or an external magnetic field is present and too large.

b14 Warning: Limit of upper ride height tolerance. Error: Signal amplitude low. The distance between the readhead and the ring is too large.

b13 Warning: The readhead temperature is out of specified range.

b12 Warning: Speed too high.

b11 Error: Multiturn counter error.

b10 : b8 Reserved.

For more information regarding BiSS protocol see www.biss-interface.com.

Encoder programming

Encoder supports register access which allows setting position offset, multiturn counter, running self-calibration function, configuring the encoder, reading signal level indicator, temperature, detailed status bits and electronic datasheet. It also allows storing up to 4 kB of user data into the encoder (eg. motor parameters, assembly data or similar).

For further information regarding Orbis BiSS C register access, refer to the document BRD05 available at [RLS Media center](#).

Asynchronous serial communication interface over RS422 (UART)

Asynchronous serial communication is supported by a universal asynchronous receiver/transmitter commonly known as UART. It comprises two unidirectional communications channels, forming a full-duplex bidirectional data link. Every channel consists of a two wire differential twisted-pair connection conforming to the RS422 signalling standard.

Electrical connection

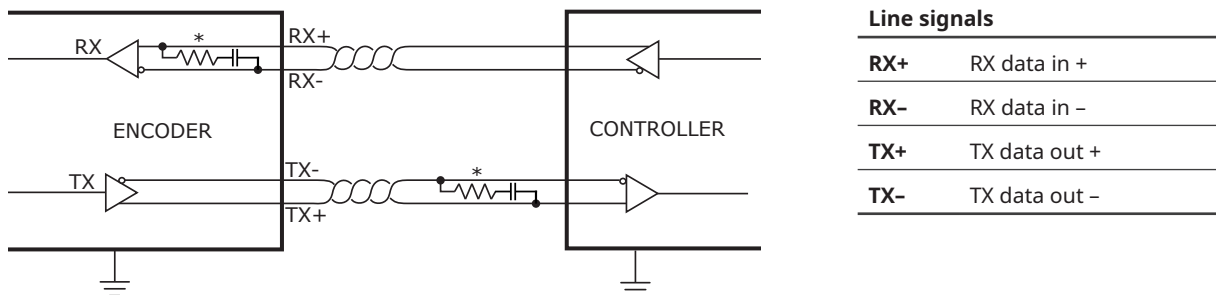

Line signals	
RX+	RX data in +
RX-	RX data in -
TX+	TX data out +
TX-	TX data out -

* The RX and TX signals are 5 V RS422 compatible differential pairs. RX signal is terminated with RC (100 Ω , 1 nF) inside the encoder.

Communication parameters

Character length	8 bits
Parity	None
Stop bits	1
Flow control	None
Bit order	LSB first (standard)

Communication speed is set with the *Communication interface variant* in the part number:

Communication interface variant	A	B	C	D	E	F
Baud rate [kbps]	115.2	128	230.4	256	500	1000

Command set

Command "1" (0x31) – position request

Response 1 byte ASCII "1"
2 bytes (4 for multiturn) hex – see Encoder position data structure

Command "3" (0x33) – short position request

Response 2 bytes (4 for multiturn) hex – see Encoder position data structure

Command "d" (0x64) – position request + detailed status

Response 1 byte ASCII "d"
2 bytes (4 for multiturn) hex – see Encoder position data structure
1 byte hex – see Detailed status data structure

Command "t" (0x74) – position request + temperature

Response 1 byte ASCII "t"
2 bytes (4 for multiturn) hex – see Encoder position data structure
2 bytes hex – temperature (temperature of the readhead in °C multiplied by 10)
(Signed binary) Temperature of the sensor in (°C). This value is typically 10 °C to 15 °C higher than ambient.
Tolerance of the readout is ±5 °C.

Command "v" (0x76) – serial number

Response 1 byte ASCII "v"
6 bytes ASCII – serial number

Encoder position data structure

Encoder position

b31 : b16 Multiturn counter (if specified in part number) - Left aligned, MSB first.

b15 : b2 Encoder position – Left aligned, MSB first.

General status

b1 Error - If low, the position data is not valid. The last valid position is sent out.

b0 Warning - If low, the position data is valid, but some operating conditions are close to limits.

Error and Warning bits can be set at the same time, in this case the Error bit has priority.

The colour of the LED on the readhead housing indicates the value of the General status bits. LED is flashing (duty cycle 50 %, frequency 2.5 Hz), when the encoder is in idle state. If the controller requests the data every 200 ms or more often, the duty cycle of the LED is 100 % (always on).

Detailed status

b7 Warning: Limit of lower ride height tolerance. Error: Signal amplitude too high. The readhead is too close to the magnet or an external magnetic field is present and too large.

b6 Warning: Limit of upper ride height tolerance. Error: Signal amplitude low. The distance between the readhead and the ring is too large.

b5 Warning: The readhead temperature is out of specified range.

b4 Warning: Speed too high.

b3 Error: Multiturn counter error.

b2 : b0 Reserved.

Encoder programming

Encoder supports changing default baud rate, position offset, multiturn counter, running self-calibration function, automatic transmission of selected data packet at programmable frame rate.

For further information regarding Programming encoders with Async serial interface can be found in the document BRD04, available for download at [RLS Media center](#).

PWM - Pulse width modulation interface

The PWM interface transmits the information about the absolute angle position over the pulse width modulated PWM Out signal. An additional digital Status signal indicates the encoder's error condition.

Electrical connection

The Status and PWM Out signals are 3.3 V LVTTTL compatible. These signals have weak ESD protection. Handle with care. Maximum current sourced from or sunk into signal lines should not exceed 5 mA.

Status signal

The Status signal indicates the current status of the encoder. The Status signal is high for normal operation and valid position information. The low state of the Status signal indicates an error state of the encoder which can be caused by:

- Operation outside the installation tolerances,
- sensor malfunction,
- system error or
- no power supply.

When the Status signal is low, the PWM Out signal is low and no pulses are output.

The encoder position is latched on the rising edge of the PWM Out signal. The Status signal should also be checked at the rising edge of the PWM Out signal. If the Status signal changes during the PWM period, it does not affect the currently transmitted position information.

PWM Out signal

The PWM Out is a pulse width modulated output with 14-bit resolution whose duty cycle is proportional to the measured position. The change of the pulse width by PW_{min} corresponds to a change in position by one count (change in angle for $360^\circ / 65536 \approx 0.00549^\circ$).

PWM Out signal timing diagram

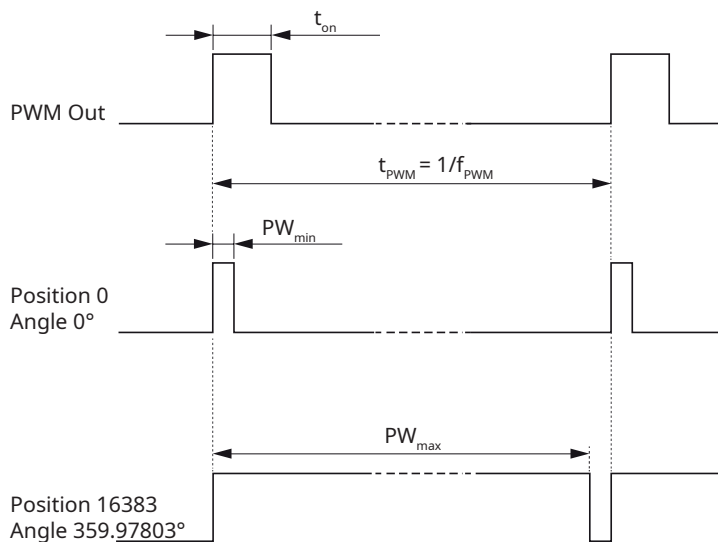

Communication parameters

Communication interface variant in the part number defines the PWM frequency and all other dependent parameters.

Parameter	Symbol	Communication interface variant			Unit	Note
		A	D	E		
PWM frequency	f_{PWM}	122.07	549.32	1098.63	Hz	
Signal period	t_{PWM}	8192	1820.44	910.22	μs	
Minimum pulse width	PW_{min}	0.5	0.111	0.0556	μs	Position 0 (Angle 0°)
Maximum pulse width	PW_{max}	8191.5	1820.33	910.17	μs	Position 16383
Min. counter frequency	f_{CNTR}	2	9	18	MHz	
Resolution		14	14	14	Bit	

$$\text{Position [counts]} = \frac{(t_{\text{on}} - \text{PW}_{\text{min}}) \times 16383}{\text{PW}_{\text{max}} - \text{PW}_{\text{min}}}$$

SSI - Synchronous serial interface

The encoder position, in 14 bit natural binary code, and the encoder status are available through the SSI protocol. The position data is left aligned. After the position data there are two general status bits followed by the detailed status information.

Electrical connection

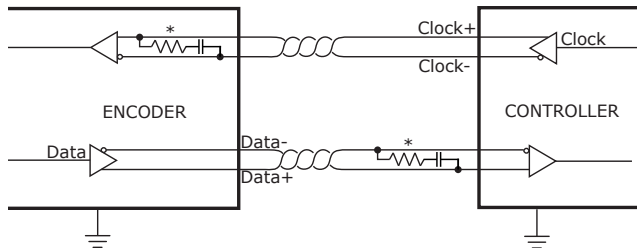

Line signals

Clock+	Clock non-inverted signal
Clock-	Clock inverted signal
Data+	Data non-inverted signal
Data-	Data inverted signal

* The Clock and Data signals are 5 V RS422 compatible differential pairs. Clock signal is terminated with RC (100 Ω, 1 nF) inside the encoder.

SSI timing diagram

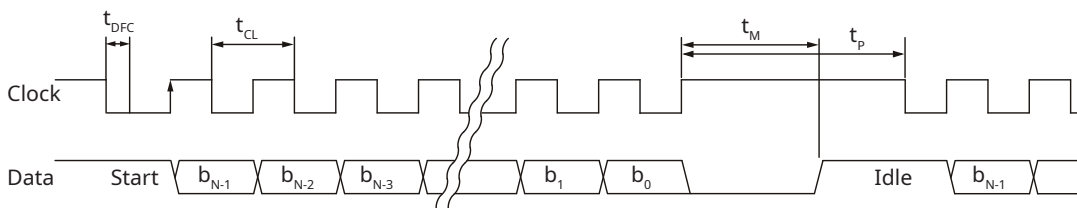

The controller requests the position and status data of the encoder by sending a pulse train to the Clock input. The Clock signal always starts from high. The first falling edge of the Clock latches the last position data available and on the first rising edge of the Clock the most significant bit (MSB) of the position is transmitted to the Data output. The Data output should then be read on the following falling or rising edge. On subsequent rising edges of the Clock signal the next bits are transmitted.

After the transmission of the last bit the Data output goes to low. When the t_M time expires, the Data output goes high. The Clock signal must remain high for at least t_P before the next reading can take place.

While reading the data, the half of a Clock period t_{CL} must always be less than t_M . However, reading the encoder position can be terminated at any time by setting the Clock signal to high for the duration of t_M .

Communication parameters

Parameter	Symbol	Min	Typ	Max
Clock period	t_{CL}	2 μs (400 ns *)		15 μs
Clock frequency	f_{CL}	70 kHz		500 kHz (2.5 MHz *)
Delay first clock	t_{DFC}	1.25 μs		13 μs
Transfer timeout	t_M		14 μs	
Pause time	t_P	20 μs		

* With *Delay First Clock* function of the controller.

Structure of data packet

Bit	b39 : b24	b23 : b10	b9 : b8	b7 : b0
Data length	16 bits	14 bits	2 bits	8 bits
Meaning	Multiturn counter (if specified in part number)	Encoder position	General status	Detailed status

Encoder position

b39 : b24 Multiturn counter (if specified in part number) - Left aligned, MSB first.

b23 : b10 Encoder position – Left aligned, MSB first.

General status

b9 Error - If high, the position data is not valid. The last valid position is sent out.

b8 Warning - If high, the position data is valid, but some operating conditions are close to limits.

Error and Warning bits can be set at the same time, in this case the Error bit has priority.

The colour of the LED on the readhead housing indicates the value of the General status bits. LED is flashing (duty cycle 50 %, frequency 2.5 Hz), when the encoder is in idle state. If the controller requests the data every 200 ms or more often, the duty cycle of the LED is 100 % (always on).

Detailed status

b7 Warning: Limit of lower ride height tolerance. Error: Signal amplitude too high. The readhead is too close to the magnet or external magnetic field is present and too large.

b6 Warning: Limit of upper ride height tolerance. Error: Signal amplitude low. The distance between the readhead and the ring is too large.

b5 Warning: The readhead temperature is out of specified range.

b4 Warning: Speed too high.

b3 Error: Multiturn counter error.

b2 : b0 Reserved.

SPI - Serial peripheral interface

The Serial Peripheral Interface (SPI) bus is a four wire bidirectional synchronous serial communication interface, typically used for short distance communication. It operates in full duplex mode, where master (controller) selects the slave with NCS line, generates clock signal on SCK line, sends command over MOSI line and receives data over MISO line.

Electrical connection

All data signals are 3.3 V LVTTTL. Inputs are 5 V tolerant. Maximum current sourced or sunk from signal lines should not exceed 20 mA. Single-ended signals should be as short as possible, especially if high frequencies are used.

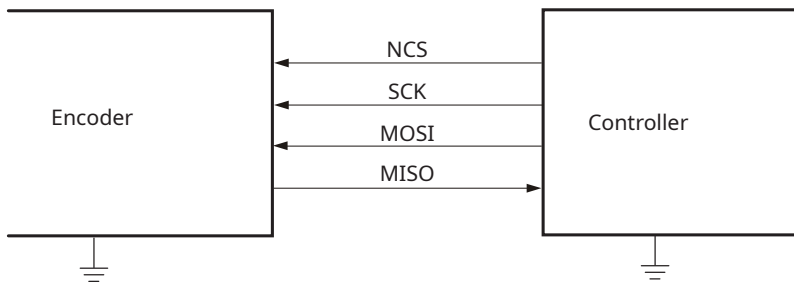

Signal	Description
NCS	Active low. NCS line is used for synchronisation between master and slave devices. During communication it must be held low. Idle is high. When NCS is high, MISO line is in high-Z mode. This allows connection of multiple slaves in parallel, sharing all lines except NCS.
SCK	Serial clock. Shifts out the data on rising edge.
MOSI	Master output → Slave input. Command from the controller to encoder.
MISO	Master input ← Slave output. Data is output on rising edge on SCK after NCS low. When NCS is high, MISO line is in high-Z mode.

SPI timing diagram

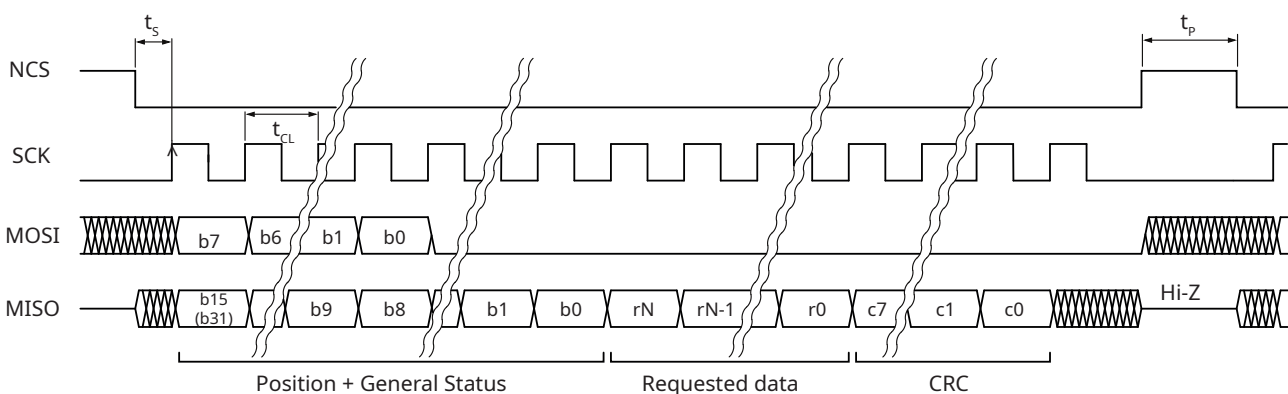

The controller starts communication by setting the NCS signal low. At the same time, the last available position data is latched. A delay of t_s is required to allow the encoder to prepare the data to be shifted to the output MISO on rising edges of the clock signal SCK. The command is received on 8 consecutive rising edges of SCK. Regardless of the command received, 16 bits of Position and General Status data (active low) are sent out. The following length of the requested data and the content depend on the command. The last eight bits contain CRC (inverted) of the complete data packet.

Communication parameters

Parameter	Symbol	Min	Max
Clock period	t_{CL}	250 ns	
Clock frequency	f_{CL}		4 MHz
Time after NCS low to first SCK rising edge	t_s	9 μ s for 14B resolution 14 μ s for 14M resolution	
Pause time	t_p	20 μ s	
Frame rate			$(1 / (t_s + (\text{Data length} / f_{CL}) + t_p))$ Hz

Structure of data packet

Bit	b31 : b16	b15 : b2	b1 : b0	rN : r0	c7 : c0
Data length	16 bits	14 bits	2 bits	Variable	8 bits
Meaning	Multi-turn counter (if specified in part number)	Encoder position	General status	Requested data	CRC (inverted)

Encoder position - for all commands

b31 : b16 Multi-turn counter (if specified in part number) - Left aligned, MSB first.

b15 : b2 Encoder position - Left aligned, MSB first.

General status - for all commands

b1 Error - If low, position data is not valid. Last valid position is sent out.

b0 Warning - If low, position data is valid, but some operating conditions are close to limits.

Error and Warning bits can be set at the same time, in this case Error bit has priority.

The color of the LED on the readhead housing indicates the value of the General status bits. LED is flashing (duty cycle 50 %, frequency 2.5 Hz), when the encoder is in idle state. If the controller request the data every 20 ms or more often, the duty cycle of the LED is 100 % (always on).

Requested data - Command "v" (0x76) - serial number request

r47 : r0 6 bytes (48 bits) of ASCII serial number.

Requested data - Command "t" (0x74) - temperature request

r15 : r0 16 bits, signed. Number represents temperature of the readhead in °C multiplied by 10.

Requested data - Command "d" (0x64) - detailed status request

r7 Warning: Limit of lower ride height tolerance. Error: Signal amplitude too high. The readhead is too close to the magnet or an external magnetic field is present and too large.

r6 Warning: Limit of upper ride height tolerance. Error: Signal amplitude low. The distance between the readhead and the ring is too large.

r5 Warning: The readhead temperature is out of specified range.

r4 Warning: Speed too high.

r3 Error: Multiturn counter error.

r2 Reserved.

r1 Error: Measured acceleration too high. Check magnet mounting.

r0 Error: Safety comparison error. Latched. Power cycle to clear.

Requested data - Command "a" (0x61) - Signal level

r15 : r0 16 bits, unsigned. Value represents air gap distance between magnet and readhead. Use formula to calculate gap in millimeters.

Requested data - Command "i" (0x69) - Self-calibration procedure result

b7 Procedure has finished.

b3 Error. Calibration was not successful.

b2 Error. Timeout has expired. Magnet did not make one full turn in 10 seconds.

b1 : b0 Counter increments after every procedure completion.

Requested data - Command "f" (0x66) - Firmware version

Returns 7 bytes, without position and CRC.

B6 : B5 Must be discarded.

B4 8 bits unsigned. Firmware version major.

B3 8 bits unsigned. Firmware version minor.

B2 8 bits unsigned. Comm driver version.

B1 : B0 16 bits unsigned. Firmware commit number.

Requested data - Command "p" (0x70) - Part number of the encoder

Returns 18 bytes, without position and CRC.

B17 : B16 Must be discarded.

B15 : B0 16 ASCII characters with readhead's part number.

CRC (inverted)

c7 : c0 Polynomial for CRC calculation of the sent data is: $x^8 + x^7 + x^4 + x^2 + x + 1$. Represented also as 0x97. Number must be inverted before comparison with calculated CRC.

For further information regarding CRC calculation example, refer to the document CRCD01 available at [RLS Media center](#).

If command byte does not match any of listed commands, encoder will send only Position, Status, CRC data. If additional data is not required, MOSI line of the encoder should be tied to GND.

Encoder programming

Encoder supports setting position offset, presetting multiturn counter value and running self-calibration function.

For further information regarding programming encoders with SPI interface can be found in the document BRD09 available at [RLS media center](#).

Part numbering

Readhead

	BR	10	SF	A	14B	16	D	D	00																		
Series	BR - Orbis board-level readhead																										
Size	10 - Magnet type compatibility 12 and 16 20 - Magnet type compatibility 22 30 - Magnet type compatibility 30																										
Communication interface	DC - BiSS C, RS422 PW - Pulse Width Modulation (PWM), LVTTTL SC - Synchronous serial interface (SSI), RS422 SF - Asynchronous serial, RS422 SP - SPI (Serial peripheral interface), LVTTTL																										
Communication interface variant	See table next to the description of the chosen communication interface for detailed information For DC: D - BiSS C, 5 ACK bits, bidirectional For PW: Base frequency in Hz: <table border="1" data-bbox="145 1052 391 1120"> <thead> <tr> <th>A</th> <th>D</th> <th>E</th> </tr> </thead> <tbody> <tr> <td>122.07</td> <td>549.32</td> <td>1098.63</td> </tr> </tbody> </table> For SC: B - Start bit and idle data line 1 For SF: Link speed in kbps: <table border="1" data-bbox="145 1187 558 1254"> <thead> <tr> <th>A</th> <th>B</th> <th>C</th> <th>D</th> <th>E</th> <th>F</th> </tr> </thead> <tbody> <tr> <td>115.2</td> <td>128</td> <td>230.4</td> <td>256</td> <td>500</td> <td>1000</td> </tr> </tbody> </table> For SP: C - Standard, full duplex									A	D	E	122.07	549.32	1098.63	A	B	C	D	E	F	115.2	128	230.4	256	500	1000
A	D	E																									
122.07	549.32	1098.63																									
A	B	C	D	E	F																						
115.2	128	230.4	256	500	1000																						
Resolution	14B - 14 bits per revolution 14M - 14 bits per revolution + 16 bit multiturn counter																										
Magnet type compatibility	12 - BM120A190A1ABA00 or actuator BA060-BA100 16 - BM160B240A1ABA00 or actuator BA120-BA150 22 - BM220C320A1ABA00 or actuator BA200AB03AA00 30 - BM300C440B1BBA00 or actuator BA240AB06AA00																										
Operating temperature range	D - -40 °C to +105 °C																										
Connector option	D - Molex 501568-1107 H - Soldering pads with through holes																										
Special requirements	00 - No special requirements																										

Not all part number combinations are valid. Refer to the table of available combinations on the next page.

Table of available combinations

Series	Readhead size	Communication interface	Communication interface variant	Resolution	Magnet type compatibility	Operating temperature range	Connector option	Special requirements		
BR	10	DC	D	14B	12 / 16	D	D / H	00		
				14M						
		PW	A / D / E	14B						
				14M						
		SC	B	14B						
				14M						
		SF	A / B / C / D / E / F	14B						
				14M						
		SP	C	14B						
				14M						
		20	DC	D					14B	22
									14M	
	PW		A / D / E	14B						
				14M						
	SC		B	14B						
				14M						
	SF		A / B / C / D / E / F	14B						
				14M						
	SP		C	14B						
				14M						
	30		DC	D	14B				30	
					14M					
		PW	A / D / E	14B						
				14M						
SC		B	14B							
			14M							
SF		A / B / C / D / E / F	14B							
			14M							
SP		C	14B							
			14M							

For analogue sin/cos and commutation outputs see BRD14 data sheet at [RLS Media Center](#).

Magnet

BM 220 C 320 A 1 A B A 00

Series

BM - Orbis magnet

Inner diameter

120 - 12 mm
160 - 16 mm
220 - 22 mm
300 - 30 mm

Thickness

A - 3 mm
B - 3.5 mm
C - 4 mm

Outer diameter

190 - 19 mm
240 - 24 mm
320 - 32 mm
440 - 44 mm

Material

A - NdFeB
B - NdFeB + plastic resin

Grade

1 - Grade 1 tested magnet

Surface finishing

A - NiCuNi
B - None

Temperature range

B - -40 °C to 120 °C

Packaging

A - Standard packaging

Special requirements

00 - No special requirements

Not all part number combinations are valid. Refer to the table of available combinations below.

Table of available combinations

Series	Inner diameter	Thickness	Outer diameter	Material	Grade	Surface finishing	Temperature range	Packaging	Special requirements
BM	120	A	190	A	1	A	B	A	00
	160	B	240						
	220	C	320						
	300	C	440	B					

Magnetic actuator

BA 060 AB 01 A A 00

Series

BA - Orbis magnetic actuator

Shaft diameter

060 - 6 mm
080 - 8 mm
100 - 10 mm
120 - 12 mm
140 - 14 mm
150 - 15 mm
200 - 20 mm
240 - 24 mm

Form

AB - With 3 fasteners

Magnet type

01 - BM120A190A1ABA00
02 - BM160B240A1ABA00
03 - BM220C320A1ABA00
06 - BM300C440B1BBA00

Material

A - Anodized aluminium

Packaging

A - Standard packaging

Special requirements

00 - No special requirements

Not all part number combinations are valid. Refer to the table of available combinations below.

Table of available combinations

Series	Shaft diameter	Form	Magnet type	Material	Packaging	Special requirements
BA	060	AB	01	A	A	00
	080					
	100					
	120					
	140		02			
	150					
	200		03			
	240		06			

Accessories



Cable assembly, 1 m

ACC048

ACC012

See chapter **Cable assemblies**.



Cable assembly, 3 m

ACC066

ACC024

See chapter **Cable assemblies**.



Cable assembly, 1 m

ACC067

ACC027

See chapter **Cable assemblies**.



USB interface (for BiSS C communication interface)

E201-9B



USB interface (For SSI communication interface)

E201-9S



Magnet viewer

MM0001

Cable assemblies

Cable specifications

Part numbers	ACC012, ACC024, ACC027	ACC048, ACC066, ACC067
Connector 1	Molex 501330-1100 and 501334-0000	Molex 501330-1100 and 501334-0000
Connector 2	ACC012 and ACC024: Flying leads ACC027: DSUB-9M	ACC048 and ACC066: Flying leads ACC067: DSUB-9M
Wire diameter	5 mm	6.2 mm
Length	ACC012 and ACC027: 1.0 m ACC024: 3.0 m	ACC048 and ACC067: 1.0 m ACC066: 3.0 m
Cable specifications	LI12YC12Y (twisted pairs, shielded, up to +100 °C)	LiYCY (TP) (twisted pairs, shielded, up to +75 °C)
Configuration	4 × 2 × 0.14 mm ²	4 × 2 × 0.14 mm ²
Rated voltage	250 V	350 V
Temperature range	Operating: -30 °C to +100 °C Storage: -40 °C to +105 °C Not valid for cables with DSUB-9 M connector.	Operating: -40 °C to +75 °C (fixed) -5 °C to +70 °C (bending) Storage: -40 °C to +80 °C
Environmental conformation	RoHS conform 73/23/EWG-Guideline CE conform Halogen free	RoHS and REACH compliant Flame-retardant according IEC 60332-1-2 Approvals based on VDE 0812 Classification ETIM 5.0 Class-ID: EC000104

Cables with crimped connectors

ACC027 and ACC067 can be used for direct connection to E201-9S or E201-9B USB encoder interface.

ACC012, ACC024 and ACC027 may be discontinued in future.

Dimensions

Dimensions and tolerances are in mm.

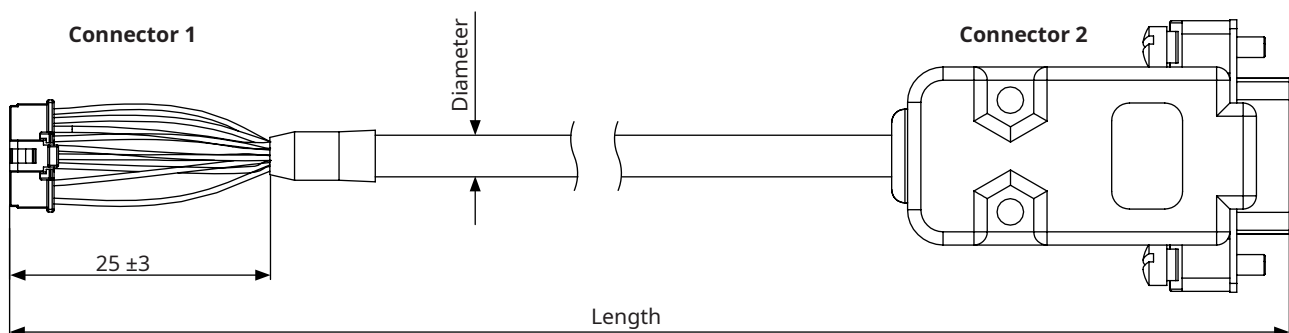

DATA SHEET
BRD01_15

Connector 1		Connector 2		Asynchronous serial		PWM	SSI	SPI
Pin number	Wire color	BiSS C						
1	5	Brown	5 V supply*					
2	-	-						
3	9	White	0 V (GND)*					
4	-	-						
5	8	Pink	-					
6	4	Grey	-					
7	2	Red	MA+	RX command in+	Status out	Clock+	SCK	
8	3	Blue	MA-	RX command in-	-	Clock-	NCS	
9	1	Cable shield						
10	6	Green	SLO+	TX data out+	PWM out	Data+	MISO	
11	7	Yellow	SLO-	TX data out-	-	Data-	MOSI	

*Pins are internally connected on PCB.

Head office

RLS Merilna tehnika d.o.o.

Poslovna cona Žeje pri Komendi
Pod vrbami 2
SI-1218 Komenda
Slovenia

T +386 1 5272100
E mail@rls.si
www.rls.si

Global support

Visit our [website](#) to contact your nearest sales representative.

Document issues

Issue	Date	Page	Description
13	10. 10. 2024	22 - 23	Added functions on the SPI interface (read self-calibration status, signal level, firmware version and part number); SPI timing amended.
14	31. 7. 2025	7	Gluing chapter amended
15	15. 12. 2025	5, 9, 24, 27	Magnetic actuator dimensions changed from 25 to 24

This product is not designed or intended for use outside the environmental limitations and operating parameters expressly stated on the product's datasheet. Products are not designed or intended for use in medical, military, aerospace, automotive or oil & gas applications or any safety-critical applications where a failure of the product could cause severe environmental or property damage, personal injury or death. Any use in such applications must be specifically agreed to by seller in writing, and is subject to such additional terms as the seller may impose in its sole discretion. Use of products in such applications is at buyer's own risk, and buyer will indemnify and hold harmless seller and its affiliates against any liability, loss, damage or expense arising from such use. Information contained in this datasheet was derived from product testing under controlled laboratory conditions and data reported thereon is subject to the stated tolerances and variations, or if none are stated, then to tolerances and variations consistent with usual trade practices and testing methods. The product's performance outside of laboratory conditions, including when one or more operating parameters is at its maximum range, may not conform to the product's datasheet. Further, information in the product's datasheet does not reflect the performance of the product in any application, end-use or operating environment buyer or its customer may put the product to. Seller and its affiliates make no recommendation, warranty or representation as to the suitability of the product for buyer's application, use, end-product, process or combination with any other product or as to any results buyer or its customer might obtain in their use of the product. Buyer should use its own knowledge, judgment, expertise and testing in selecting the product for buyer's application, end-use and/or operating environment, and should not rely on any oral or written statement, representation, or samples made by seller or its affiliates for any purpose. EXCEPT FOR THE WARRANTIES EXPRESSLY SET FORTH IN THE SELLER'S TERMS AND CONDITIONS OF SALE, SELLER MAKES NO WARRANTY EXPRESS OR IMPLIED WITH RESPECT TO THE PRODUCT, INCLUDING ANY WARRANTY OF MERCHANTABILITY OR FITNESS FOR ANY PARTICULAR PURPOSE, WHICH ARE DISCLAIMED AND EXCLUDED. All sales are subject to seller's exclusive terms and conditions of sale which, where the seller is (a) RLS Merilna tehnika d. o. o., are available at <https://www.rls.si/eng/salesterms>, (b) Renishaw, Inc., are available at <https://www.renishaw.com/legal/en/-42186>, or (c) another person, are available on request, and in each case, are incorporated herein by reference, and are the exclusive terms of sale. No other terms and conditions apply. Buyer is not authorized to make any statements or representations that expand upon or extend the environmental limitations and operating parameters of the products, or which imply permitted usage outside of that expressly stated on the datasheet or agreed to in writing by seller.

RLS Merilna tehnika d. o. o. has made considerable effort to ensure the content of this document is correct at the date of publication but makes no warranties or representations regarding the content. RLS Merilna tehnika d. o. o. excludes liability, howsoever arising, for any inaccuracies in this document. © 2025 RLS d. o. o.