

# LA11

## Absolute Magnetic Encoder System

TRUE  
ABSOLUTE  
SYSTEM

ROBUST  
DESIGN

HIGH  
ACCURACY

LA11 is an absolute magnetic linear encoder system designed for motion control applications as a position and velocity control loop element. The versatile design offers various communication outputs and resolution options. It also supports an incremental outputs in parallel to the absolute channel for highly dynamic applications.



LA11 encoder is not recommended for new designs. Please use **Artos**. For more information please contact your local sales representative.

## Features and benefits

- ▶ True absolute system
- ▶ High accuracy
- ▶ Suitable for highly dynamic control loops
- ▶ Robust design and IP68 protection class
- ▶ Speeds up to 7 m/s at 0.976  $\mu\text{m}$  resolution
- ▶ SSI, SPI, BiSS communication protocols and parallel quadrature channel
- ▶ Axis lengths up to 16.3 m
- ▶ Resolutions up to  $\sim 0.244 \mu\text{m}$



MACHINE TOOL



LINEAR MOTOR



ASSEMBLY LINES



INDUSTRIAL AUTOMATION



IN SMALL SIZE

## General information

**The encoder system is highly reliable due to contactless absolute measuring principle, built-in safety algorithms and high quality materials/components used.**

The measuring standard is a magnetic scale which consists of a stainless steel substrate with an elasto-ferrite layer. The elasto-ferrite layer is magnetised with two tracks. The incremental track is magnetised with 2 mm long (alternating south and north) poles and the absolute track is magnetised with a pseudo random binary sequence (PRBS) absolute code with 13 bit length.

The readhead includes Hall sensor arrays for PRBS track reading, and an AMR sensor for incremental track reading, interpolation electronics and custom logic circuitry. The data from the Hall arrays and interpolator are processed in the internal MCU using special algorithms to determine the absolute position. The electronics design provides short response and recovery times. Diagnostic information is available through a chosen serial communication channel and status LED.

### Choose your LA11 system

#### AS10 magnetic scale



Cost-effective magnetic scale for general industrial applications. Available in lengths up to 16.3 m. Can be optionally protected with stainless steel cover foil or integrated into TRS track system.

#### TRS track system (AS10)

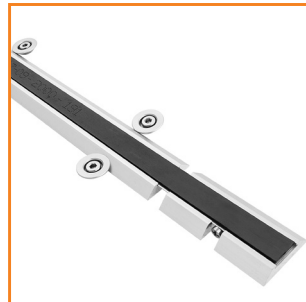

Pre-mounted track system for quick and reliable installation. Ensures optimal scale positioning and enhanced mechanical protection.

#### SAS10 fully welded or exposed



Designed for demanding applications where contamination with industrial compounds is possible. Offers enhanced durability and higher measurement accuracy.

#### Further information

For detailed documentation, compatible scales AS10, SAS10, TRS track system (ASD01) and 3D models, refer to [RLS Media center](#).

# Storage and handling

## Storage temperature



-20 °C to +70 °C

## Operating temperature



0 °C to +55 °C

## Humidity



IP68 rated (readhead)

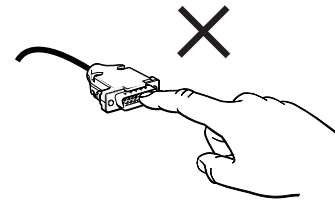
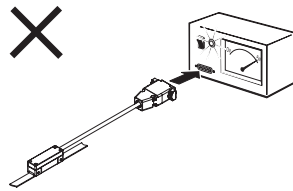
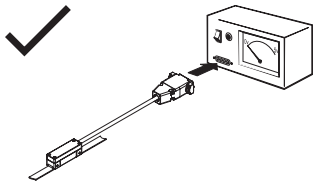

### Readhead is ESD sensitive - handle with care.

Do not touch electronic circuit, wires or sensor area without proper ESD protection or outside of ESD controlled environment.

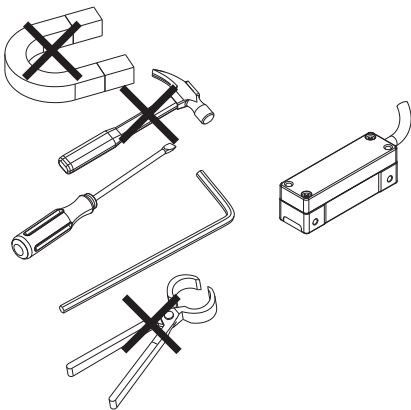

This encoder system is a high performance measuring instrument and should be handled with the same care as any other precision instrument. The use of industrial tools during installation or contact with strong magnets, such as a magnetic base, is not recommended as there is a risk that parts of the system will be damaged and may not function to specifications as a result.

## Packaging

Each readhead is packed individually in an antistatic bag, according to ESD protection measures.

## Labeling/Engraving

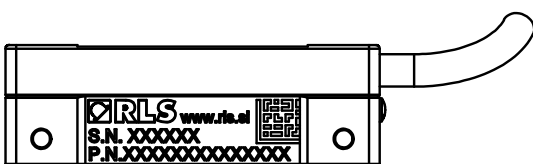

The engraving on the readhead contains a 18-digit part number, a 6-digit serial number and a QR code with a serial number.

# Dimensions drawing

Dimensions and tolerances are in mm. Dimensions without tolerance values are in accordance with ISO 2768-m.

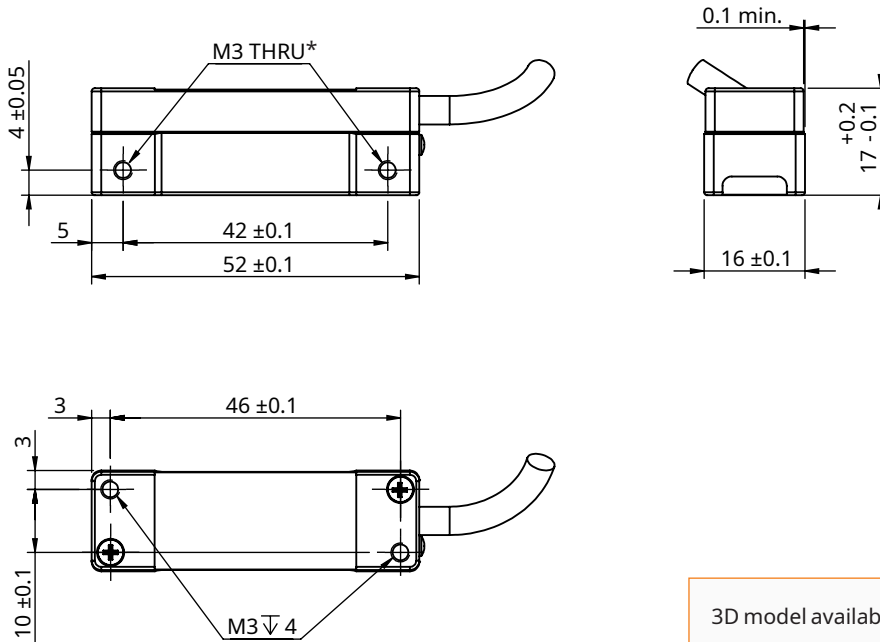

3D model available for download at [RLS Media center](#).

\* The threads (M3) are not anodised and are therefore in direct contact with the aluminium housing and the outer shield.

### General tolerances for linear dimensions according to ISO 2768-m

Tolerance class	up to 6	6-30	30-120
<b>m (medium)</b>	$\pm 0.1$	$\pm 0.2$	$\pm 0.3$

Further information on compatible scales can be found in ASD01 at [RLS Media center](#).

# Installation instructions

The readhead LED must be green at all measuring length positions. Otherwise, the installation will not be performed correctly. The 0.1 mm to 0.6 mm thick plastic spacer (shim) can be used to facilitate installation. For optimal installation, the recommended thickness of the shim is 0.2 mm.

After mounting the magnetic scale, place the plastic shim and the readhead on the magnetic scale. Make sure that the readhead, shim and magnetic scale are in full contact with each other. Ensure that the orientation and alignment of the readhead relative to the magnetic scale is as shown in the ASD01 at [RLS Media center](#). The print on the scale can be used to determine the orientation.

**Improper mounting of the magnetic scale and readhead can impair the function of the magnetic encoder system and lead to total failure.**

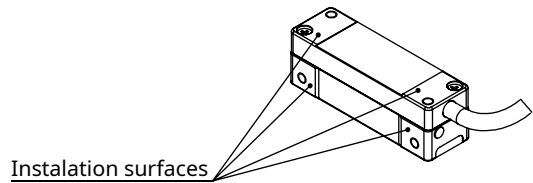

**Variant A**

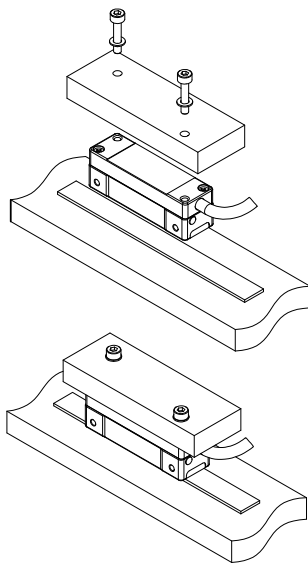

**Variant B**

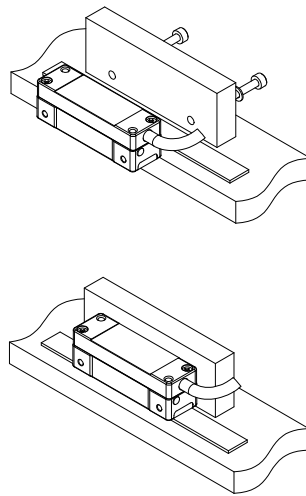

**Variant C**

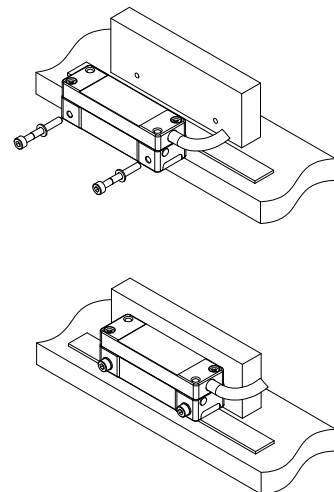

- The magnetic encoder system must be installed and mounted in strict compliance with the installation dimensions and tolerances given on [page 4](#) and in the ASD01 at [RLS Media center](#). Contact between the readhead and magnetic scale must be avoided over the entire measuring range.
- The magnetic encoder system must be used in accordance with the specified degree of protection. The following factors must be taken into account: IP protection class, operating temperature, external magnetic field, mechanical load and EMC compatibility.
- The magnetic encoder system is sensitive to the external magnetic fields. The magnitude of the influence on the magnetic encoder system depends on the magnitude and direction of the external magnetic field. In particular, the rapidly changing stray magnetic fields affect the encoder system and can alter its function. Magnetic field strength within 1 mT reduces the accuracy of the system. Field strengths greater than 1 mT will cause the system to malfunction and as a result the readhead will report an incorrect absolute position with the error status active. Magnetic field strengths greater than 25 mT will cause irreversible damage to the magnetic scale and will have to be replaced.

# Technical specifications

## System data

<b>Incremental pole length</b>		2 mm
<b>Maximum measuring length</b>	<b>AS10</b>	16.3 m
	<b>SAS10</b>	1.288 m
<b>System accuracy</b>	<b>AS10</b>	±30 µm/m
	<b>SAS10</b>	±20 µm/m
<b>Hysteresis</b>		<2 µm at 0.1 mm ride height
<b>Unidirectional repeatability</b>		<1 µm
<b>Maximum resolution</b>		~0.244 µm (see chapter <b>Table of available resolutions</b> )

For more information about accuracy of absolute linear encoder systems refer to AST01 available at **RLS Media center**.  
For more information about accuracy of AS10 or SAS10 magnetic scale refer to ASD01 available at **RLS Media center**.

## Electrical data

<b>Power supply</b>	<b>Option A</b>	From 4.75 V to 5.75 V - Voltage on readhead; Consider voltage drop over cable
	<b>Option B</b>	From 8 to 30 V
<b>Reverse polarity protection</b>		For option A only (5 V power supply)
<b>Set-up time after switch-on</b>		<350 ms (see chapter <b>Power-up ramp specification</b> )
<b>Current consumption (without load)</b>	<b>Option A</b>	< 150 mA at 5 V power supply
	<b>Option B</b>	< 85 mA at 12 V power supply < 50 mA at 24 V power supply
<b>Voltage drop over cable</b>		~80 mV/m (without load) at 5 V power supply
<b>Maximum power supply ramp up time</b>		100 ms (see chapter <b>Power-up ramp specification</b> )
<b>Maximum power supply ripple</b>		200 mV at 30 KHz (see chapter <b>Power-up ramp specification</b> )

## Mechanical data

<b>Material</b>	Readhead: Aluminium (Eloxal - anodised)
<b>Mass</b>	Readhead: (with 1 m cable, no connector) 41 g, magnetic scale 60 g/m

## Environmental data

<b>Temperature</b>	<b>Operating</b>	0 °C to +55 °C
	<b>Storage</b>	-20 °C to +70 °C
<b>Vibrations (55 Hz to 2000 Hz)</b>		30 g (IEC 60068-2-6)
<b>Shocks (11 ms)</b>		30 g (IEC 60068-2-27)
<b>Humidity</b>		100 % (condensation permitted)
<b>EMC Immunity</b>		IEC 61000-6-2
<b>EMC Emission</b>		IEC 61000-6-4
<b>Environmental sealing - readhead</b>		IP68 (according to IEC 60529)
<b>Maximum external magnetic field during operation</b>		1 mT

## Cable

	8 core	12 core	8 core UL with over-mould M12*
<b>Communication outputs</b>	SP	DI, SI, SQ	SP (Termination only with the over-mould sealed M12 connector - "W" option)
<b>Cable type</b>	PUR high flexible cable, braided shield, pairs not twisted		
<b>Outer diameter</b>	4.2 mm ±0.2 mm	4.5 mm ±0.2 mm	Max 4.5 mm
<b>Shield</b>	Double twisted shield	Double twisted shield	Single braided shield
<b>Jacket material</b>	Extruded polyurethane (PUR)		
<b>Wires AWG</b>	White 0.14 mm <sup>2</sup> , 26 AWG, 0.13 Ω/m Other 0.05 mm <sup>2</sup> , 30 AWG, 0.35 Ω/m	All wires 0.08 mm <sup>2</sup> , 28 AWG, 0.23 Ω/m	White and brown 0.14 mm <sup>2</sup> , 26 AWG, 0.14 Ω/m Other wires 0.08 mm <sup>2</sup> , 28 AWG, 0.23 Ω/m
<b>Cable bending radius</b>	Dynamic 25 mm Static 10 mm	Dynamic 50 mm Static 10 mm	Dynamic 50 mm Static 10 mm
<b>Mass</b>	34 g/m	38 g/m	34 g/m
<b>Durability</b>	20 million cycles at 25 mm bend radius	20 million cycles at 50 mm bend radius	10 million cycles at 50 mm bend radius
<b>Torsion</b>	Continuous torsion not allowed		
<b>Maximum cable length</b>	30 m	30 m	15 m

\* The UL 8-core cable is available only with the M12 over-mould connector in predefined cable lengths ("W" option).

## Cable bending radius

Fixed laying application

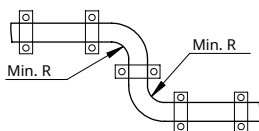

Continuously flexible application

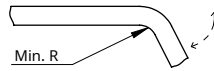

The cable requires adequate strain relief to ensure its integrity and avoid lateral forces that could damage the cable entry. The bending radius of the cable also applies to the connector side.

## Cable installation

Dimensions and tolerances are in mm. Dimensions without tolerance values are in accordance with ISO 2768-m.

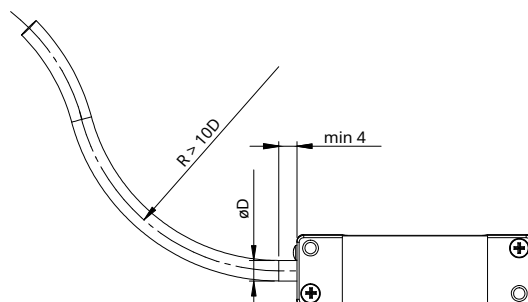

# Electrical connections

## Shield connection

The following figures show the recommended shield termination in order to ensure electromagnetic compatibility. However, correct integration of the encoder system depends on the application.

### 8 and 12 core cable (double shield)

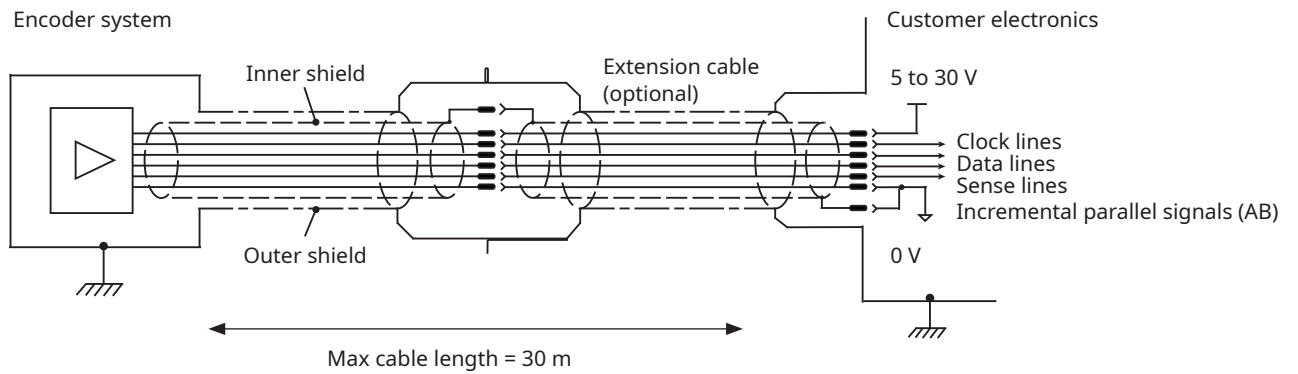

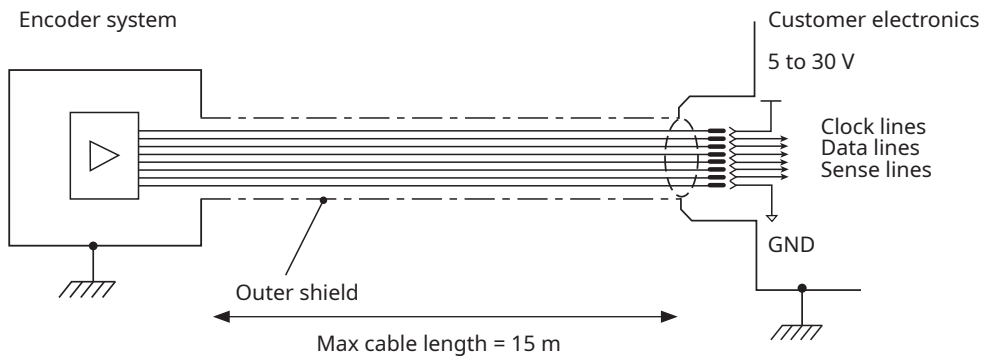

### 8 core UL cable with over-mould M12 connector (single shield)



The encoder housing is galvanically connected to the connector housing. To achieve EMC compliance, the encoder system must be correctly integrated. In particular, attention to shielding arrangements is essential.

# Pinout

## 8 core (single and double shield cables - Output type SP)

Function	Signal	Wire colour (Flying Leads)	9 pin D type plug	M12 8-way (A-coded)
				
Power	+Vin supply	Brown	5	2
	GND supply	White	9	1
	+Vin SENSE*	Grey	4	-
	GND SENSE*	Pink	8	-
Serial communication	CLK_SPI	Green	2	7
	CS_SPI	Yellow	3	6
	MISO_SPI	Blue	6	3
Shield	Inner	Bare wire	1	-
	Outer	Bare wire	Case	Case

\* If controller does not support voltage sense functionality (+Vin SENSE and GND SENSE), we recommend connecting sense lines parallel to power supply lines (GND SENSE to GND, Vin SENSE to Vin) in order to decrease voltage drop over cable. If sense lines are not used and/or connected, they should be isolated in order to prevent possible shorts between power supply lines.

### 9-way D-type connector (male type)

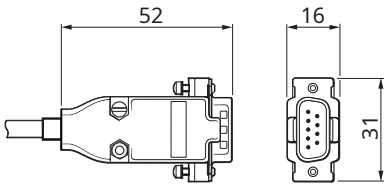

### M12 8-way sealed (overmould) A-coded connector (male type)\*

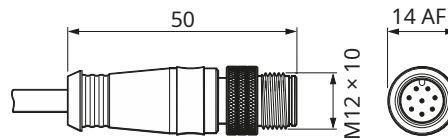

\* The overmould version of M12 is available with a 8-core UL cable. For details refer to the chapter [Cable](#).

12 core (double shield cable - Output types DI, SI, SQ)

15 pin D type plug

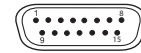

Function	Signal	Wire colour (Flying Leads)	
Power	+Vin supply	Brown	7
	GND supply	White	2
	+Vin SENSE*	Orange	8
	GND SENSE*	Transparent	15
Serial communication	CLK+ / MA+ / CLK_SPI	Green	3
	CLK- / MA- / CS_SPI	Yellow	4
	DATA+ / SLO+ / MISO_SPI	Blue	13
	DATA- / SLO-	Red	14
Incremental outputs	A+	Purple	5
	A-	Black	10
	B+	Grey	6
	B-	Pink	11
Shield	Inner	Bare wire	1
	Outer	Bare wire	Case

\* If controller does not support voltage sense functionality, we recommend connecting sense lines parallel to power supply lines (GND SENSE to GND, Vin SENSE to Vin) in order to decrease voltage drop over cable. If sense lines are not used and/or connected, they should be isolated in order to prevent possible shorts between power supply lines.

15-pin connector pin-out

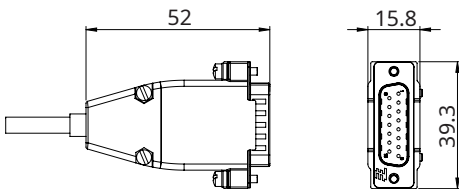

Power-up ramp specification

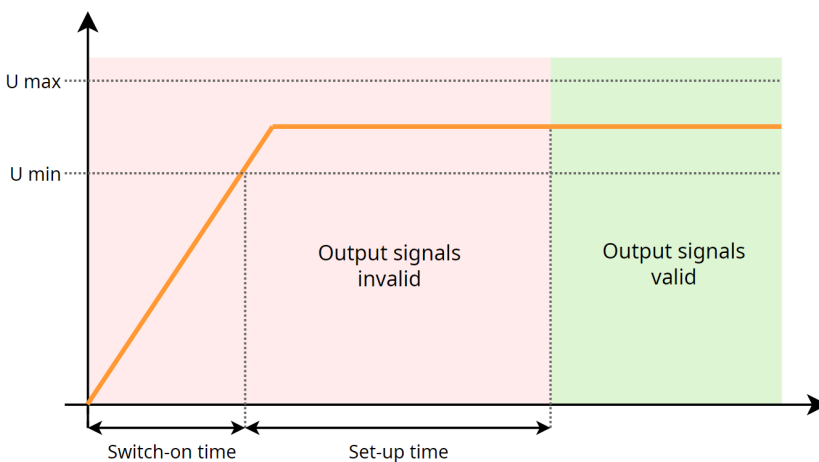

Switch-on time: 100 ms

Set-up time: 350 ms







Maximum power supply ripple: 200 mV at 30 kHz ( $U_{max} - U_{min}$ )

## Status indicator LED

Once the magnetic scale is installed, the readhead can be easily mounted on the machine using the LED setup indicator. The LED indicator shows the internal status of the encoder and is used to facilitate the installation and diagnosis of the encoder system. With BiSS C output the communication between the encoder and master (controller, drive) must be established. With BiSS C only during the communication the position will be internally evaluated and reflected on the LED.



Slow flashing of LED indicates that the encoder is receiving power, but communication between the encoder and the controller has not yet been established. The error status has a higher priority than the warning status in the LED signaling. In case of error/warning the LED remains red/orange for at least 200 ms.

LED Status	Status	Description
 <b>Green</b>	Normal operation	Position data is valid.
 <b>Orange</b>	Warning	<ul style="list-style-type: none"> <li>The internal temperature is near operational limits. (&gt; 80% of maximum temperature). The position is still valid.</li> </ul>
 <b>Red</b>	Error	Position data is not valid. Possible causes: <ul style="list-style-type: none"> <li>The distance between the readhead and the magnetic scale is too large.</li> <li>The readhead is out of alignment with the magnetic scale or it is demagnetised.</li> <li>Incorrect orientation of the readhead or magnetic scale.</li> <li>The encoder speed is out of operational limits.</li> </ul>
 <b>Solid red after power up</b>	Error	Internal system error or power supply too low. The readhead is not possible to communicate.
 <b>Slow red, green or orange flashing</b>	/	The communication between the readhead and master has not been established.
 <b>No light</b>	/	No power supply.

The LED signal statuses listed in the table above do not indicate non-optimal installation of the readhead, e. g. an accuracy outside the specified range.

During installation, it is advisable to move the readhead in both directions over the entire range of motion to observe the encoder status on the LED. As soon as the LED indicator remains green over the entire range of motion, it indicates that the encoder is correctly installed.

## Troubleshooting

If the readhead reports an error during operation due to incorrect decoding of the absolute position on the magnetic scale, this indicates a serious problem. Serious problems include incorrect installation or a damaged magnetic pattern on the scale. To determine the cause of the problem, please proceed as follows:

- Make sure that the part number on the readhead and the scale match the required combination.
- Verify that the installation matches the specification of the encoder for the orientation of the readhead relative to the scale (ride height/radial offset, lateral/axial offset, centerline/ tangential, roll, pitch and yaw offsets).
- If possible, check the error location on the magnetic scale with the magnetic viewer for an abnormal pattern in the magnetic code.
- Check the power supply. This is especially important for longer cable lengths. Take into account the voltage drop over the cable.

## General notes for the controllers

### Resolution of the encoder and controller compatibility

Some controllers are not compatible with a certain type of resolutions that are longer than 3 digits after the point (binary resolutions - 0.244140625  $\mu\text{m}$ , 0.48828125  $\mu\text{m}$ , etc). If the insufficient number is set into the controller, (i.e. 0.244  $\mu\text{m}$ ) the error will accumulate over the linear travel. In such cases, it is recommended that the decimal resolution is selected (i.e. 1.0  $\mu\text{m}$ ).

## General notes for the power supply voltage and its compensation

### Voltage drop over the cable

The voltage drop over the cable must be compensated in the controller if the cable is longer or if the extension cable is used. Some controllers can automatically compensate the power supply voltage based on the sense lines from the readhead.

### Note on the Sense lines

The LA11 readhead supports the sense lines. The sense lines enable the controller to sense the power supply voltage that is applied to the encoder and adjust it based on the readhead specification. If controller does not support voltage sense functionality, we recommend connecting sense lines parallel to power supply lines in order to decrease voltage drop over cable (GNDsense to GND, Vinsense to Vin). If sense lines are not used and/or connected, they should be isolated in order to prevent possible shorts between power supply lines.

## Communication interface options (parallel incremental outputs)

---

Parallel incremental signals	SSI	BiSS	SPI
None	/	/	SP
Incremental quadrature, RS422; 5 V	SI	DI	SQ

# BiSS C interface

The encoder position, in 26 bit natural binary code, and the encoder status are available through the BiSS C protocol. The position data is left aligned, MSB first. After the position data there are two status bits (active low) followed by CRC (inverted).

BiSS C is implemented for point-to-point operation, multiple slaves are not supported.

## Electrical connection

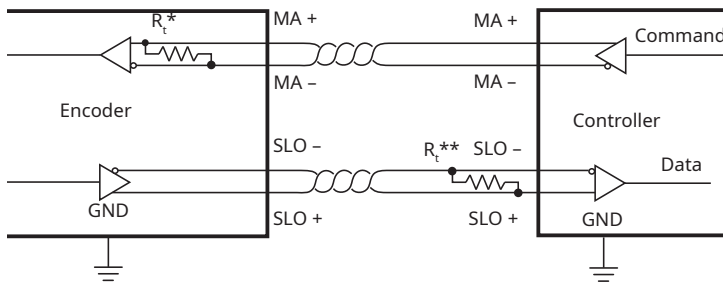

Signals	
<b>MA</b>	Master clock.
<b>SLO</b>	Slave out. Data is output on rising edge on SCK. Data is valid on the falling edge of SCK signal.

\* The MA and SLO lines are 5 V RS422 compatible differential pairs. The termination resistor on the MA line is integrated inside the encoder.

\*\* Termination at the controller is required, if the total cable length is longer than 5 m. The nominal impedance of the cable is 120  $\Omega$ .

## BiSS C timing diagram

Encoder latches position value 500 ns after first falling edge

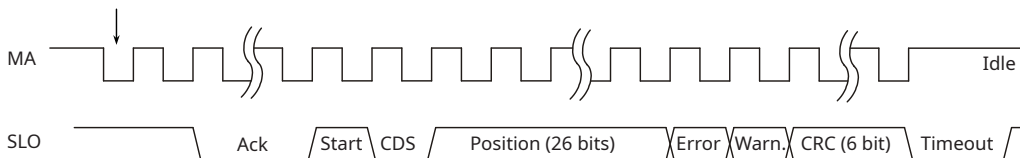

Encoder responds to the controller commands by latching the position value 500 ns after the first falling edge of the MA signal. MA is idle high. Communication is initiated with first falling edge. The encoder responds by setting SLO line low on the second rising edge on MA.

Ack is the period during which the readhead calculates the absolute position. There are two options available: Option A with 12 bit and option B with 20 bit long acknowledge. Acknowledge length determines the maximum MA frequency.

When the encoder is ready for the next request cycle it indicates to the master by setting SLO line high.

The CRC is inverted in binary format and sent MSB first. The absolute position is always 26 bits long regardless of the chosen resolution. It is in binary format and sent MSB first, left aligned, unused lower bits are set to zero. CDS bit is always zero.

## BiSS C Parameters

<b>Interface type</b>		BiSS C unidirectional (point-to-point)
<b>Signal level</b>		RS422
<b>Position data encoding</b>		Pure binary
<b>Maximum MA frequency</b>	<b>Option A</b>	12 bits of acknowledge: 2.2 MHz
	<b>Option B</b>	20 bits of acknowledge: 3.5 MHz
<b>Minimum MA frequency</b>		50 kHz
<b>Length of position data</b>		26 bits (regardless of the resolution chosen). See page 17.
<b>Length and type of status data</b>		2 bits (Error, Warning). Active low. Error/warning descriptions, can be found in the <b>LED Status table</b> .
<b>CRC length and type</b>		6 bits (MSB first, inverted bit output - polynomial 0x43)
<b>ACK length</b>	<b>Option A</b>	12 bits
	<b>Option B</b>	20 bits
<b>CDS bit</b>		Always zero
<b>Communication delay</b>	<b>Option A</b>	5.45 $\mu$ s at 2.2 MHz MA frequency; otherwise 12 MA clock periods
	<b>Option B</b>	5.7 $\mu$ s at 3.5 MHz MA frequency; otherwise 20 MA clock periods
<b>Timeout</b>		$\geq$ 20 $\mu$ s or when the SLO line goes high
<b>Maximum data frame rate</b>	<b>Option A</b>	Up to 23.5 kHz
	<b>Option B</b>	Up to 27.4 kHz

For example of calculation routine for 6-bit CRC please refer to application note CRCD01 available at [RLS Media center](#).  
For more information regarding BiSS protocol see [www.biss-interface.com](http://www.biss-interface.com).

# SSI Communication interface

The encoder position, 26 bit natural binary code, and the encoder status are available through the SSI protocol. The position is captured internally every 10  $\mu$ s (refresh rate 100 kHz). Output position data is the last captured data before position request trigger. Request trigger is a falling edge of clock signal. The position data is left aligned, MSB first. After the position data there are two general status bits (active status low) followed by the detailed status information.

## Electrical connection

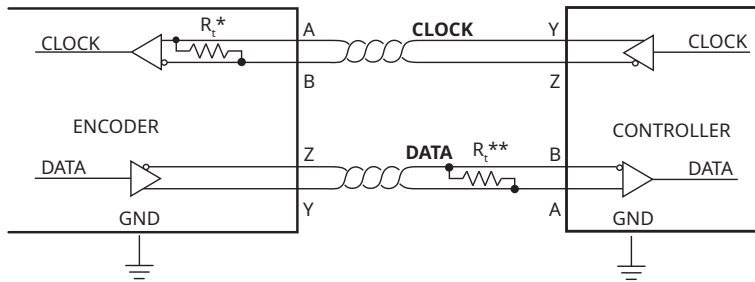

Line signals	
<b>Clock+</b>	Receiver, + input
<b>Clock-</b>	Receiver, - input
<b>Data+</b>	Transmitter, + output
<b>Data-</b>	Transmitter, - output

\* The CLOCK and DATA lines are 5 V RS422 compatible differential pairs. The termination resistor on the CLOCK line is integrated in the encoder.

\*\* Termination at the controller is required if the total cable length is more than 5 m. The nominal impedance of the cable is 120  $\Omega$ .

## SSI timing diagram

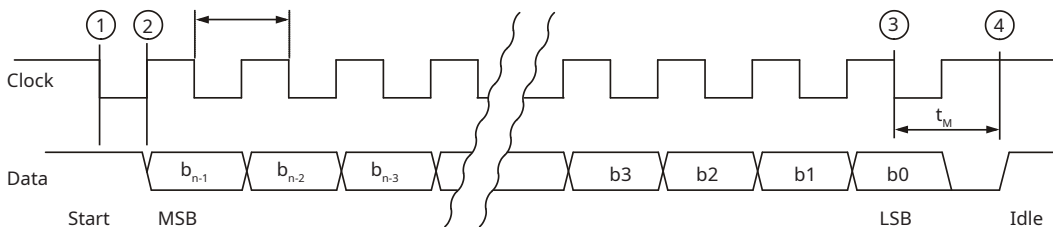

The controller requests the position and status data of the encoder by sending a pulse train to the Clock input. The Clock signal always starts from high. The first falling edge ① latches the last position data available and on the first rising edge ② the most significant bit (MSB) of the position is transmitted to the Data output. If time between ① and ② is extended for additional 1  $\mu$ s the maximum clock frequency limit is 2.5 MHz instead of 0.8 MHz. This function is called "Delay First Clock" and must be supported by the controller.

After the transmission of the last bit ③ the Data output goes to low. When the  $t_M$  time expires, the Data output is logical "H" ④. The Clock signal must remain high for at least  $t_M$  before the next reading can take place. Reading the encoder position can be terminated at any time by setting the Clock signal to high for the duration of  $t_M$ .

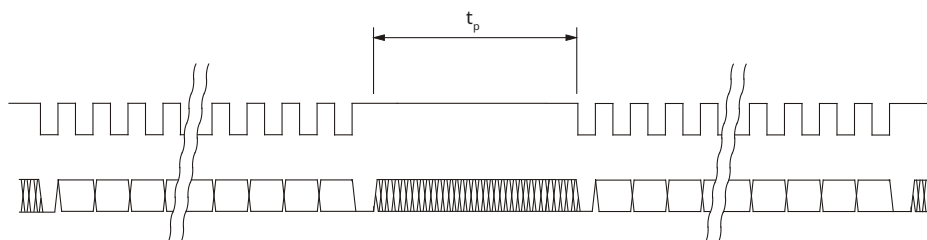

## SSI Parameters

<b>Interface type</b>		SSI unidirectional (point-to-point)
<b>Signal level</b>		RS422
<b>Position data encoding</b>		Pure binary
<b>CLOCK frequency</b>	<b>Maximum</b>	800 kHz (2.5 MHz with first clock delay function on the controller)
	<b>Minimum</b>	100 kHz
<b>Length of position data</b>		26 bits (regardless of the resolution chosen)
<b>Length and type of status data</b>		2 bits (Error, Warning). Active low. Error/warning descriptions, can be found in the <b>LED Status table</b> .
<b>Timeout <math>t_M</math></b>		$\geq 10 \mu s$ or when the DATA line goes high
<b>Max data frame rate</b>	<b>Option A</b>	Position with general and detailed status: Up to 18 kHz (41 kHz*)
	<b>Option B</b>	Position with general status: Up to 22 kHz (47 kHz*)
	<b>Option C and D</b>	Position only (binary and gray format, at 26 bit long data): up to 23 kHz (49 kHz*)
<b>Delay first clock <math>t_{DFC}</math></b>		1 - 10 $\mu s$
<b>Pause time <math>t_p</math></b>		$> 10 \mu s$ (If the reading request arrives earlier than $t_p$ , the encoder position will not be updated)

\* With first clock delay function.

## SSI - position with two general and detailed status bits

Data packet is 36 bits long, MSB first, left aligned. It provides position and two general error warning status bits. All resolutions are available.

### Structure of data packet

Bit	b35 : b10	b9 : b8	b7 : b0
<b>Data length</b>	26 bits	2 bits	8 bits
<b>Meaning</b>	Encoder position	General status	Detailed status

### Encoder position

**b35 : b10** Encoder position, left aligned, MSB first. Unused lower bits are set to 0.  
LSB bit =  $2000 \mu m / 2^{13} = 0.244140625 \mu m$  or  
at 1  $\mu m$  resolution: LSB bit =  $2000 \mu m / 8000 = 0.25 \mu m$

### General status

**b9** Error. If bit is "L", position is not valid.  
**b8** Warning. If bit is "L", encoder is near operational limits. Position is valid.

### Detailed status

**b7** Not used - always 0.  
**b6** Error. If bit is "H" the distance between the readhead and the magnetic scale is too large.  
**b5** Error. If bit is "H" the signal is lost. The readhead is out of alignment with the magnetic scale or the magnetic scale is demagnetised. Incorrect orientation of readhead and magnetic scale.  
**b4** Warning - Temperature. If bit is "H" the readhead temperature is close to operational limits [ $> 80\%$  of maximum temperature].  
**b3** Not used - always 0.  
**b2** Not used - always 0.  
**b1** Not used - always 0.  
**b0** Error - Frequency. If bit is "H" speed of movement is too high.

# SPI - Serial peripheral communication interface (slave mode)

The encoder position, 26 bit natural binary code, and the encoder status are available through the SPI protocol. The position is captured internally every 10  $\mu$ s (refresh rate 100 kHz). Output position data is the last captured data before position request trigger. Request trigger is a falling edge of the CS signal. The position data is left aligned, MSB first. After the position data there are two general status bits (active status low) followed by the detailed status information.

## Electrical connection

Signal	Description
$\overline{CS}$	Active low. $\overline{CS}$ line is used for synchronisation between master and slave devices. During communication it must be held low. Idle is high. Rising edge on $\overline{CS}$ signal resets the SPI interface.
SCK	Clocks out the data on rising edge. Max frequency 4 MHz.
MISO	Data is output on rising edge on SCK after $\overline{CS}$ low. Data is valid on the falling edge of SCK signal. During $\overline{CS}=1$ MISO line is in high-Z mode.

Communication interface variant (part numbering)	Description	Parameter	Value
SP (variant A and C)	SPI slave - simple mode	Resolution	Selectable (see part numbering)
		Status	All status bits are available through the SPI
		Data length	28 bit data packet - position, status
SP (variant B and D)	SPI slave - advanced mode	Resolution	Selectable (see part numbering)
		Status	All status bits are available through the SPI
		Data length	44 bit data packet - position, status, detailed status, CRC

## SPI slave timing diagram

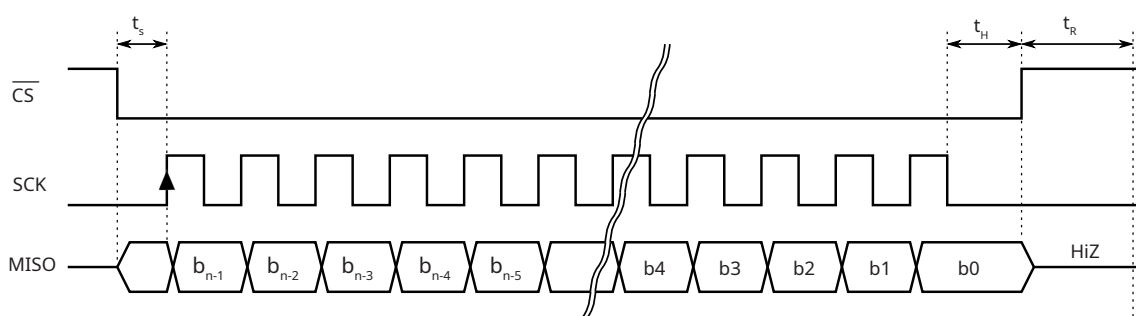

SPI Variant A - Simple mode:  $n = 28$   
 SPI Variant B - Advanced mode:  $n = 44$

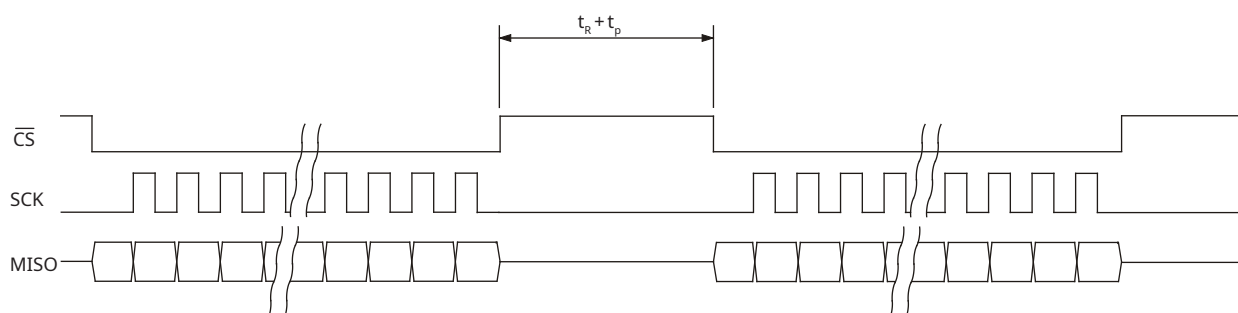

## SPI Parameters

<b>Interface type</b>	SPI unidirectional	
<b>Signal level</b>	3.3 V LVTTTL	
<b>Position data encoding</b>	Pure binary	
<b>CLOCK frequency</b>	<b>Maximum</b>	Up to 4 MHz
	<b>Minimum</b>	50 kHz
<b>Length of position data</b>	26 bits (regardless of the resolution chosen)	
<b>Length and type of status data</b>	2 bits (Error, Warning). Active low. Error/warning descriptions, can be found in the <b>LED Status table</b> .	
<b>Time after last CLK falling edge to CS high <math>t_{\text{H}}</math></b>	>1 $\mu\text{s}$	
<b>Time after CS low to first CLK rising edge <math>t_{\text{S}}</math></b>	>1 $\mu\text{s}$	
<b>CS high time <math>t_{\text{R}}</math> (Time to complete SPI reset)</b>	>1 $\mu\text{s}$	
<b>Max data frame rate</b>	<b>Option A</b>	Simple mode - Position with general status: Up to 90 kHz
	<b>Option B</b>	Advanced mode - Position with general, detailed status and CRC: Up to 60 kHz
<b>Pause time <math>t_{\text{P}}</math></b>	>10 $\mu\text{s}$ (If the reading request arrives earlier than $t_{\text{R}} + t_{\text{P}}$ , the encoder position will not be updated)	

## SPI slave - Simple mode (variant A)

Position is 26 bits long - MSB first, left aligned. After the position data there are two general status bits (active "L").

### Structure of data packet

Bit	b27 : b2	b1 : b0
<b>Data length</b>	26 bits	2 bits
<b>Meaning</b>	Encoder position	General status

### Encoder position

<b>b27 : b2</b>	Encoder position, left aligned, MSB first. Unused lower bits are set to 0. LSB bit = $2000 \mu\text{m} / 2^{13} = \mathbf{0.244140625 \mu\text{m}}$
-----------------	--

### General status

<b>b1</b>	Error. If bit is "L", position is not valid.
<b>b0</b>	Warning. If bit is "L", encoder is near operational limits. Position is valid.

## SPI slave - Advanced mode (variant B)

Position is 26 bits long - MSB first, left aligned. After the position data there are two general status bits (active "L"), 8 bits of detailed status - MSB first and 8 bit of CRC - MSB first.

### Structure of data packet

Bit	b43 : b18	b17 : b16	b15 : b8	b7 : b0
Data length	26 bits	2 bits	8 bits	8 bits
Meaning	Encoder position	General status	Detailed status	CRC

### Encoder position

**b43 : b18** Encoder position, left aligned, MSB first. Unused lower bits are set to 0.  
 LSB bit =  $2000 \mu\text{m} / 2^{13} = \mathbf{0.244140625 \mu\text{m}}$

### General status

**b17** Error. If bit is "L", position is not valid.

**b16** Warning. If bit is "L", encoder is near operational limits. Position is valid.

### Detailed status

**b15** Not used

**b14** Error (if bit is "H") - The distance between the readhead and the magnetic scale is too large.

**b13** Error (if bit is "H") - Signal lost. The readhead is out of alignment with the magnetic scale or the magnetic scale is demagnetised. Incorrect orientation of readhead and magnetic scale.

**b12** Warning (if bit is "H") - Temperature. The readhead temperature is close to operational limits (>80 % of maximum temperature).

**b11** Not used - always 0.

**b10** Not used - always 0.

**b9** Not used - always 0.

**b8** Error (if bit is "H") - Frequency. Speed of movement too high.

### CRC

**b7 : b0** CRC check with polynomial 0x97

# Resolutions and data position alignment

Part number	Resolution
13B	$2/2^{13}$ mm (0.244140625 $\mu$ m)
12B	$2/2^{12}$ mm (0.48828125 $\mu$ m)
11B	$2/2^{11}$ mm (0.9765625 $\mu$ m)
2D0	$2/2000$ mm (1 $\mu$ m)
10B	$2/2^{10}$ mm (1.953125 $\mu$ m)
09B	$2/2^9$ mm (3.90625 $\mu$ m)
08B	$2/2^8$ mm (7.812 $\mu$ m)
07B	$2/2^7$ mm (15.625 $\mu$ m)
06B	$2/2^6$ mm (31.25 $\mu$ m)
05B	$2/2^5$ mm (62.5 $\mu$ m)
04B	$2/2^4$ mm (125 $\mu$ m)

## Table of resolutions and position data length

LA11 always reports the position data in 26 bit binary format. Position data on serial interfaces has fixed length of 26 bits. If selected resolution is less than 13 bits, then unused lower bits are set to 0. Table below shows the bit values in position data for different resolutions.

Resolution	Bits reported position in LA11 output message																										Weight of LSB ( $\mu$ m)	Weight of "last active" bit ( $\mu$ m)
	25	24	23	22	21	20	19	18	17	16	15	14	13	12	11	10	9	8	7	6	5	4	3	2	1	0		
13B	0/1	0/1	0/1	0/1	0/1	0/1	0/1	0/1	0/1	0/1	0/1	0/1	0/1	0/1	0/1	0/1	0/1	0/1	0/1	0/1	0/1	0/1	0/1	0/1	0/1	0/1	0.244140625	0.244140625
12B	0/1	0/1	0/1	0/1	0/1	0/1	0/1	0/1	0/1	0/1	0/1	0/1	0/1	0/1	0/1	0/1	0/1	0/1	0/1	0/1	0/1	0/1	0/1	0/1	0/1	0	0.244140625	0.48828125
11B	0/1	0/1	0/1	0/1	0/1	0/1	0/1	0/1	0/1	0/1	0/1	0/1	0/1	0/1	0/1	0/1	0/1	0/1	0/1	0/1	0/1	0/1	0/1	0/1	0	0	0.244140625	0.9765625
2D0	0/1	0/1	0/1	0/1	0/1	0/1	0/1	0/1	0/1	0/1	0/1	0/1	0/1	0/1	0/1	0/1	0/1	0/1	0/1	0/1	0/1	0/1	0/1	0/1	0	0	0.25	1
10B	0/1	0/1	0/1	0/1	0/1	0/1	0/1	0/1	0/1	0/1	0/1	0/1	0/1	0/1	0/1	0/1	0/1	0/1	0/1	0/1	0/1	0/1	0/1	0/1	0	0	0.244140625	1.953125
09B	0/1	0/1	0/1	0/1	0/1	0/1	0/1	0/1	0/1	0/1	0/1	0/1	0/1	0/1	0/1	0/1	0/1	0/1	0/1	0/1	0/1	0/1	0/1	0	0	0	0.244140625	3.90625
08B	0/1	0/1	0/1	0/1	0/1	0/1	0/1	0/1	0/1	0/1	0/1	0/1	0/1	0/1	0/1	0/1	0/1	0/1	0/1	0/1	0/1	0/1	0	0	0	0	0.244140625	7.8125
07B	0/1	0/1	0/1	0/1	0/1	0/1	0/1	0/1	0/1	0/1	0/1	0/1	0/1	0/1	0/1	0/1	0/1	0/1	0/1	0/1	0/1	0/1	0	0	0	0	0.244140625	15.625
06B	0/1	0/1	0/1	0/1	0/1	0/1	0/1	0/1	0/1	0/1	0/1	0/1	0/1	0/1	0/1	0/1	0/1	0/1	0/1	0/1	0/1	0/1	0	0	0	0	0.244140625	31.25
05B	0/1	0/1	0/1	0/1	0/1	0/1	0/1	0/1	0/1	0/1	0/1	0/1	0/1	0/1	0/1	0/1	0/1	0/1	0/1	0/1	0/1	0/1	0	0	0	0	0.244140625	62.5
04B	0/1	0/1	0/1	0/1	0/1	0/1	0/1	0/1	0/1	0/1	0/1	0/1	0/1	0/1	0/1	0/1	0/1	0/1	0/1	0/1	0/1	0/1	0	0	0	0	0.244140625	125

## Cable length compensation

The readhead needs 70 ns to respond to incoming clocks ( $t_{RESP}$ ). The change on the Data signal is delayed by 70 ns after the rising edge on the Clock line. An additional delay is caused by the time the signal takes to propagate through the cable to the readhead and back ( $t_{PROP}$ ). This delay is typically 14 ns per 1 meter cable. The total cable length from the encoder to the receiver must be considered.

The total delay ( $t_{DELAY}$ ) is calculated as in the formula below.

A proper implementation of BiSS Master should automatically measure  $t_{DELAY}$  and adjust the internal timing to compensate for it.

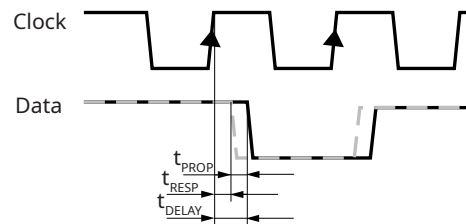

$$t_{DELAY} = t_{RESP} + t_{PROP} \times \text{cable length}$$

## Incremental parallel output

### Incremental output

<b>Output signals</b>	Square-wave signals A, B and their inverted signals A-, B-
<b>Signal level</b>	Differential line driver according to EIA standard RS422
<b>Permissible load</b>	$Z_0 \geq 120 \Omega$ between associated outputs

#### Timing diagram

Complementary signals not shown

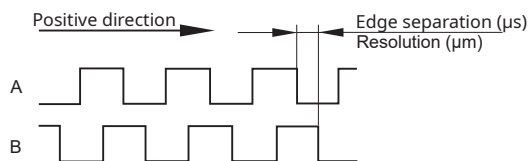

#### Recommended signal termination

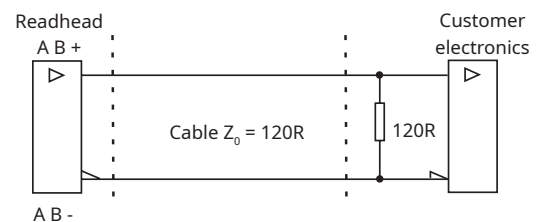

# Part numbering

LA11 SP A 13B K A 10M A 00

## Communication interface

- DI** - BiSS C + Incremental (both RS422)
- SI** - Synchronous serial interface (SSI) + Incremental (both RS422)
- SP** - SPI slave
- SQ** - SPI slave + Incremental, RS422

## Communication interface variant

- For **SI**:  
**A** - Position with general and detailed status
- For **DI**:  
**A** - Up to 2.2 MHz CLK (ACK = 12 clock periods)  
**B** - Up to 3.5 MHz CLK (ACK = 20 clock periods)
- For **SP** and **SQ** (not available with 2D0):  
**A** - Simple mode 3.3 V LVTTTL  
**B** - Advanced mode 3.3 V LVTTTL

## Resolution

- |  |   |   |
|--|---|---|
| <b>13B</b> - 2/2 <sup>13</sup> mm (0.244140625 μm) | <b>10B</b> - 2/2 <sup>10</sup> mm (1.953125 μm) | <b>06B</b> - 2/2 <sup>6</sup> mm (31.25 μm) |
| <b>12B</b> - 2/2 <sup>12</sup> mm (0.48828125 μm)  | <b>09B</b> - 2/2 <sup>9</sup> mm (3.90625 μm)   | <b>05B</b> - 2/2 <sup>5</sup> mm (62.5 μm)  |
| <b>11B</b> - 2/2 <sup>11</sup> mm (0.9765625 μm)   | <b>08B</b> - 2/2 <sup>8</sup> mm (7.812 μm)     | <b>04B</b> - 2/2 <sup>4</sup> mm (125 μm)   |
| <b>2D0</b> - 2/2000 mm (1 μm)*                     | <b>07B</b> - 2/2 <sup>7</sup> mm (15.625 μm)    |   |

\* Available only for SSI and BiSS. Not available for SPI.

## Minimum edge separation

- |  |  |   |
|--|--|---|
| For <b>SP</b> :<br><b>K</b> - N/A  | <b>B</b> - 0.5 μs (2 MHz)<br><b>C</b> - 1 μs (1 MHz)                                 | <b>G</b> - 10 μs (0.1 MHz)<br><b>H</b> - 20 μs (0.05 MHz) |
| For <b>DI</b> , <b>SI</b> and <b>SQ</b> :<br><b>K</b> - 0.07 μs (15 MHz)<br><b>A</b> - 0.12 μs (8 MHz) | <b>D</b> - 2 μs (0.5 MHz)<br><b>E</b> - 4 μs (0.25 MHz)<br><b>F</b> - 5 μs (0.2 MHz) |   |

## Power supply

- A** - 5 V
- B** - From 8 to 30 V (for **DI** and **SI** only)

## Cable length\*\*

- xxD** - Any cable length from 10 dm to 99 dm
- xxM** - Any cable length from 10 m to 30 m

Available lengths for the "W" connector: 1 m, 2 m, 3 m, 4 m, 5 m, 6 m, 7 m, 8 m, 9 m, 10 m, 11 m, 12 m, 13 m, 14 m and 15 m.

\*\* The following lengths are available with short lead times: 1 m, 2 m, 3 m, 4 m, 5 m, 6 m. Please **contact RLS** for lead times for other lengths.

Cable length L [m]	Tolerance [mm]
≤ 2	+30 / -0
2 < L ≤ 7	+40 / -0
10 < L ≤ 15	+50 / -0

## Connector options

- A** - 9 pin D type plug
- D** - 15 pin D type plug
- F** - Flying lead (no connector)
- W** - M12 8 pole over-mould

## Special requirements

- 00** - No special requirements (standard)

Not all combinations are valid. Please check the table of available combinations on the next page.

## Table of available combinations

Series	Communication interface	Commutation interface variant	Resolution	Minimum edge separation	Power supply	Cable length	Connector option	Special requirements
LA11	DI	A / B	13B / 12B / 11B / 2D0 / 10B / 9B / 08B / 07B / 06B / 05B / 04B	K / A / B / C / D / E / F / G / H	A / B	xxD / xxM	D / F	00
	SI	A		K / A / B / C / D / E / F / G / H			D / F	
	SP	A / B	13B / 12B / 11B / 10B / 9B / 08B / 07B / 06B / 05B / 04B	K	A		A / D / F / P / W	
	SQ		K / A / B / C / D / E / F / G / H	D / F				

## Accessories



End clamp kit  
(2 clamps + 2 screws)  
**LM10ECL00**



Applicator tool for magnetic scale  
**LMA10ASC00**

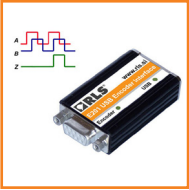

USB interface (for incremental  
output)  
**E201-9Q**



USB interface (for SSI and BiSS  
unidirectional communication interface)  
**E201-9S**



Magnet field viewer  
**MM0001**

## Accessories for MS Track System



Track section, 1.00 m  
**TRS100A00**



Track section, 2.00 m  
**TRS200A00**



Scale clamp, 0.04 m  
**TRE004A00**



Joining element, 0.04 m  
**TRE004A01**



Screw and washer  
**TRC00**

## Head office

---

### RLS Merilna tehnika d.o.o.

Poslovna cona Žeje pri Komendi  
Pod vrbami 2  
SI-1218 Komenda  
Slovenia

**T** +386 1 5272100  
**E** [mail@rls.si](mailto:mail@rls.si)  
[www.rls.si](http://www.rls.si)

## Global support

---

Visit our [website](#) to contact your nearest sales representative.

## Document issues

---

Issue	Date	Page	Description
16	31. 3. 2025	20-21	1 $\mu$ m resolution deleted
17	25. 8. 2025	4	Dimensions drawing amended
18	20. 2. 2026	7, 9, 13	SB, DA, SR, SC, DC communication interfaces and Siemens pinout removed
19	25. 2. 2026	22	Part numbering amended

This product is not designed or intended for use outside the environmental limitations and operating parameters expressly stated on the product's datasheet. Products are not designed or intended for use in medical, military, aerospace, automotive or oil & gas applications or any safety-critical applications where a failure of the product could cause severe environmental or property damage, personal injury or death. Any use in such applications must be specifically agreed to by seller in writing, and is subject to such additional terms as the seller may impose in its sole discretion. Use of products in such applications is at buyer's own risk, and buyer will indemnify and hold harmless seller and its affiliates against any liability, loss, damage or expense arising from such use. Information contained in this datasheet was derived from product testing under controlled laboratory conditions and data reported thereon is subject to the stated tolerances and variations, or if none are stated, then to tolerances and variations consistent with usual trade practices and testing methods. The product's performance outside of laboratory conditions, including when one or more operating parameters is at its maximum range, may not conform to the product's datasheet. Further, information in the product's datasheet does not reflect the performance of the product in any application, end-use or operating environment buyer or its customer may put the product to. Seller and its affiliates make no recommendation, warranty or representation as to the suitability of the product for buyer's application, use, end-product, process or combination with any other product or as to any results buyer or its customer might obtain in their use of the product. Buyer should use its own knowledge, judgment, expertise and testing in selecting the product for buyer's application, end-use and/or operating environment, and should not rely on any oral or written statement, representation, or samples made by seller or its affiliates for any purpose. EXCEPT FOR THE WARRANTIES EXPRESSLY SET FORTH IN THE SELLER'S TERMS AND CONDITIONS OF SALE, SELLER MAKES NO WARRANTY EXPRESS OR IMPLIED WITH RESPECT TO THE PRODUCT, INCLUDING ANY WARRANTY OF MERCHANTABILITY OR FITNESS FOR ANY PARTICULAR PURPOSE, WHICH ARE DISCLAIMED AND EXCLUDED. All sales are subject to seller's exclusive terms and conditions of sale which, where the seller is (a) RLS Merilna tehnika d. o. o., are available at [www.rls.si/customer-service](http://www.rls.si/customer-service), (b) Renishaw, Inc., are available at [www.renishaw.com/Shop/legal/en/-42186](http://www.renishaw.com/Shop/legal/en/-42186), or (c) another person, are available on request, and in each case, are incorporated herein by reference, and are the exclusive terms of sale. No other terms and conditions apply. Buyer is not authorized to make any statements or representations that expand upon or extend the environmental limitations and operating parameters of the products, or which imply permitted usage outside of that expressly stated on the datasheet or agreed to in writing by seller.

RLS Merilna tehnika d. o. o. has made considerable effort to ensure the content of this document is correct at the date of publication but makes no warranties or representations regarding the content. RLS Merilna tehnika d. o. o. excludes liability, howsoever arising, for any inaccuracies in this document. © 2026 RLS d. o. o.