

# LM10ECL00 end clamp kit installation

The LM10ECL00 end clamp kit has been designed to anchor the ends of the MS magnetic scale.  
 Included in the kit are 2 end clamps and 2 screws M2.5 × 6 DIN 965.

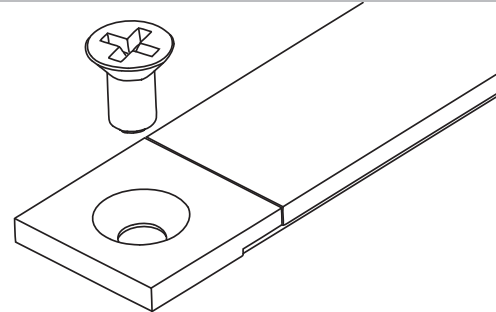

## Installation process

### 1 Prepare the mounting surface

- Drill the holes to the mounting surface according to Figure 1

Figure 1

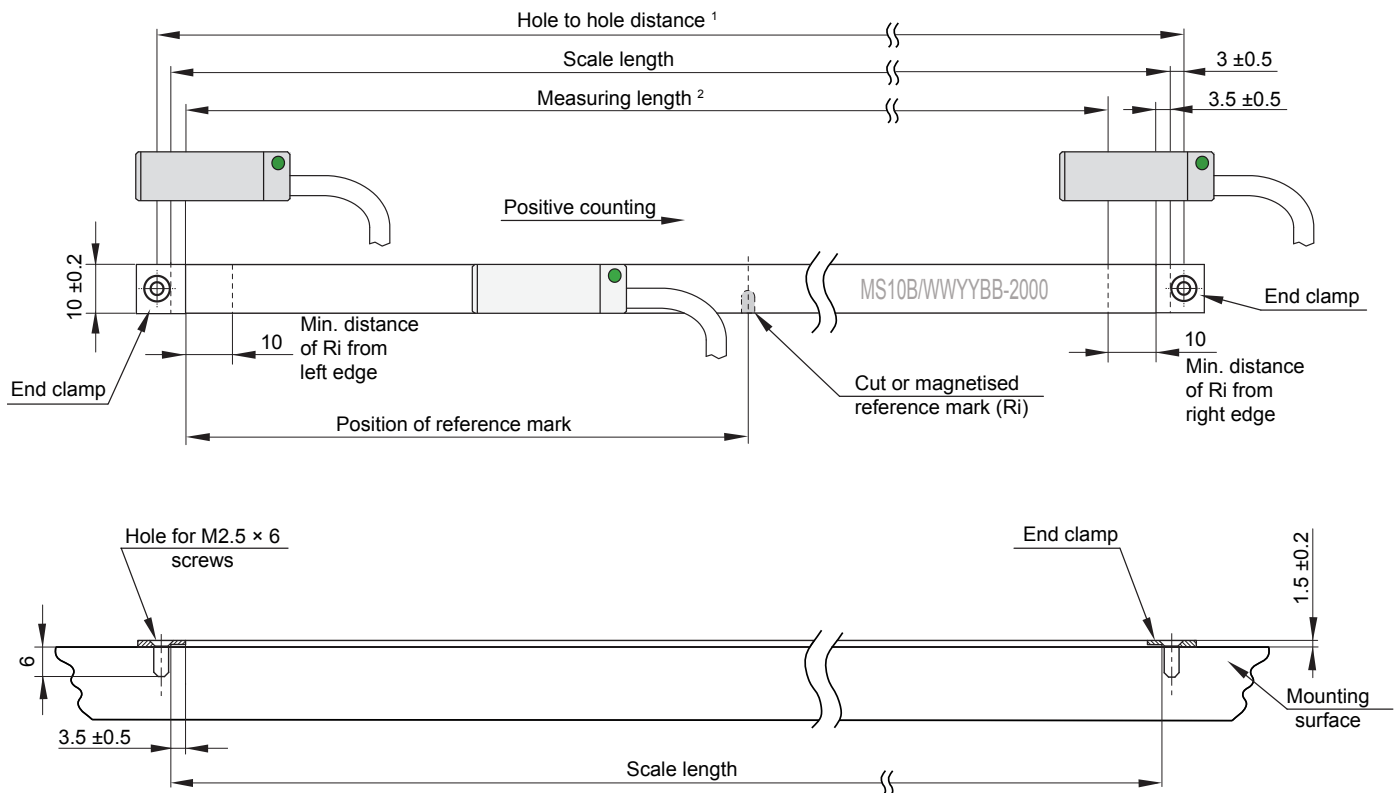

<sup>1</sup> Hole to hole distance = scale length + 6 ± 1 mm

<sup>2</sup> Measuring length = scale length - 17 mm

## 2 Prepare the magnetic scale

- If the scale has not been ordered prepared for installation with end clamps, please ensure:
  - the hole to hole distance is correct: scale length + 6 mm,
  - the rubber surface on the scale ends has been cut and removed according to Figure 2.

Figure 2

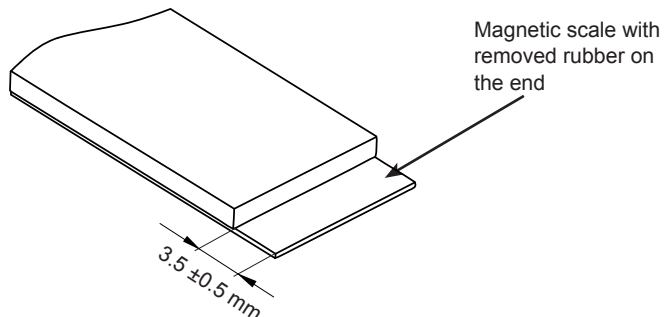

## 3 Install the scale to the surface

- Ensure scale is cut to correct length and mounting surface has been cleaned. Install the self adhesive backed scale using the scale applicator tool.

## 4 Install the end clamps

- Use enclosed screws and screw the end clamps ensuring the magnetic scale is held under the clamp (see Figure 3).

Figure 3

