

# RM36 rotary magnetic encoder



**The RM36 is a high-speed magnetic rotary encoder designed for use in harsh industrial environments. The non-contact two-part design removes the need for seals or bearings ensuring long-term reliability and simple installation.**

**The encoder comprises a magnetic actuator and a separate encoder body. Rotation of the magnetic actuator is sensed by a custom encoder chip within the body, and processed to the required output.**

The encoder chip processes the signals received to provide resolutions to 13 bit (8,192 positions per revolution) with high operational speeds. Resolution options include binary and decimal. Output signals are provided in industry standard absolute, incremental or linear formats.

The compact encoder body is 36 mm in diameter and provides dirt immunity up to IP68.

The RM36 can be used in a wide range of applications including marine, medical, print, converting, industrial automation, metal working, motor control and instrumentation.

## Product range

### 5 V power supply version

#### RM36IC

Incremental with 80 to 2,048 pulses per revolution (320 to 8,192 counts per revolution with x 4 evaluation)

#### RM36S

Synchro serial interface (SSI) with 320 to 8,192 positions per revolution

### 24 V power supply version

#### RM36I

Incremental with 80 to 2,048 pulses per revolution (320 to 8,192 counts per revolution with x 4 evaluation)

#### RM36Vx

Linear voltage output in a range of variants

#### RM36Cx

Linear current output in a range of variants

- Excellent immunity to IP68
- Non-contact, frictionless design
- High speed operation to 30,000 rpm
- 36 mm diameter body
- Accuracy  $\pm 0.5^\circ$
- Simple installation
- Low inertia
- Stainless steel body option
- CE compliant, including RoHS - see Declaration of conformity

## Storage and handling

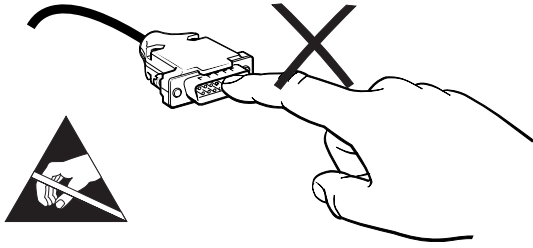

**IMPORTANT:** Power to RM36 encoders must be supplied from a DC SELV supply complying with the essential requirements of EN (IEC) 60950 or similar specification.

The RM36 series encoders have been designed to the relevant EMC standards, but must be correctly integrated to achieve EMC compliance. In particular, attention to shielding arrangements is critical.

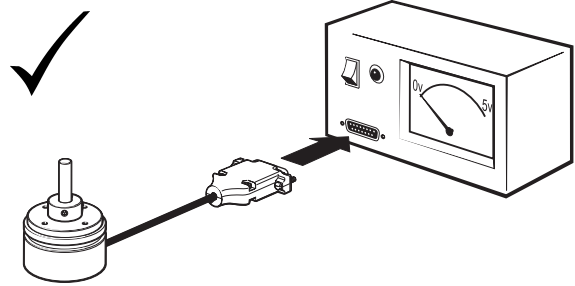
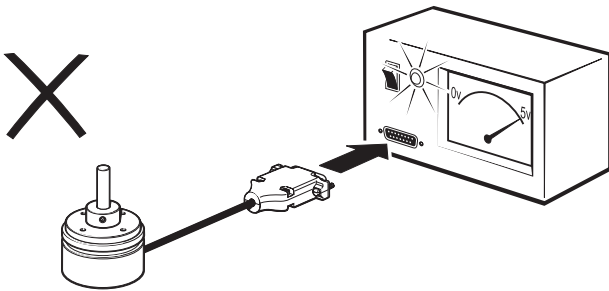

## Connections

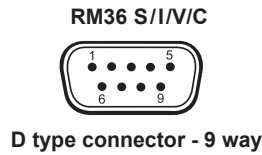
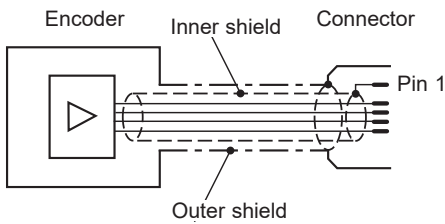

Pin Nr.	RM36SC		RM36bx		RM36Vx		RM36Cx		RM36SI	
	Function	Wire colour	Function	Wire colour	Function	Wire colour	Function	Wire colour	Function	Wire colour
1	Shield - see connection diagram		Shield - see connection diagram		Shield - see connection diagram		Shield - see connection diagram			
2	Clock	White	Z	White	NC	-	NC	-	A+	Gray
3	Clock-	Brown	B	Green	$V_{out}$	Green	$I_{out}$	Green	A-	Pink
4	NC	-	A+	Grey	NC	-	NC	-	B+	Green
5	$V_{dd}$	Red	$V_{dd}$	Red	$V_{dd}^+$	Red	$V_{dd}$	Red	B-	Yellow
6	Data	Green	$Z^{-1}$	Brown	$V_{dd}^{-2}$	Brown	NC	-	Ri+	White
7	Data-	Yellow	$B^{-1}$	Yellow	NC	-	NC	-	Ri-	Brown
8	NC	-	$A^{-1}$	Pink	NC	-	NC	-	$V_{dd}$	Red
9	GND	Blue	GND	Blue	0 V	Blue	0 V	Blue	Clock+	Black
10									Clock-	Violet
11									NC	-
12									Data+	Orange
13									Data-	Clear
14									NC	-
15									GND	Blue

<sup>1</sup> Not available for IB variant

<sup>2</sup> For variants VM, VN, VP, VQ, VR, VS, VT, and VV only

## Dimensions

Dimensions and tolerances in mm

### Encoder body

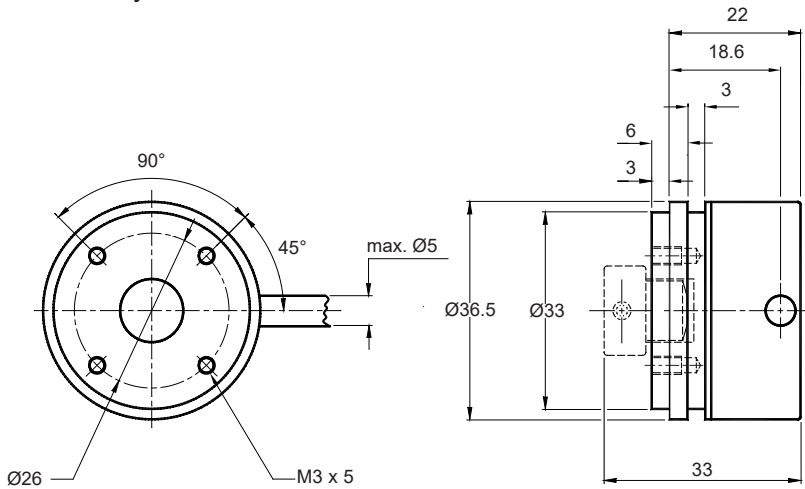

### Magnetic actuator

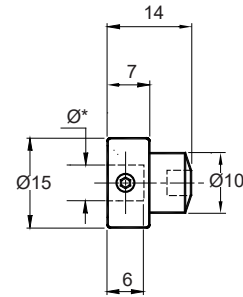

\* Hole diameter for nominal shaft size.

## Installation drawing

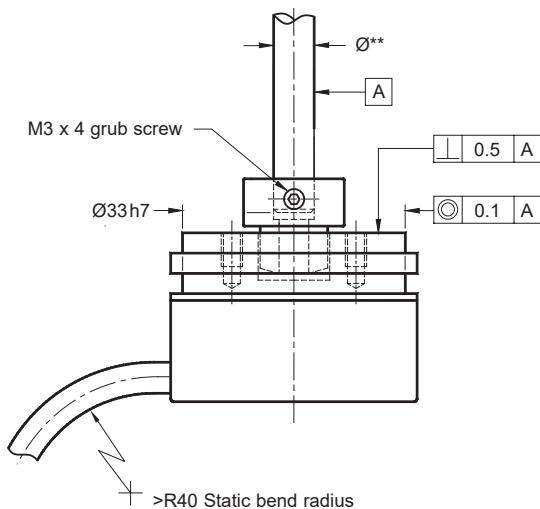

\*\*Nominal shaft size with tolerance h7.

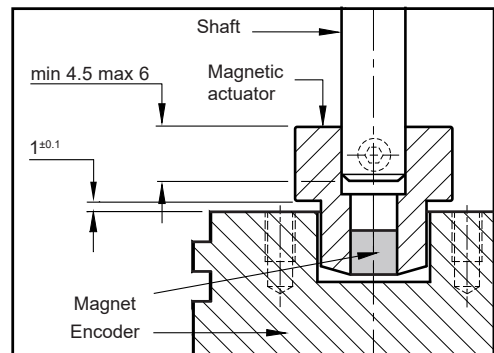

Clockwise (CW) rotation of magnetic actuator.



## Operating and electrical specifications

<b>Humidity</b> (for IP64 version)	Storage 95 % maximum relative humidity (non-condensing) (IEC 61010-1) Operating 80 % maximum relative humidity (non-condensing) (IEC 61010-1)
<b>Acceleration</b>	Operating 500 m/s <sup>2</sup> EN 60068-2-7:1993 (IEC 68-2-7:1983)
<b>Shock (non-operating)</b>	1000 m/s <sup>2</sup> , 6 ms, 1/2 sine EN 60068-2-27:1993 (IEC 68-2-27:1987)
<b>Vibration (operating)</b>	100 m/s <sup>2</sup> max at 55 to 2000 Hz EN 60068-2-6:1996 (IEC 68-2-6:1995)
<b>EMC compliance</b>	EN 61326
<b>Cable</b>	Outside diameter max. 5 mm, $>R40$ static bend radius
<b>Mass</b>	Encoder unit 1 m cable (no connector) 85 g. Stainless steel variant 160 g. Magnetic actuator 12 g
<b>Environmental sealing</b>	IP64 (IP68 optional) EN 60529

## Output specifications - 5 V supply

### RM36IC – Incremental, RS422

Square wave differential line driver to RS422

<b>Power supply</b>	$V_{dd} = 5\text{ V} \pm 5\%$
<b>Power consumption</b>	Max. 35 mA
<b>Output signals</b>	A, B, Z, A-, B-, Z- (RS422)
<b>Accuracy</b>	Typ. $\pm 0.5^\circ$
<b>Hysteresis</b>	$0.18^\circ$
<b>Resolution</b>	80 to 2,048 pulses per revolution (320, 400, 500, 512, 800, 1,000, 1,024, 1,600, 2,000, 2,048, 4,096, 8,192 counts per revolution)
<b>Maximum speed</b>	30,000 rpm
<b>Maximum cable length</b>	50 m
<b>Operating temperature</b>	$-40\text{ }^\circ\text{C}$ to $+125\text{ }^\circ\text{C}$ (IP64) $-40\text{ }^\circ\text{C}$ to $+85\text{ }^\circ\text{C}$ (IP68)

### Timing diagram

Complementary signals not shown

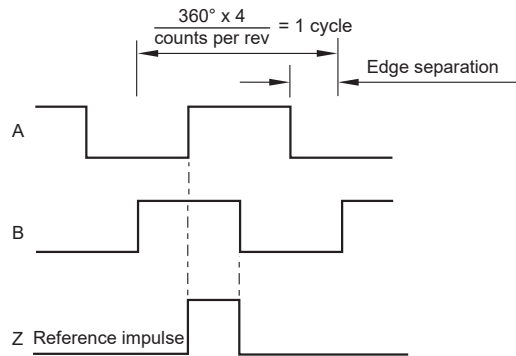

B leads A for clockwise rotation of magnetic actuator.

### Recommended signal termination

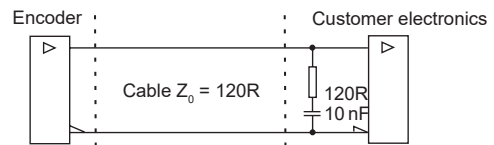

### RM36SC – Absolute binary synchro-serial interface (SSI)

Serial encoded absolute position measurement

<b>Output code</b>	Natural binary
<b>Power supply</b>	$V_{dd} = 5\text{ V} \pm 5\%$
<b>Power consumption</b>	Max. 35 mA
<b>Data output</b>	Serial data (RS422)
<b>Data input</b>	Clock (RS422)
<b>Accuracy</b>	Typ. $\pm 0.5^\circ$
<b>Hysteresis</b>	$0.18^\circ$
<b>Resolution</b>	320, 400, 500, 512, 800, 1,000, 1,024, 1,600, 2,000, 2,048, 4,096, 8,192 positions per revolution
<b>Maximum speed</b>	30,000 rpm
<b>Maximum cable length</b>	100 m (at 1 MHz)
<b>Operating temperature</b>	$-40\text{ }^\circ\text{C}$ to $+125\text{ }^\circ\text{C}$ (IP64) $-40\text{ }^\circ\text{C}$ to $+85\text{ }^\circ\text{C}$ (IP68)

### Timing diagram

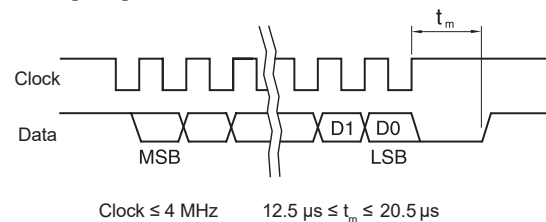

Position increases for clockwise rotation of magnetic actuator.

### Recommended signal termination

For data output lines only

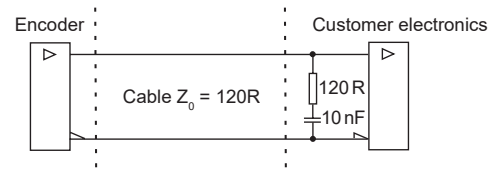

## RM36SI – Absolute binary synchro-serial (SSI) + Incremental, RS422

Complex feedback device for absolute position at start up as well as during operation + incremental outputs.  
Both the incremental and the SSI output always have the same fixed resolution.

<b>Output code</b>	Natural binary
<b>Power supply</b>	$V_{dd} = 5\text{ V} \pm 5\%$
<b>Power consumption</b>	Max. 35 mA
<b>Incremental outputs</b>	A, B, Z, A-, B-, Z- (RS422)
<b>Data output</b>	Serial data (RS422)
<b>Data input</b>	Clock (RS422)
<b>Accuracy</b>	Typ. $\pm 0.5^\circ$
<b>Hysteresis</b>	$0.18^\circ$
<b>Resolution</b>	80 to 2,048 pulses per revolution (320, 400, 500, 512, 800, 1,000, 1,024, 1,600, 2,000, 2,048, 4,096, 8,192 counts per revolution)
<b>Maximum speed</b>	30,000 rpm
<b>Maximum cable length</b>	50 m
<b>Operating temperature</b>	$-40^\circ\text{C}$ to $+125^\circ\text{C}$ (IP64) $-40^\circ\text{C}$ to $+85^\circ\text{C}$ (IP68)

### Recommended signal termination

For incremental signals + SSI data output lines only

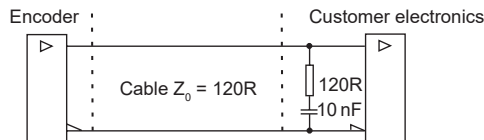

### Timing diagram - SSI

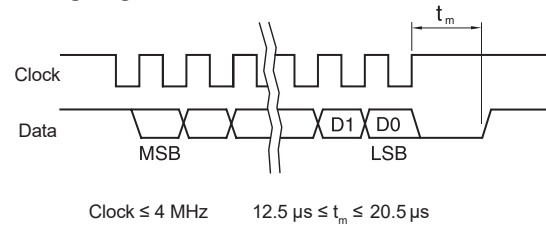

Position increases for clockwise rotation of magnetic actuator.

### Timing diagram - Incremental

Complementary signals not shown

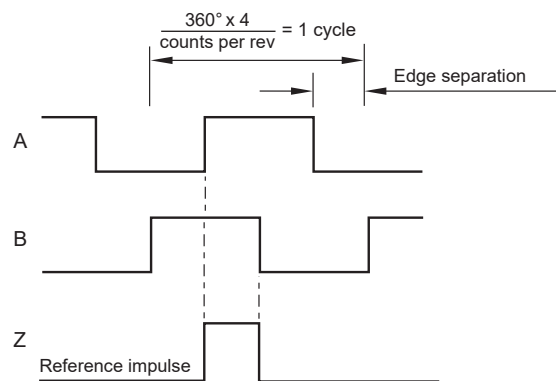

B leads A for clockwise rotation of magnetic actuator.

**Output specifications - 24 V supply**

**RM36IA – Incremental, push-pull**

<b>Power supply</b>	$V_{dd} = 8 \text{ V to } 26 \text{ V}$
<b>Power consumption</b>	50 mA
<b>Output signals</b>	A, B, Z, A-, B-, Z- (RS422)
<b>Maximum output load</b>	30 mA
<b>Accuracy</b>	Typ. $\pm 0.5^\circ$
<b>Hysteresis</b>	$0.18^\circ$
<b>Resolution</b>	80 to 2,048 pulses per revolution (320, 400, 500, 512, 800, 1,000, 1,024, 1,600, 2,000, 2,048, 4,096, 8,192 counts per revolution)
<b>Maximum speed</b>	30,000 rpm
<b>Maximum cable length</b>	20 m
<b>Operating temperature</b>	$-40^\circ \text{ C to } +125^\circ \text{ C}$ (IP64) $-40^\circ \text{ C to } +85^\circ \text{ C}$ (IP68)

**Timing diagram**

Complementary signals not shown

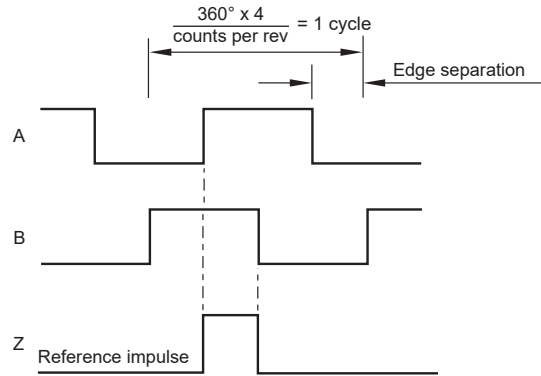

B leads A for clockwise rotation of magnetic actuator.

**RM36IB – Incremental, open collector NPN**

Square wave output

<b>Power supply</b>	$V_{dd} = 8 \text{ V to } 26 \text{ V}$
<b>Power consumption</b>	50 mA
<b>Output signals</b>	A, B, Z
<b>Maximum output load</b>	20 mA
<b>Accuracy</b>	Typ. $\pm 0.5^\circ$
<b>Hysteresis</b>	$0.18^\circ$
<b>Resolution</b>	80 to 2,048 pulses per revolution (320, 400, 500, 512, 800, 1,000, 1,024, 1,600, 2,000, 2,048, 4,096, 8,192 counts per revolution)
<b>Maximum speed</b>	30,000 rpm
<b>Maximum cable length</b>	20 m
<b>Operating temperature</b>	$-40^\circ \text{ C to } +125^\circ \text{ C}$ (IP64) $-40^\circ \text{ C to } +85^\circ \text{ C}$ (IP68)

**Timing diagram**

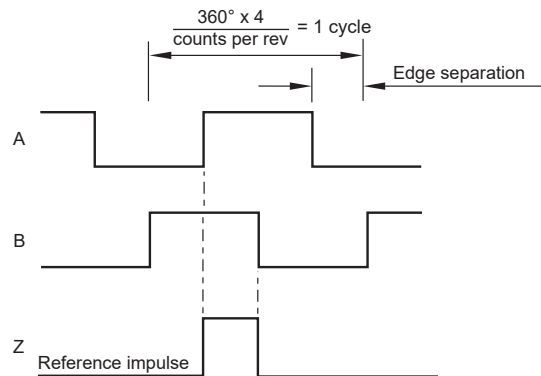

**Recommended signal termination**

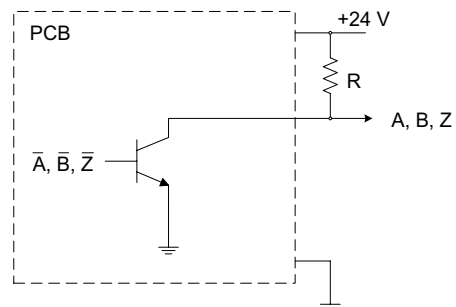

### RM36Vx – Linear voltage output

<b>Power supply</b>	Type I: +20 V to +30 V DC Type II: ±12 V to ±16 V DC
<b>Power consumption</b>	Typ. 40 mA
<b>Output voltage</b>	Type I: 0 V to 10 V DC Type II: –10 V to +10 V DC
<b>Output loading</b>	Max. 10 mA
<b>Nonlinearity</b>	1 %
<b>Maximum speed</b>	30,000 rpm
<b>Maximum cable length</b>	20 m
<b>Operating and storage temperature</b>	–25 °C to +85°C

Electrical output/shaft position

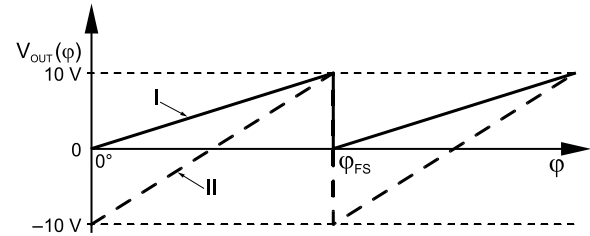

### Output type and electrical variant

$\Phi_{FS}$	Type I				Type II			
	360°	180°	90°	45°	360°	180°	90°	45°
CW	VA	VB	VC	VD	VM	VN	VP	VQ
CCW	VE	VF	VG	VH	VR	VS	VT	VV

### RM36Cx - Linear current output

<b>Power supply</b>	$V_{dd} = +20 \text{ V to } +30 \text{ V DC}$
<b>Power consumption</b>	50 mA plus output current
<b>Output current</b>	4 mA to 20 mA
<b>Output loading</b>	$R_L = 0 \text{ to } \frac{V_{dd}}{I_{OUTmax}}$
<b>Nonlinearity</b>	1 %
<b>Maximum speed</b>	30,000 rpm
<b>Maximum cable length</b>	20 m
<b>Operating and storage temperature</b>	–25 °C to +85°C

Electrical output/shaft position

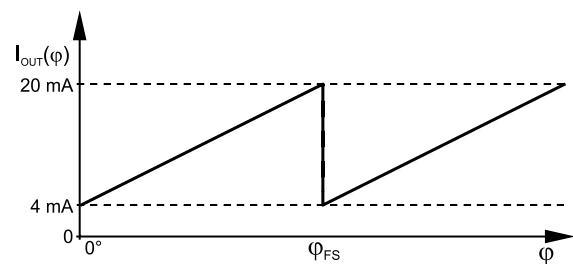

### Output type and electrical variant

$\Phi_{FS}$	360°	180°	90°	45°
CW	CA	CB	CC	CD
CCW	CE	CF	CG	CH

**Part numbering**

Encoder system = Encoder body + Magnetic actuator



**RM36 SC 00 12B 10 A 2 B 00**

**Output type**

- IA** - Incremental, push-pull, 24 V
- IB** - Incremental, open collector, 24 V
- IC** - Incremental, RS422, 5 V
- SC** - Absolute binary synchro-serial (SSI), RS422, 5 V
- SI** - SSI + Incremental, RS422, 5 V
- Cx** - Linear current:

Linear current output 4 - 20 mA, supply +20 V to +30 V DC				
	360°	180°	90°	45°
CW	<b>CA</b>	<b>CB</b>	<b>CC</b>	<b>CD</b>
CCW	<b>CE</b>	<b>CF</b>	<b>CG</b>	<b>CH</b>

**Vx** - Linear voltage:

Linear voltage output 0 - 10 V, supply +20 V to +30 V DC				
	360°	180°	90°	45°
CW	<b>VA</b>	<b>VB</b>	<b>VC</b>	<b>VD</b>
CCW	<b>VE</b>	<b>VF</b>	<b>VG</b>	<b>VH</b>
Linear voltage output ±10 V, supply ±12 V to ±16 V DC				
	360°	180°	90°	45°
CW	<b>VM</b>	<b>VN</b>	<b>VP</b>	<b>VQ</b>
CCW	<b>VR</b>	<b>VS</b>	<b>VT</b>	<b>VV</b>

**Shaft size**  
 00 - N/A

**Special requirements**

- 00** - No special requirements (standard)
- 0M** - Cable length in meters

**Environment and material**

- B** - IP64, aluminium body, high EMC grade (standard)
- C** - IP68, aluminium body, high EMC grade
- J** - IP68, stainless steel body, high EMC grade

**Body style and cable exit**

- 2** - Cylindrical body, radial cable exit

**Connector option**

- A** - 'D' type connector - 9 way (for **IA**, **IB**, **IC**, **SC**, **Cx**, **Vx** only)
- B** - 'D' type connector - 15 way (for **SI** only)
- F** - Flying lead (no connector)

**Cable length**

- 10** - 1.0 meter (or 10 meters if **0M** special requirement is chosen)

**Resolution**

For **IA**, **IB**, **IC**, **SC** and **SI** (counts/positions per revolution):

Decimal			Binary	
<b>D32</b> - 320	<b>D80</b> - 800	<b>2D0</b> - 2000	<b>09B</b> - 512	<b>12B</b> - 4096
<b>D40</b> - 400	<b>1D0</b> - 1000		<b>10B</b> - 1024	<b>13B</b> - 8192
<b>D50</b> - 500	<b>1D6</b> - 1600		<b>11B</b> - 2048	

**NOTE:** Not all combinations are valid.

For **Cx** and **Vx**:

**10B** - 1,024 positions per revolution

**Magnetic actuator ordering information**

**Actuator for integration onto shaft**



Shaft = Ø\*h7  
 Fixing: Grub screw provided

**Part numbers:**

For resolutions of 9 bit absolute (512 cpr incremental)

- RMA04A2A00** - 4 mm dia shaft
- RMA05A2A00** - 5 mm dia shaft
- RMA06A2A00** - 6 mm dia shaft
- RMA08A2A00** - 8 mm dia shaft
- RMA10A2A00** - 10 mm dia shaft
- RMA19A2A00** - 3/16" dia shaft
- RMA25A2A00** - 1/4" dia shaft
- RMA37A2A00** - 3/8" dia shaft

For resolutions from 10 bit absolute (800 cpr incremental) and above

- RMA04A3A00** - 4 mm dia shaft
- RMA05A3A00** - 5 mm dia shaft
- RMA06A3A00** - 6 mm dia shaft
- RMA08A3A00** - 8 mm dia shaft
- RMA10A3A00** - 10 mm dia shaft
- RMA19A3A00** - 3/16" dia shaft
- RMA25A3A00** - 1/4" dia shaft
- RMA37A3A00** - 3/8" dia shaft

## Head office

---

### RLS merilna tehnika d.o.o.

Poslovna cona Žeje pri Komendi  
Pod vrbami 2  
SI-1218 Komenda  
Slovenia

**T** +386 1 5272100

**F** +386 1 5272129

**E** [mail@rls.si](mailto:mail@rls.si)

**www.rls.si**

## Document issues

Issue	Date	Page	Corrections made
3	18. 5. 2018	4 - 6	Resolutions amended
4	04. 07. 2018	General	All outputs amended
5	15. 12. 2025	3	Cable diameter amended

This product is not designed or intended for use outside the environmental limitations and operating parameters expressly stated on the product's datasheet. Products are not designed or intended for use in medical, military, aerospace, automotive or oil & gas applications or any safety-critical applications where a failure of the product could cause severe environmental or property damage, personal injury or death. Any use in such applications must be specifically agreed to by seller in writing, and is subject to such additional terms as the seller may impose in its sole discretion. Use of products in such applications is at buyer's own risk, and buyer will indemnify and hold harmless seller and its affiliates against any liability, loss, damage or expense arising from such use. Information contained in this datasheet was derived from product testing under controlled laboratory conditions and data reported thereon is subject to the stated tolerances and variations, or if none are stated, then to tolerances and variations consistent with usual trade practices and testing methods. The product's performance outside of laboratory conditions, including when one or more operating parameters is at its maximum range, may not conform to the product's datasheet. Further, information in the product's datasheet does not reflect the performance of the product in any application, end-use or operating environment buyer or its customer may put the product to. Seller and its affiliates make no recommendation, warranty or representation as to the suitability of the product for buyer's application, use, end-product, process or combination with any other product or as to any results buyer or its customer might obtain in their use of the product. Buyer should use its own knowledge, judgment, expertise and testing in selecting the product for buyer's application, end-use and/or operating environment, and should not rely on any oral or written statement, representation, or samples made by seller or its affiliates for any purpose. EXCEPT FOR THE WARRANTIES EXPRESSLY SET FORTH IN THE SELLER'S TERMS AND CONDITIONS OF SALE, SELLER MAKES NO WARRANTY EXPRESS OR IMPLIED WITH RESPECT TO THE PRODUCT, INCLUDING ANY WARRANTY OF MERCHANTABILITY OR FITNESS FOR ANY PARTICULAR PURPOSE, WHICH ARE DISCLAIMED AND EXCLUDED. All sales are subject to seller's exclusive terms and conditions of sale which, where the seller is (a) RLS merilna tehnika d.o.o., are available at <https://www.rls.si/customer-service>, (b) Renishaw, Inc., are available at <http://www.renishaw.com/Shop/legal/en/-42186>, or (c) another person, are available on request, and in each case, are incorporated herein by reference, and are the exclusive terms of sale. No other terms and conditions apply. Buyer is not authorized to make any statements or representations that expand upon or extend the environmental limitations and operating parameters of the products, or which imply permitted usage outside of that expressly stated on the datasheet or agreed to in writing by seller.

RLS merilna tehnika d.o.o. has made considerable effort to ensure the content of this document is correct at the date of publication but makes no warranties or representations regarding the content. RLS merilna tehnika d.o.o. excludes liability, howsoever arising, for any inaccuracies in this document. © 2025 RLS d.o.o.