

RLC2IA

Miniature Incremental Magnetic Encoder Module

SMALL SIZE
& SIMPLE
INTEGRATION

UNIQUE
REFERENCE
MARK

24 V POWER
SUPPLY

RLC2IA is a PCB-level encoder with a 24 V incremental push-pull output signal. The encoder system consists of a PCB sensor and a magnetic scale or ring.

It is designed for embedded motion control applications as a position control loop element in applications with limited space. It guarantees a highly repeatable position measurement under wide mounting tolerances and temperature ranges.

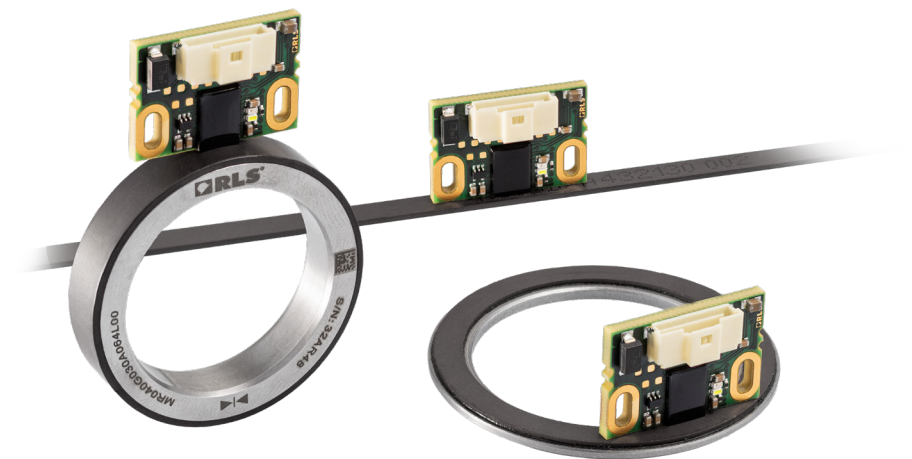

Features and benefits

- ▶ Incremental push-pull output (24 V)
- ▶ Unique or periodic bidirectional reference mark
- ▶ High system accuracy up to $\pm 10 \mu\text{m}$
- ▶ High threshold logic (HTL)
- ▶ For use with scales, radial and axial rings
- ▶ Non-contact and wear-free measuring principle
- ▶ Miniature design
- ▶ Status indicator LED



ELECTRIC MOTORS



PRINTING TECHNOLOGY



ASSEMBLY LINES



SMT PICK AND PLACE



ROBOTIC JOINTS

General information

The RLC2IA is a small PCB-level encoder with 24 V incremental push-pull signals and the possibility of a reference signal. The encoder is fitted with Molex 5015681107 connector and is very suitable for applications with limited space.

Choose your RLC2IA system

The radial magnetic ring is designed for high-precision rotational measurement. Robust mechanical integration ensures stable performance in demanding applications. Optional stainless steel cover provides additional environmental protection.

The axial magnetic ring is optimised for configurations with compact installation requirements. It enables reliable rotational feedback in space-constrained designs.

The incremental magnetic scale MS05 with selectable lengths up to 50 m is suitable for long linear measurements while maintaining high signal stability. Optional reference marks enable precise and repeatable positioning.

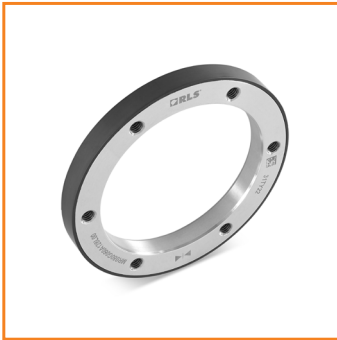

Radial magnetic ring



Axial magnetic ring



Magnetic scale

Further information

For detailed documentation, including compatible scales (MSD01), radial (MR02D02) and axial rings (MR01D01), data sheets and 3D models, refer to the [RLC2IA](#) product page or [RLS Media center](#).

Storage and handling

Storage and operating temperature



-40 °C to +105 °C

Humidity



Up to 70 % non-condensing

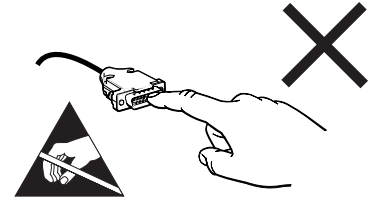
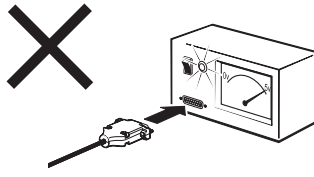
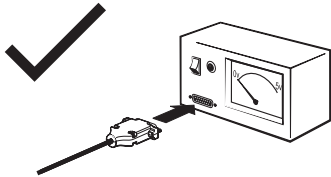

The encoder is a mechanically sensitive component. Handle it by its edges, touch it lightly, minimize pressure and eliminate bending while maintaining a secure grip to prevent falls. Maximize cleanliness. When it's not in use, place it in an ESD protective packaging (box or tray).

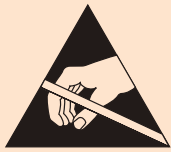

Readhead is ESD sensitive - handle with care.

Do not touch electronic circuit, wires or sensor area without proper ESD protection or outside of ESD controlled environment.

Further information

For detailed documentation, including compatible scales (MSD01), radial (MR02D02) and axial rings (MR01D01), data sheets and 3D models, refer to the [RLC2IA](#) product page or [RLS Media center](#).

Operational conditions

The magnetic encoder system must be used in accordance with the specified degree of protection. The following factors must be taken into account: IP protection class, operating temperature, external magnetic field, humidity level, mechanical load and EMC compatibility.

External magnetic fields

The magnetic encoder system is sensitive to the external magnetic fields. The magnitude of the influence on the magnetic encoder system depends on the magnitude and direction of the external magnetic field. In particular, the rapidly changing stray magnetic fields affect the encoder system and can alter its function. Magnetic field strength within 1 mT reduces the accuracy of the system. Field strengths greater than 1 mT will cause the system to malfunction and as a result the readhead will report an incorrect absolute position with the error status active.

Magnetic field strengths of more than 25 mT cause irreversible damage to the magnetic scale and must be replaced.

Product identification and markings

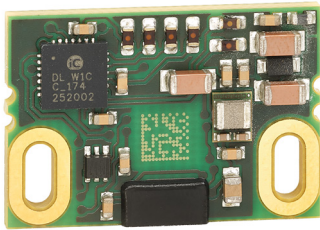

The marking on the label contains an alphanumeric serial number and a QR code containing the serial number.

Dimension drawings

Dimensions and tolerances are in mm. Dimensions without tolerance values are in accordance with ISO 2768-m.

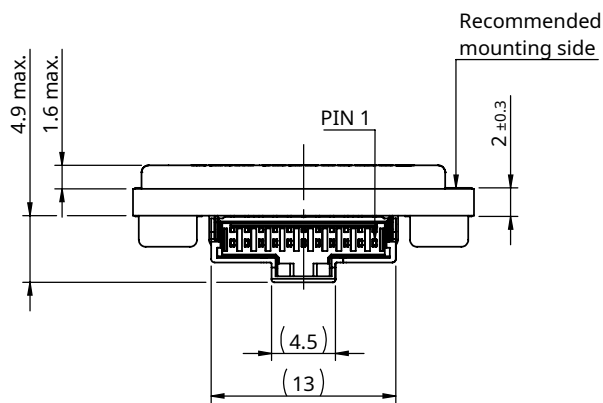
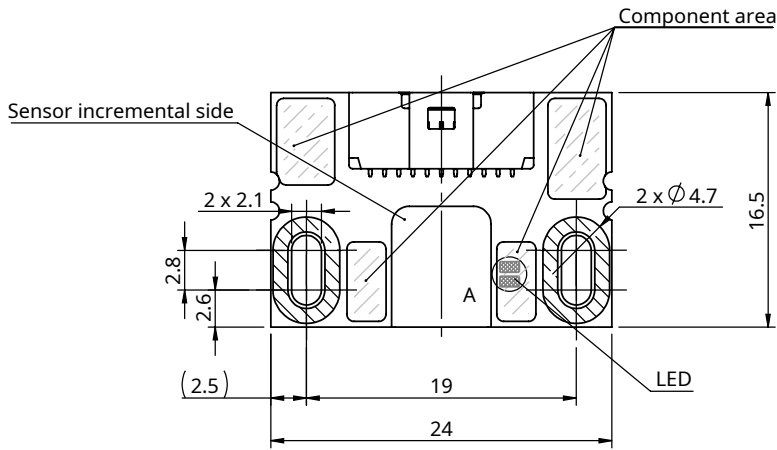

3D models are available on the [RLC2IA product page](#) and in the [RLS Media center](#).

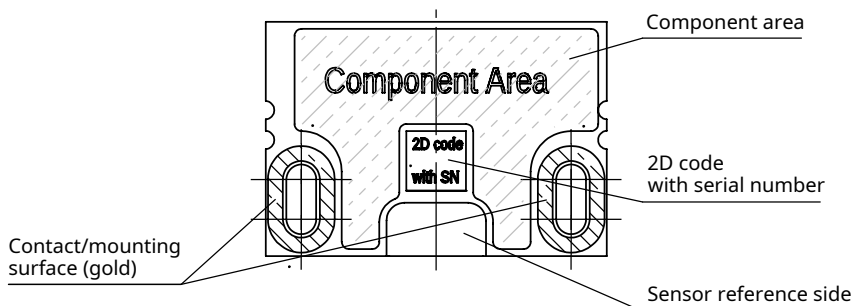

Further information

For detailed documentation, including compatible scales (MSD01), radial (MR02D02) and axial rings (MR01D01) and data sheets, refer to the [RLC2IA product page](#) or [RLS Media center](#).

Installation instructions

When mounting the RLC2IA, make sure that only the mounting surfaces of the PCB assembly are in contact with the mounting bracket. All other parts of the PCB assembly should maintain a minimum distance of 0.1 mm from other metal objects. It is important that the space between the readhead and the magnetic scale is maintained over the entire measuring range. All permissible distance and angle tolerances must be strictly complied according to the mounting instructions found at MSD01, MR01D01 or MR02D02 data sheets at [RLS Media center](#).

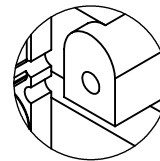
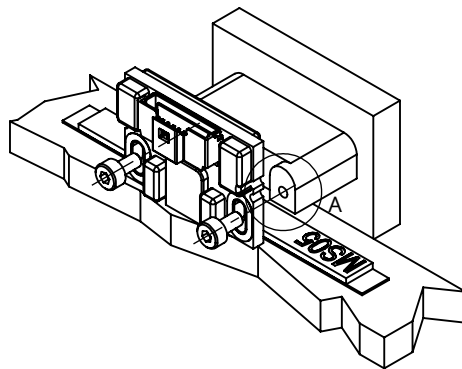
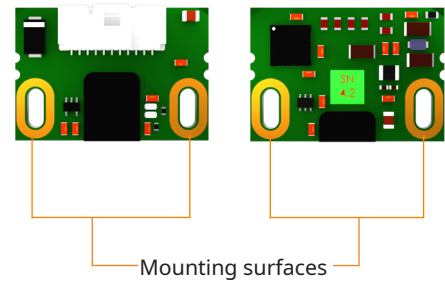
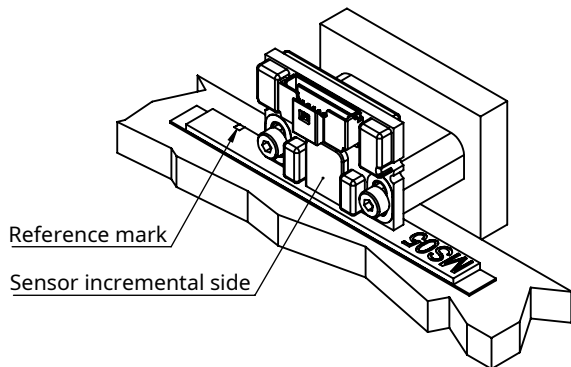

A (2 : 1)

Images are for illustration purpose only. Valid for all versions.

Further information

For detailed documentation, including compatible scales (MSD01), radial (MR02D02) and axial rings (MR01D01), data sheets and 3D models, refer to the [RLC2IA](#) product page or [RLS Media center](#).

Recommended fasteners

Recommended use of stainless steel, DIN912. For more information see **Table of recommended fastener tightening torques** at [RLS Media center](#). To avoid mechanical damage to the PCB assembly, do not use countersunk fasteners.

Technical specifications

System data

Pole length		2 mm
Maximum measuring length		50 m
System accuracy	Linear application	±10 µm/m / ±20 µm/m / ±40 µm/m Different accuracy grades of MS05 magnetic scale available. Refer to MSD01 available at RLS Media center .
	Rotary application	Axial: Refer to MR01D01 available at RLS media center . Radial: Refer to MR02D02 available at RLS media center .
Hysteresis		< 3 µm (at 0.3 mm ride height)
Repeatability (unidirectional)		< 1 µm
Reference mark		Unique / Periodic
Set-up time		< 50 ms (after power supply voltage is set in operating range)
Resolution		Max. 13 bit (~0.244 µm) For details refer to the Table of available resolutions .
Maximum speed	Linear application	Refer to MS speed calculator available at RLS website .
	Rotary application	Axial: Refer to speed calculator available at RLS website . Radial: Refer to speed calculator available at RLS website .

Electrical data

Power supply		24 V ±10 % – voltage on readhead
Current consumption		< 10.5 mA without 1000 Ω termination < 85 mA with 1000 Ω termination
Reverse polarity protection		Yes
Maximum cable length		3 m; for greater lengths contact RLS
Recommended wire gauge		28-32 AWG

Mechanical data

Mass		~2.70 g
Connection type		Molex 5015681107

Environmental data

Operating and storage temperature		-40 °C to +105 °C
Vibrations (55 Hz to 2000 Hz)		300 m/s ² (IEC 60068-2-6)
Shocks (6 ms)		300 m/s ² (IEC 60068-2-27)
Humidity		Up to 70 % non-condensing
External magnetic field during operation		< 1 mT
ESD immunity		HBM, Class 2 ±2 kV

Electrical connections

Function	Signal	Molex 501568-1107
Power	Vdd	1, 2
	GND	3, 4
Incremental signals	A+	5
	A-	6
	B+	7
	B-	8
Reference signals	Z+	10
	Z-	11
Not connected	-	9

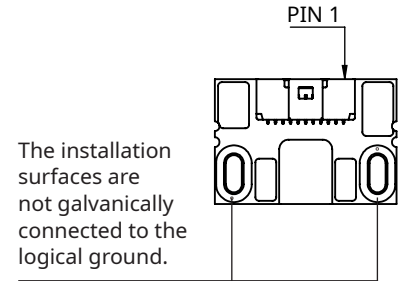

In configurations without reference mark the Z+ and Z- outputs maintain constant voltage potential levels of RS422 interface.

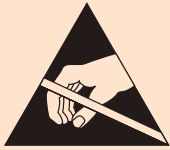

Readhead is ESD sensitive - handle with care.

Do not touch electronic circuit, wires or sensor area without proper ESD protection or outside of ESD controlled environment.

Output type

Incremental, Push-Pull output

RLC2IA

Specifications

Power supply	24 V \pm 10 %
Output signals	3 square-wave signals A, B, Z and their inverted signals A-, B-, Z-
Reference signal	1 or more square-wave pulse Z and its complementary pulse Z-
Signal level	UH \geq 23.4 V at -IH = 24 mA UL \geq 0.2 V at IL = 24 mA
Permissible load	IL \geq 50 mA max. load per output
Alarm	High impedance on output lines A, B, Z + LED indication
Switching time - A, B, Z signals (10 to 90 %)	t+ = t- < 400 ns (typ. 120 ns) Measured at capacitive load = 1000 pF

In configurations without reference mark the Z+ and Z- outputs maintain constant voltage potential levels of RS422 interface.

Timing diagram

Complementary signals not shown

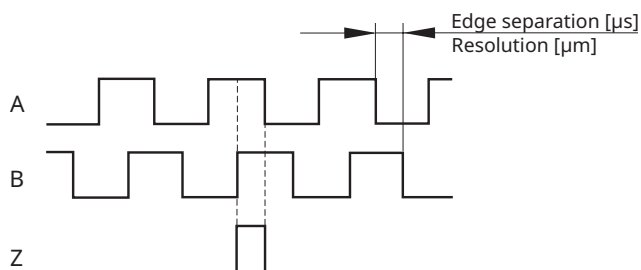

Recommended signal termination

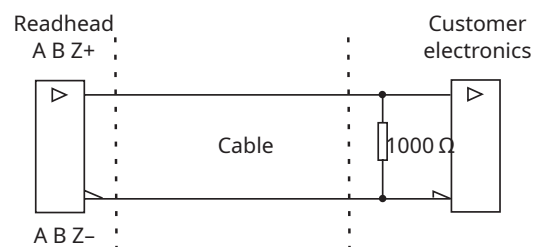

Status indicator LED

LED signal	Status
● Green	Good signal strength/set-up.
● Red	Poor signal strength. Possible reasons: <ul style="list-style-type: none"> • Incorrect readhead orientation. • Readhead installation out of tolerance. • Demagnetised or damaged measuring scale or ring. • Insufficient power supply voltage. Speed too high.

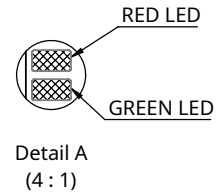

The LED should not blink when passing the reference mark on the scale or ring. If it does blink, the orientation between the scale or ring and readhead is incorrect and must be corrected.

The LED signal functions listed in the table above do not indicate non-optimal installation of the readhead, such as accuracy outside the specified range or improper operation of the reference mark.

Positive direction

Digital output signals – A leads B (magnetic scale is stationary)

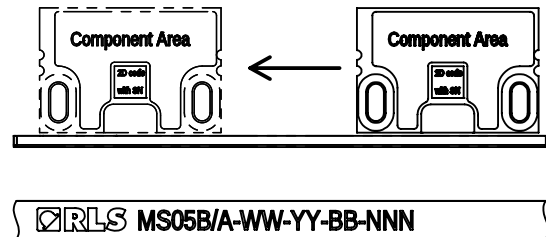

Further information

For detailed documentation, including compatible scales (MSD01), radial (MR02D02) and axial rings (MR01D01), data sheets and 3D models, refer to the [RLC2IA](#) product page or [RLS Media center](#).

Part numbering

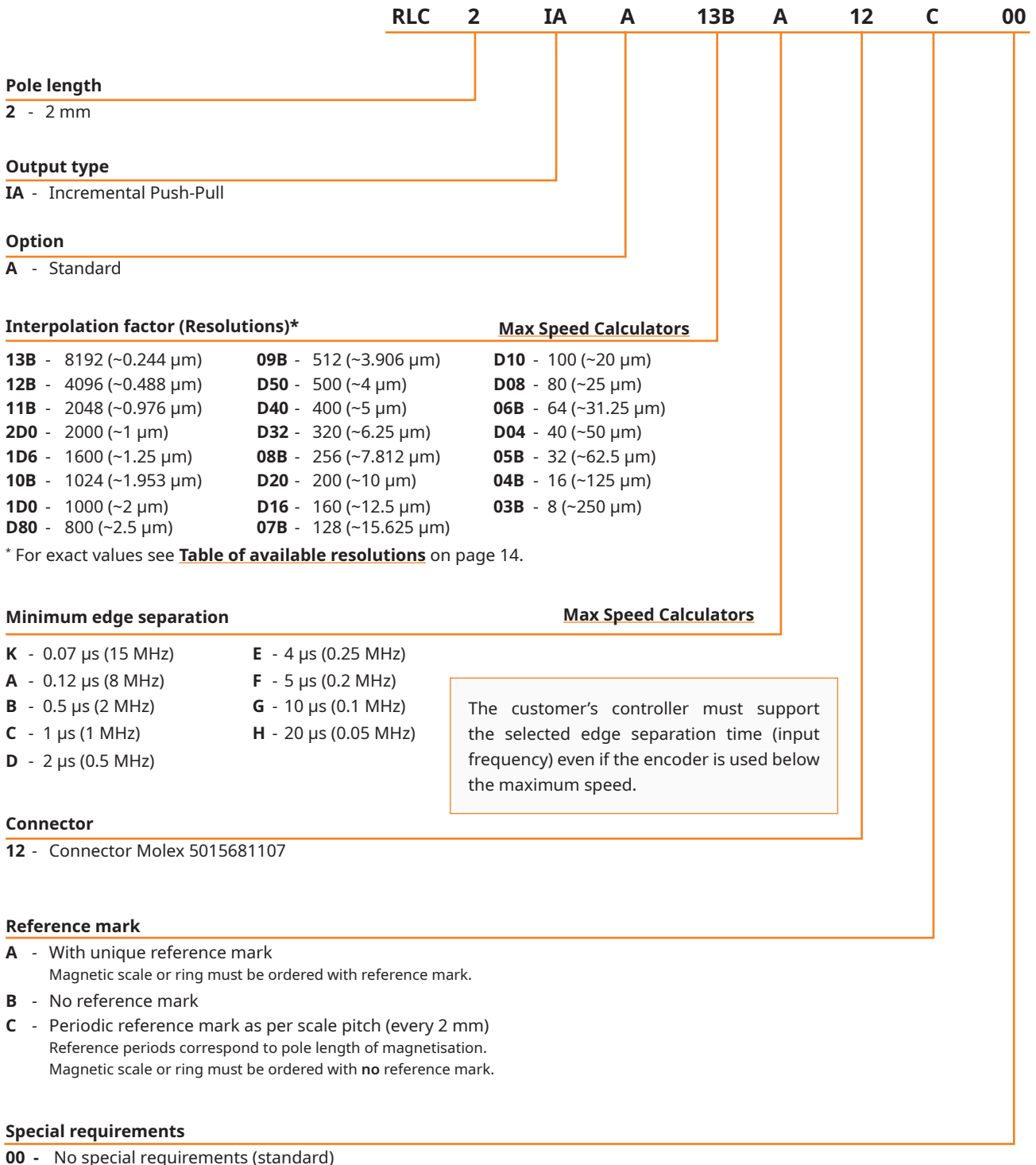

Not all part number combinations are valid. Refer to the table of available combinations on the next page.

Table of available combinations

Series	Output type	Option	Interpolation factor*	Minimum edge separation	FFC Connections	Reference	Special requirements
RLC	IA	A	13B	K / A / B / C / D / E / F / G / H	12	A / B / C	00
			12B				
			11B				
			2D0				
			1D6				
			10B				
			1D0				
			D80				
			09B				
			D50				
			D40				
			D32				
			08B				
			D20				
			D16				
			07B				
			D10				
			D08				
			06B				
			D04				
05B							
04B							
03B							

* Refer to the table on page 14 for available interpolation factors.

Further information

For detailed documentation, including compatible scales (MSD01), radial (MR02D02) and axial rings (MR01D01), data sheets and 3D models, refer to the [RLC2IA](#) product page or [RLS Media center](#).

Accessories



Cable assembly
ACC054



Cable assembly
ACC055



USB encoder interface
E201-9Q

Available resolutions

Part number	Pole length [mm]	Interpolation factor	Resolution [μm]
13B	2	2^{13}	0.244140625
12B		2^{12}	0.48828125
11B		2^{11}	0.9765625
2D0		2000	1
1D6		1600	1.25
10B		2^{10}	1.953125
1D0		1000	2
D80		800	2.5
09B		2^9	3.90625
D50		500	4
D40		400	5
D32		320	6.25
08B		2^8	7.8125
D20		200	10
D16		160	12.5
07B		2^7	15.625
D10		100	20
D08		80	25
06B		2^6	31.25
D04		40	50
05B	2^5	62.5	
04B	2^4	125	
03B	2^3	250	

Resolutions calculation

$$\text{Resolution } [\mu\text{m}] = \frac{\text{Pole length } [\mu\text{m}]}{\text{Interpolation factor}} = \frac{2000}{\text{Interpolation factor}}$$

$$\text{Resolution } [\text{ppr}] = \frac{\text{Resolution } [\text{cpr}]}{4} = \frac{\text{Pole number}^* \times \text{Interpolation factor}}{4}$$

*See pole numbers in the MR01D01 or MR02D02 data sheet at [RLS Media center](#).

Cable assemblies

Cable specifications

Part number	ACC054
Length	1 m
Cable connector	Molex 501330-1100
RLC2IA connector	Molex 501568-1107
Termination	Flying leads

Dimensions

Dimensions in mm.

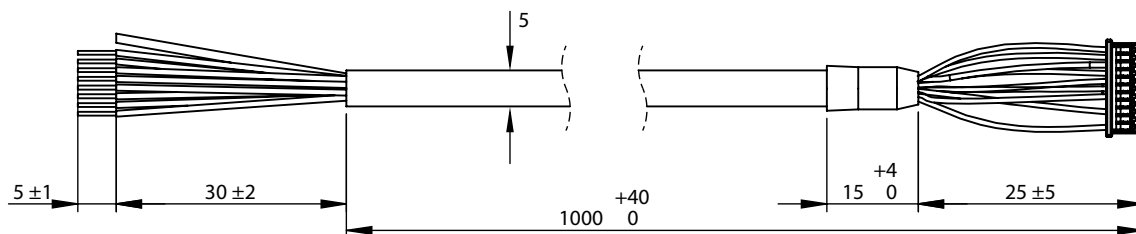

Flying leads	
Wire number	Wire color
1	Brown
2	White
3	Green
4	Yellow
5	Blue
6	Red
7	Shield
8	Pink
9	Grey

Molex 501330-1100		
Pin number	Signal	Color
1	V _{IN} +5 V	Brown
2	V _{IN} +5 V	NC
3	GND	White
4	GND	NC
5	A+	Green
6	A-	Yellow
7	B+	Blue
8	B-	Red
9	Shield	Black
10	Z+	Pink
11	Z-	Grey

Cable specifications

Part number	ACC055
Length	1 m
Cable connector	Molex 501330-1100
RLC2IA connector	Molex 501568-1107
Termination	DB-9 connector

Dimensions

Dimensions in mm.

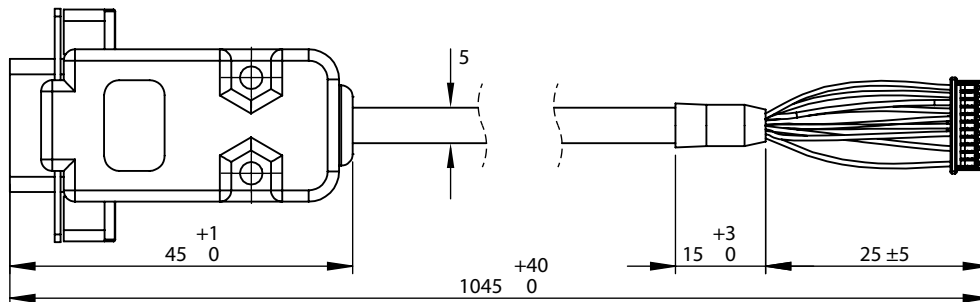

DB-9 male connector (plastic housing)	
Pin number	Wire color
1	Shield
2	Pink
3	Blue
4	Green
5	Brown
6	Grey
7	Red
8	Yellow
9	White

Molex 501330-1100		
Pin number	Signal	Wire color
1	V _{IN} +5 V	Brown
2	V _{IN} +5 V	NC
3	GND	White
4	GND	NC
5	A+	Green
6	A-	Yellow
7	B+	Blue
8	B-	Red
9	Shield	Black
10	Z+	Pink
11	Z-	Grey

The pin-out matches the pin-out on the E201-9Q interface.

Packaging

Less than 40 units are individually packed in antistatic boxes. For quantities of 20 pieces or more, the readheads are packed in trays (see table below). The trays are packed together in a cardboard box (20 trays per box).

Product variant	Tray size	Box size
RLC2IA with connector	30 units per tray	20 trays per box

Head office

RLS Merilna tehnika d. o. o.

Poslovna cona Žeje pri Komendi
Pod vrbami 2
SI-1218 Komenda
Slovenia

T +386 1 5272100
E mail@rls.si
www.rls.si

Global support

Visit our [website](#) to contact your nearest sales representative.

Document issues

Issue	Date	Page	Description
01	19. 5. 2026	-	New document

This product is not designed or intended for use outside the environmental limitations and operating parameters expressly stated on the product's datasheet. Products are not designed or intended for use in medical, military, aerospace, automotive or oil & gas applications or any safety-critical applications where a failure of the product could cause severe environmental or property damage, personal injury or death. Any use in such applications must be specifically agreed to by seller in writing, and is subject to such additional terms as the seller may impose in its sole discretion. Use of products in such applications is at buyer's own risk, and buyer will indemnify and hold harmless seller and its affiliates against any liability, loss, damage or expense arising from such use. Information contained in this datasheet was derived from product testing under controlled laboratory conditions and data reported thereon is subject to the stated tolerances and variations, or if none are stated, then to tolerances and variations consistent with usual trade practices and testing methods. The product's performance outside of laboratory conditions, including when one or more operating parameters is at its maximum range, may not conform to the product's datasheet. Further, information in the product's datasheet does not reflect the performance of the product in any application, end-use or operating environment buyer or its customer may put the product to. Seller and its affiliates make no recommendation, warranty or representation as to the suitability of the product for buyer's application, use, end-product, process or combination with any other product or as to any results buyer or its customer might obtain in their use of the product. Buyer should use its own knowledge, judgment, expertise and testing in selecting the product for buyer's application, end-use and/or operating environment, and should not rely on any oral or written statement, representation, or samples made by seller or its affiliates for any purpose. EXCEPT FOR THE WARRANTIES EXPRESSLY SET FORTH IN THE SELLER'S TERMS AND CONDITIONS OF SALE, SELLER MAKES NO WARRANTY EXPRESS OR IMPLIED WITH RESPECT TO THE PRODUCT, INCLUDING ANY WARRANTY OF MERCHANTABILITY OR FITNESS FOR ANY PARTICULAR PURPOSE, WHICH ARE DISCLAIMED AND EXCLUDED. All sales are subject to seller's exclusive terms and conditions of sale which, where the seller is (a) RLS Merilna tehnika d. o. o., are available at <https://www.rls.si/eng/salesterms>, (b) Renishaw, Inc., are available at <https://www.renishaw.com/legal/en/-42186>, or (c) another person, are available on request, and in each case, are incorporated herein by reference, and are the exclusive terms of sale. No other terms and conditions apply. Buyer is not authorized to make any statements or representations that expand upon or extend the environmental limitations and operating parameters of the products, or which imply permitted usage outside of that expressly stated on the datasheet or agreed to in writing by seller.

RLS Merilna tehnika d. o. o. has made considerable effort to ensure the content of this document is correct at the date of publication but makes no warranties or representations regarding the content. RLS Merilna tehnika d. o. o. excludes liability, howsoever arising, for any inaccuracies in this document. © 2026 RLS d. o. o.