

# SpinCo™

## Incremental Magnetic Encoder System

SPINDLE ENCODER

HIGH SPEED

ROBUST DESIGN

**SpinCo is an incremental magnetic encoder system designed for use as primary position and speed feedback sensor for machine tool spindles.**

It consists of two key elements, a readhead and a magnetic ring.

RLS proven AMR and GMR sensor technologies are used for sensing magnetized pattern on the magnetic ring to ensure accurate and reliable operation over the entire operating range.



## Features and benefits

- ▶ Speeds up to 55,000 rpm
- ▶ From 50 to 556 sin/cos periods per revolution
- ▶ ABZ digital incremental outputs with up to 4,096 steps per sin/cos period
- ▶ Analogue output signals (1 V<sub>pp</sub>)
- ▶ Signal stability
- ▶ IP67 protection
- ▶ Wide installation tolerances
- ▶ Small readhead size
- ▶ High accuracy



SPINDLE



INDUSTRIAL AUTOMATION



HARSH ENVIRONMENT



MOTOR CONTROL



ASSEMBLY LINES

## General information

The encoder continuously calibrates the sensed signals to ensure accurate and reliable output signals, which are reported as industry standard 1 V<sub>pp</sub> analogue incremental signals.

The magnetic ring consists of an elastoferrite layer firmly bonded to a stainless steel hub. The elastoferrite layer is magnetised with alternating magnetic poles. The poles can be 1 mm or 2 mm long. To ensure safety and reliability even at the highest rotational speeds, all magnetic rings have a fully welded cover foil. This thin steel layer protects the elastoferrite from damage and the effects of cooling lubricant vapours and ensures optimum performance at high speeds and high temperatures. Various outer diameters are supported, ranging from 31 mm to 176 mm. The magnetic ring can be mounted by shrinkage press fitting, press fitting, gluing or by using fasteners.

The shape of the readhead has been designed to minimise the required mounting space. In addition, a visible status LED is provided to facilitate installation and troubleshooting. The readhead features an AGC that enables an optimum output signal within the installation tolerances, regardless of the ride height.

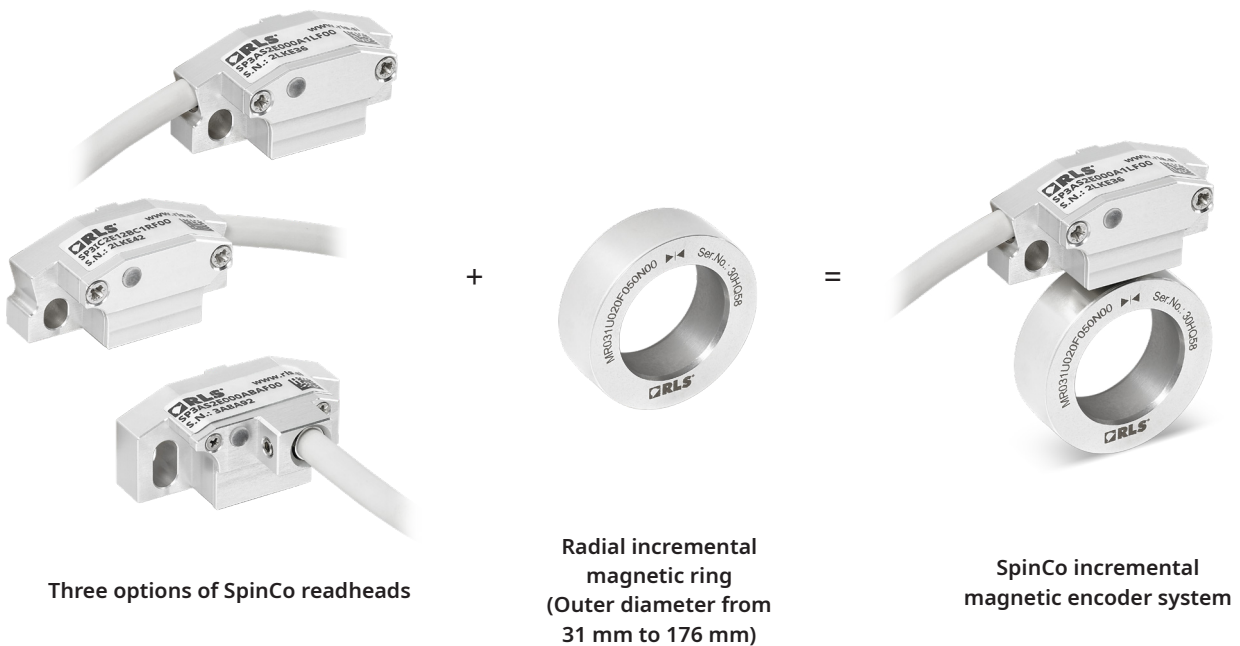

## Choose your SpinCo magnetic encoder system

SpinCo system with right tangential cable exit



SpinCo system with left tangential cable exit



SpinCo system with axial cable exit



# Storage and handling

## Storage temperature



-40 °C to +85 °C

## Operating temperature



-40 °C to +85 °C

## Humidity



IP67 (according to IEC 60529)

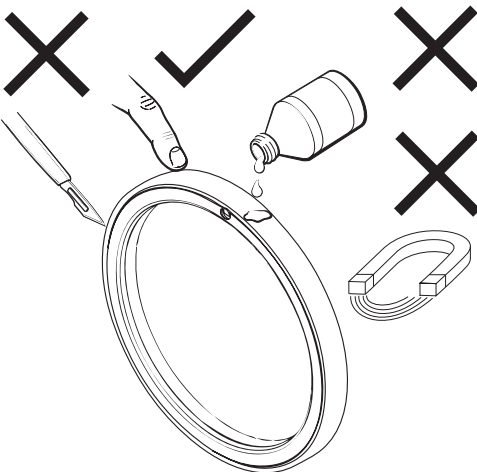
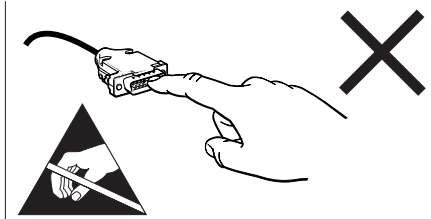
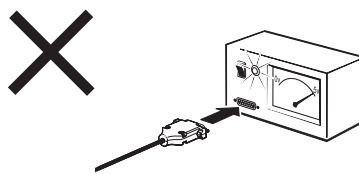
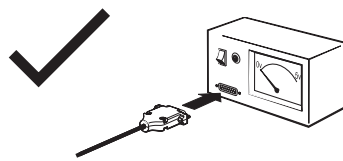

**HANDLE WITH CARE.** This encoder system is a high performance metrology product and should be handled with the same care as any other precision instrument. The use of industrial tools such as hammers and chisels or exposure to strong magnets such as a magnetic base is unacceptable and carries the risk of irreparable damage to the product.

The magnetic ring should not be exposed to magnetic field densities higher than 25 mT on its surface, as this can damage the ring.

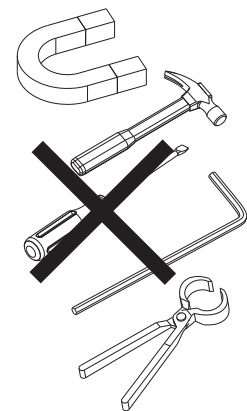

## Exposure to external magnetic fields during operation

<1 mT AC (alternating field)

<2 mT DC (static field)

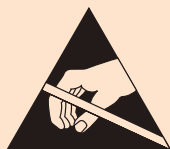

**Readhead is ESD sensitive - handle with care.**

Do not touch electronic circuit, wires or sensor area without proper ESD protection or outside of ESD controlled environment.

## Packaging

Each readhead is packed individually in an antistatic bag.

Each magnetic ring is packed individually in an antistatic box.

# Dimensions and installation drawings

Dimensions and tolerances are in mm.

## Magnetic ring surface markings (engraved)

Magnetic ring markings include serial number, QR code, logo, part number and reference mark. They are engraved on the hub. The reference mark engraving can deviate from the actual position of the reference mark magnetization for  $\pm 5^\circ$ . The engraving is for orientation purposes only.



YD1B70

Reference mark sign

Serial number example  
- unique combination  
of six letters and digits

## Encoder assembly with MRxxxU ring (MR176X not included)

### With left/right tangential cable exit

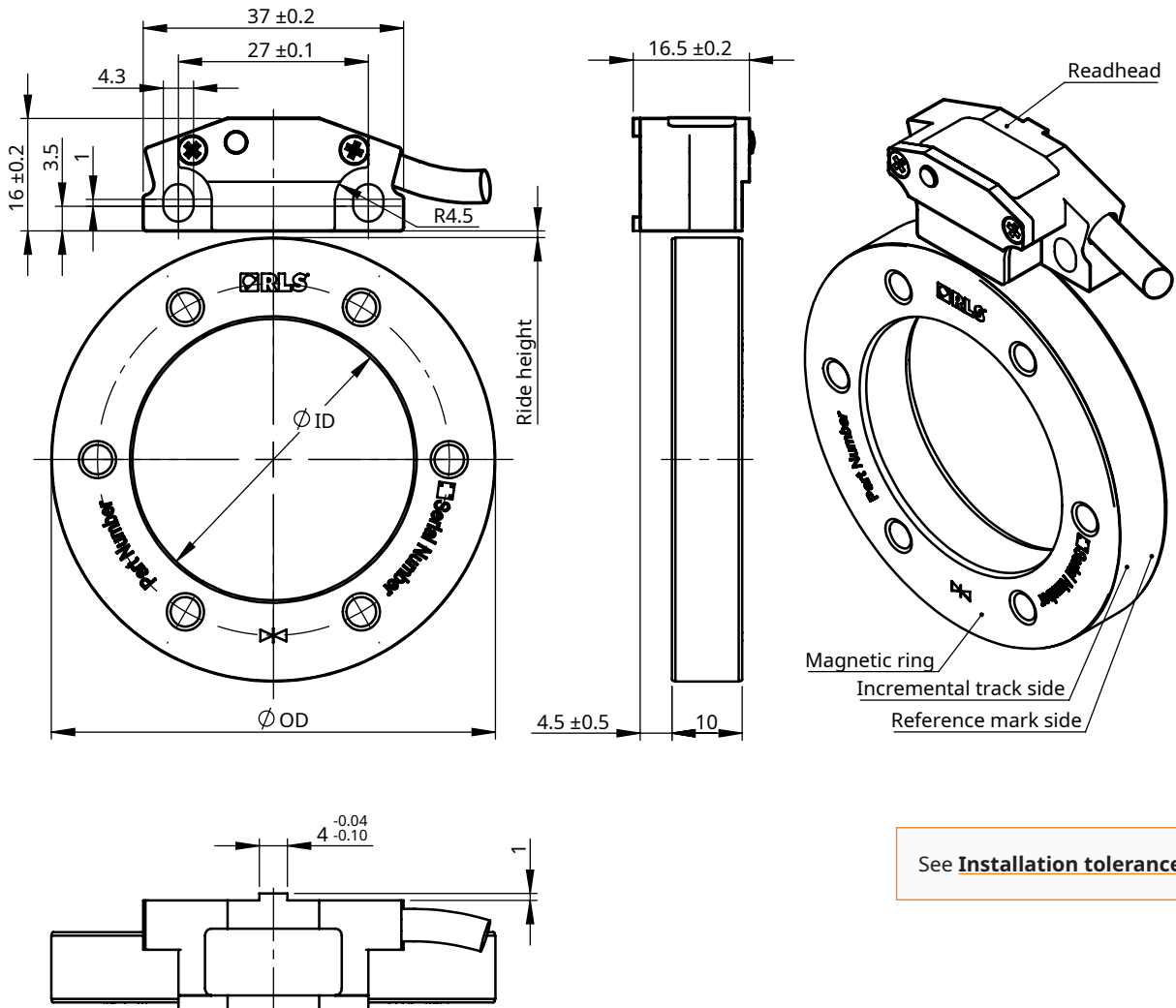

See **Installation tolerances**

**With axial cable exit**

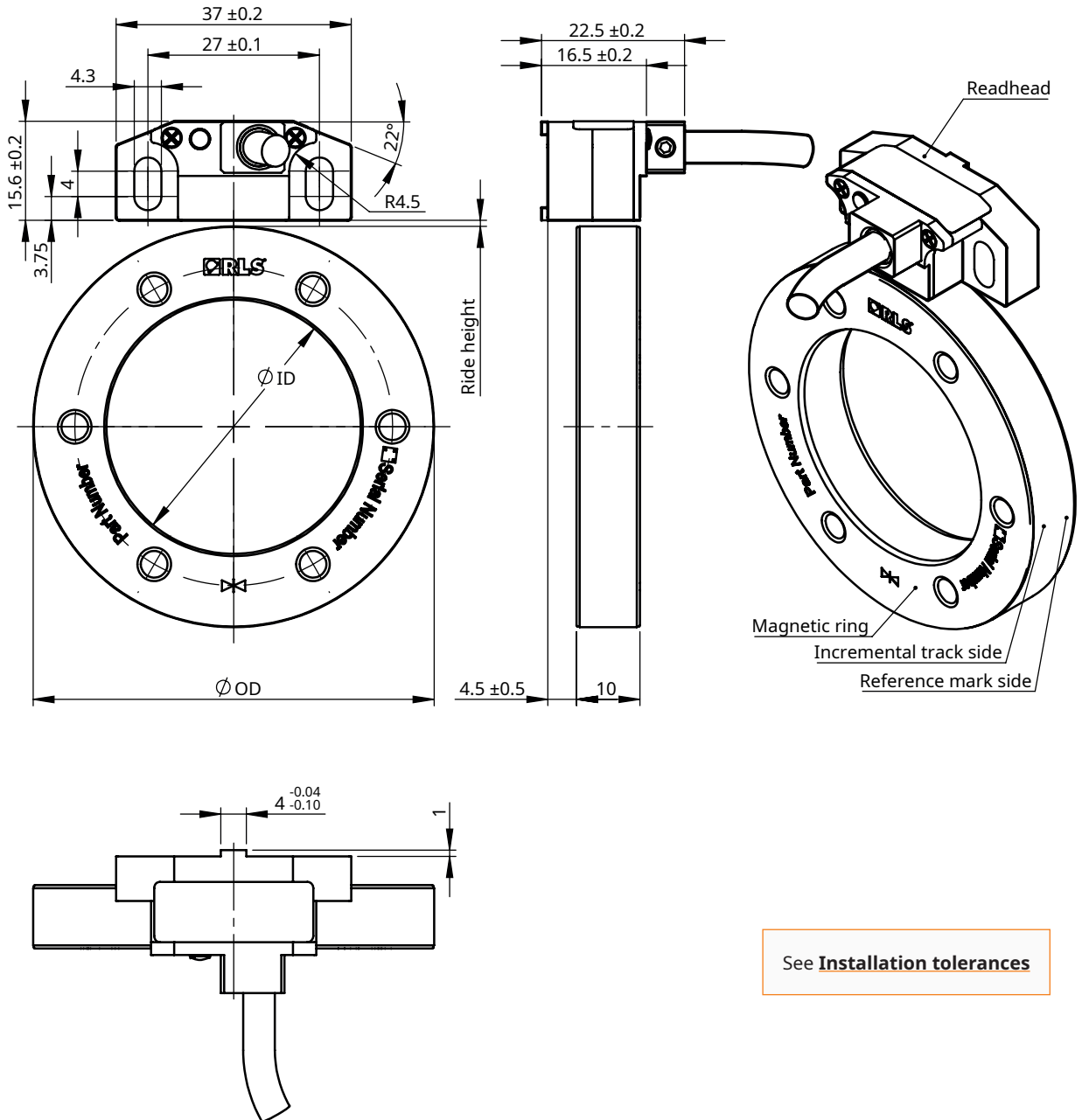

See **Installation tolerances**

## Encoder assembly with MR176X ring

### With left/right tangential cable exit

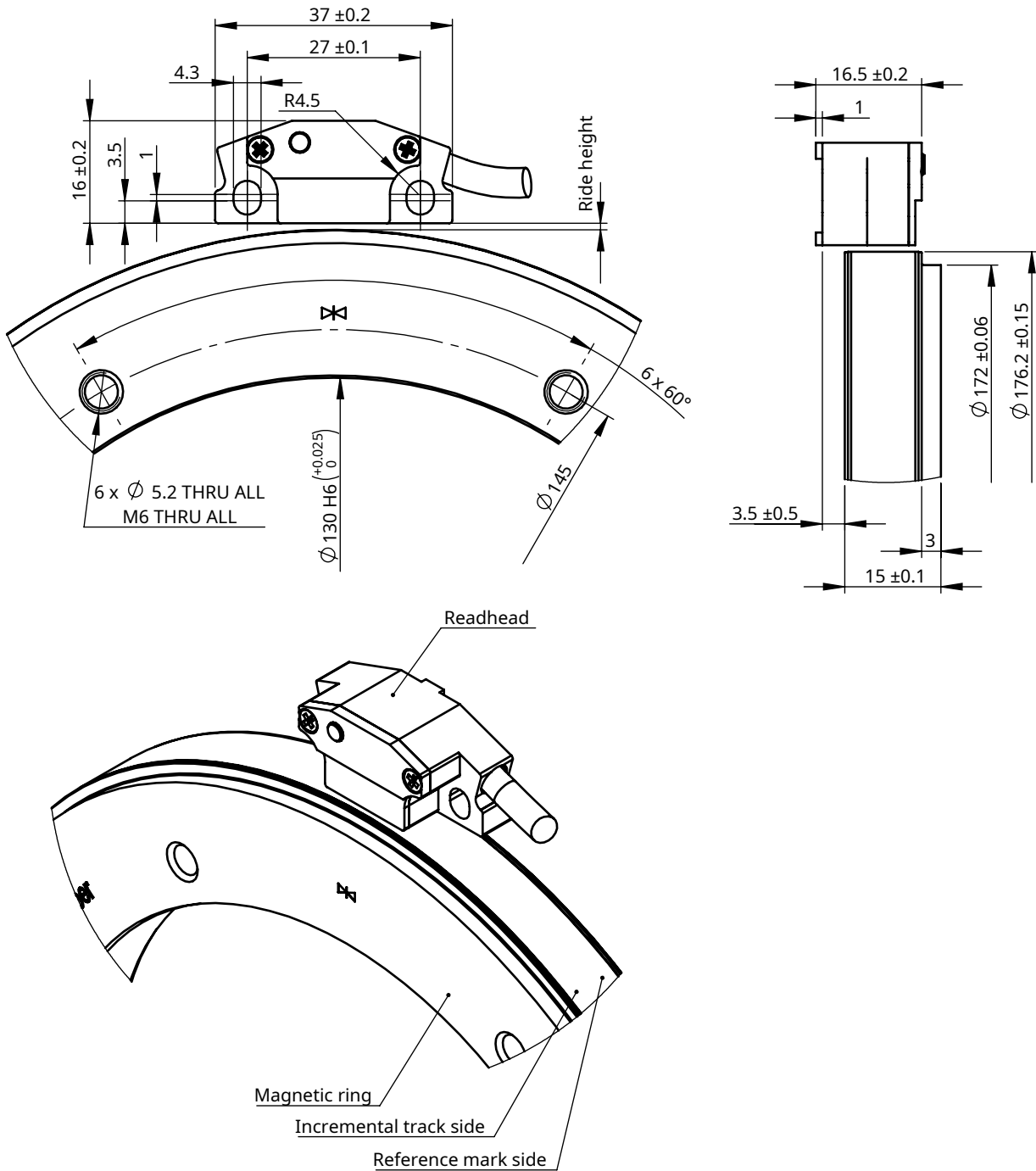

**With axial cable exit**

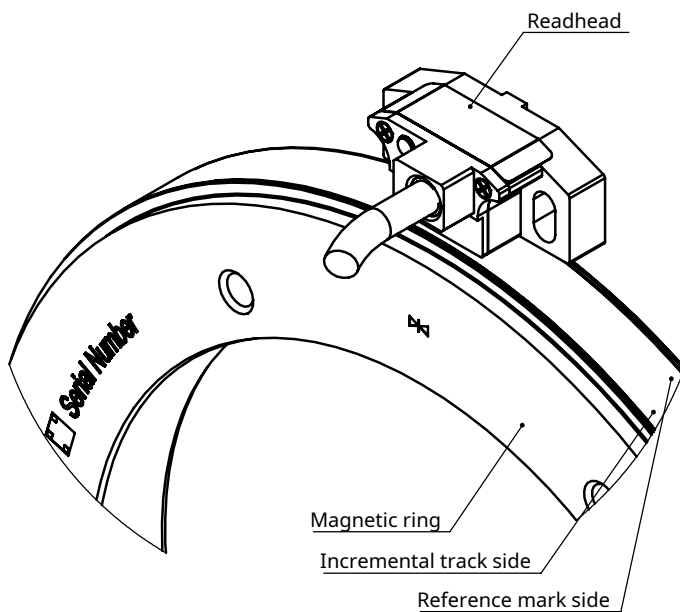
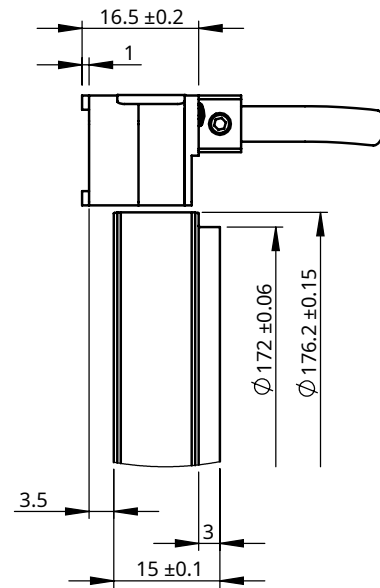
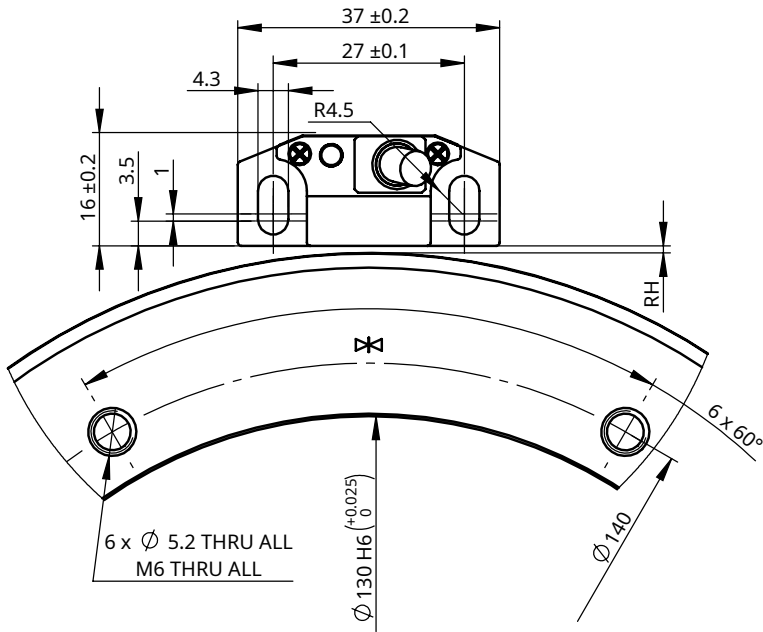

## Installation tolerances (readhead to ring)

<b>Radial displacement (Ride height)</b>	1 mm pole length	0.2 ±0.1 mm
	2 mm pole length	0.3 ±0.2 mm



<b>Axial displacement</b>	±0.5 mm
---------------------------	---------



<b>Tangential displacement of the sensor</b>	±0.5 mm
--	---------



<b>Non-parallel mounting (roll)</b>	±0.5°
-------------------------------------	-------

<b>Non-parallel mounting (yaw)</b>	±0.5°
------------------------------------	-------

<b>Non-parallel mounting (pitch)</b>	±1°
--------------------------------------	-----

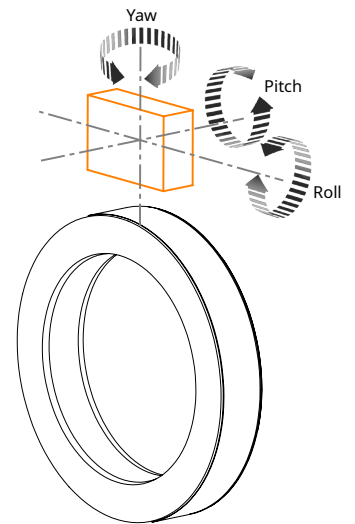

Magnetic ring



SpinCo readhead



## Magnetic rings

### MR031U

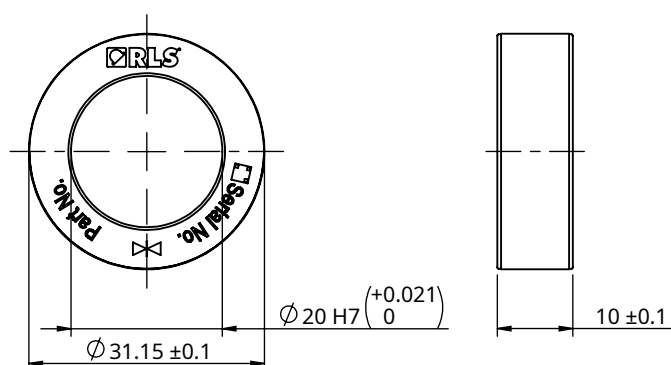

## Technical features

Pole length (mm)	1	2
Number of poles	100	50
Ride height (mm)	0.2 ± 0.1	0.3 ± 0.2
Outer diameter (mm)	31.15 ± 0.1	
Inner diameter (mm)	20	
Mass (g)	31	
Maximum speed	Refer to <a href="#">Maximum speed calculator</a>	
Moment of inertia (kgmm <sup>2</sup> )	5.3	
Accuracy of magnetisation (°)	±0.06	±0.1
Interpolation accuracy / SDE (°)	±0.015	±0.025

**MR040U**

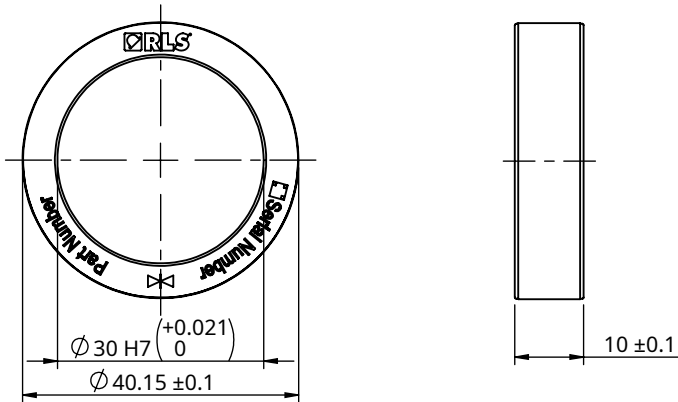

**Technical features**

Pole length (mm)	1	2
Number of poles	128	64
Ride height (mm)	$0.2 \pm 0.1$	$0.3 \pm 0.2$
Outer diameter (mm)	$40.15 \pm 0.1$	
Inner diameter (mm)	30	
Mass (g)	39	
Maximum speed	Refer to <b>Maximum speed calculator</b>	
Moment of inertia (kgmm <sup>2</sup> )	12.1	
Accuracy of magnetisation (°)	$\pm 0.05$	$\pm 0.08$
Interpolation accuracy / SDE (°)	$\pm 0.012$	$\pm 0.022$

MR050U

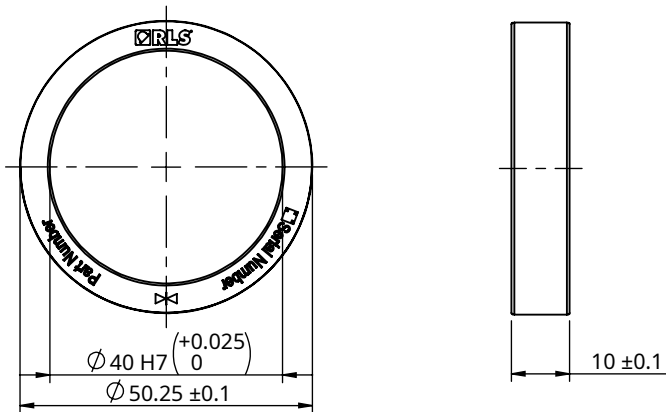

Technical features

Pole length (mm)	1	2
Number of poles	160	80
Ride height (mm)	$0.2 \pm 0.1$	$0.3 \pm 0.2$
Outer diameter (mm)	$50.25 \pm 0.1$	
Inner diameter (mm)	40	
Mass (g)	51	
Maximum speed	Refer to <b>Maximum speed calculator</b>	
Moment of inertia (kgmm <sup>2</sup> )	25.9	
Accuracy of magnetisation (°)	$\pm 0.04$	$\pm 0.07$
Interpolation accuracy / SDE (°)	$\pm 0.01$	$\pm 0.02$

Dimensions and installation drawings continued

MR063U ID40

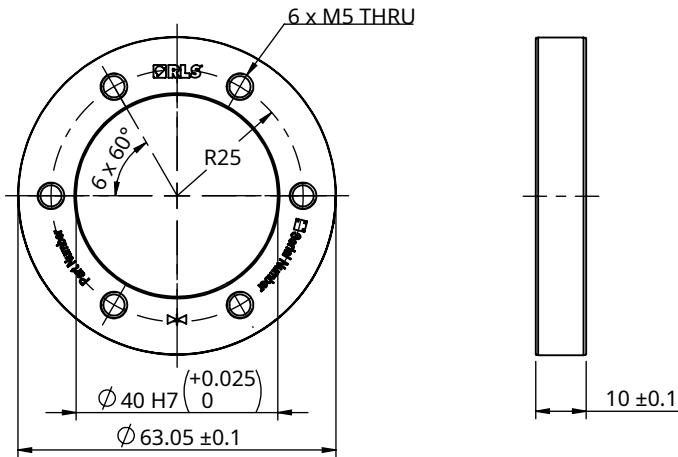

Technical features

Pole length (mm)	1	2
Number of poles	200	100
Ride height (mm)	0.2 ± 0.1	0.3 ± 0.2
Outer diameter (mm)	63.05 ± 0.1	
Inner diameter (mm)	40	
Mass (g)	131	
Maximum speed	Refer to <b>Maximum speed calculator</b>	
Moment of inertia (kgmm <sup>2</sup> )	90.3	
Accuracy of magnetisation (°)	±0.035	±0.06
Interpolation accuracy / SDE (°)	±0.008	±0.015

**MR063U ID50**

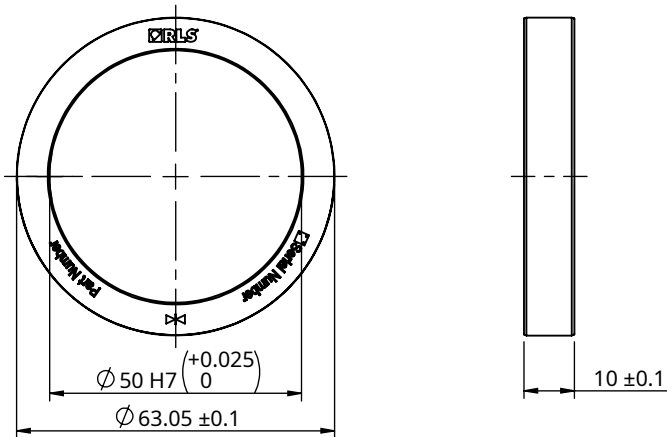

**Technical features**

Pole length (mm)	1	2
Number of poles	200	100
Ride height (mm)	0.2 ± 0.1	0.3 ± 0.2
Outer diameter (mm)	63.05 ± 0.1	
Inner diameter (mm)	50	
Mass (g)	83	
Maximum speed	Refer to <b>Maximum speed calculator</b>	
Moment of inertia (kgmm <sup>2</sup> )	66.3	
Accuracy of magnetisation (°)	±0.035	±0.06
Interpolation accuracy / SDE (°)	±0.008	±0.015

Dimensions and installation drawings continued

MR081U

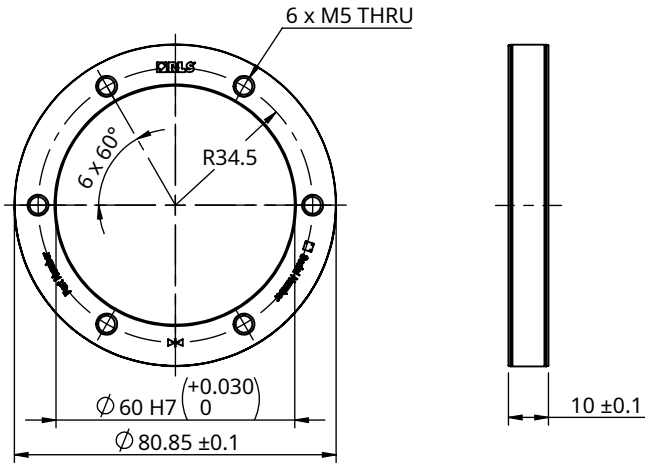

Technical features

Pole length (mm)	1	2
Number of poles	256	128
Ride height (mm)	0.2 ± 0.1	0.3 ± 0.2
Outer diameter (mm)	80.85 ± 0.1	
Inner diameter (mm)	60	
Mass (g)	163	
Maximum speed	Refer to <b>Maximum speed calculator</b>	
Moment of inertia (kgmm <sup>2</sup> )	204.9	
Accuracy of magnetisation (°)	±0.03	±0.05
Interpolation accuracy / SDE (°)	±0.007	±0.014

MR114U

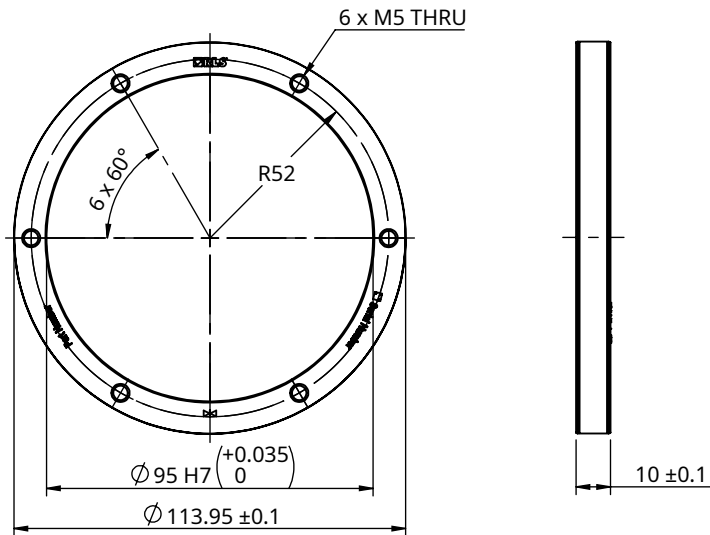

Technical features

Pole length (mm)	1	2
Number of poles	360	180
Ride height (mm)	0.2 ± 0.1	0.3 ± 0.2
Outer diameter (mm)	113.95 ± 0.1	
Inner diameter (mm)	95	
Mass (g)	221	
Maximum speed	Refer to <b>Maximum speed calculator</b>	
Moment of inertia (kgmm <sup>2</sup> )	604	
Accuracy of magnetisation (°)	±0.02	±0.04
Interpolation accuracy / SDE (°)	±0.006	±0.012

Dimensions and installation drawings continued

MR127U

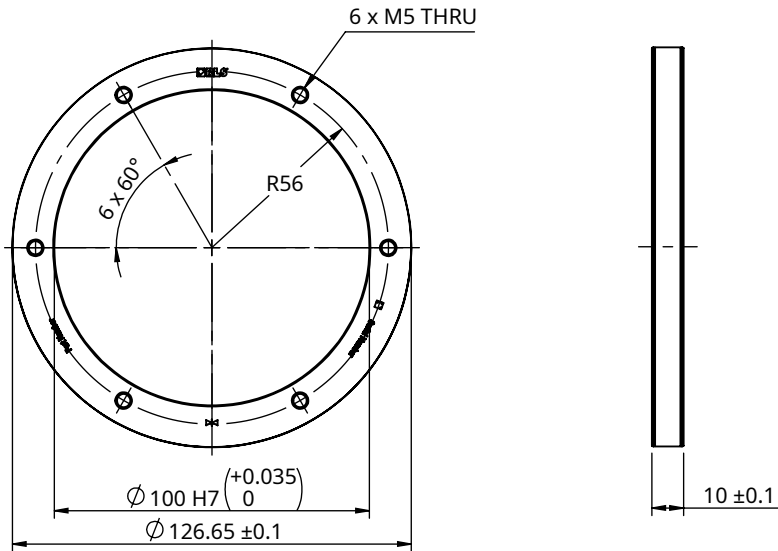

Technical features

Pole length (mm)	1	2
Number of poles	400	200
Ride height (mm)	0.2 ± 0.1	0.3 ± 0.2
Outer diameter (mm)	126.65 ± 0.1	
Inner diameter (mm)	100	
Mass (g)	345	
Maximum speed	Refer to <a href="#">Maximum speed calculator</a>	
Moment of inertia (kgmm <sup>2</sup> )	1118	
Accuracy of magnetisation (°)	± 0.02	± 0.04
Interpolation accuracy / SDE (°)	± 0.005	± 0.01

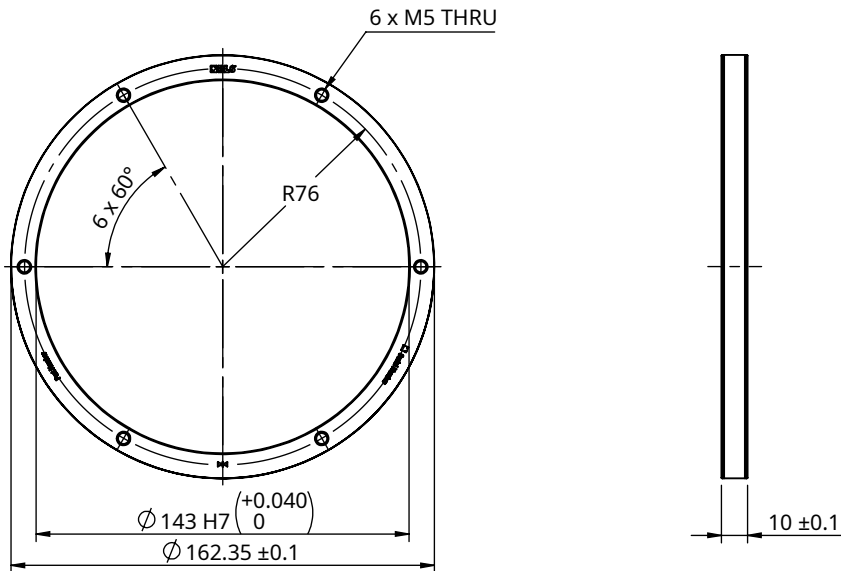

**MR162U**

**Technical features**

<b>Pole length (mm)</b>	1	2
<b>Number of poles</b>	512	256
<b>Ride height (mm)</b>	0.2 ± 0.1	0.3 ± 0.2
<b>Outer diameter (mm)</b>	162.35 ± 0.1	
<b>Inner diameter (mm)</b>	143	
<b>Mass (g)</b>	334	
<b>Maximum speed</b>	Refer to <a href="#">Maximum speed calculator</a>	
<b>Moment of inertia (kgmm<sup>2</sup>)</b>	1948.1	
<b>Accuracy of magnetisation (°)</b>	±0.015	±0.03
<b>Interpolation accuracy / SDE (°)</b>	±0.003	±0.006

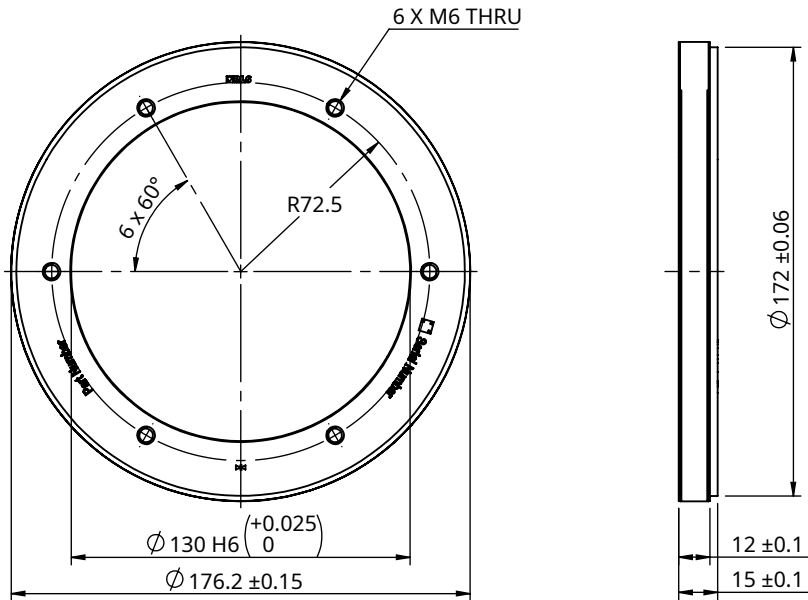
MR176X



Technical features

Pole length (mm)	1
Number of poles	556
Ride height (mm)	0.2 ± 0.1
Outer diameter (mm)	176.2 ± 0.15
Inner diameter (mm)	130
Mass (g)	1200
Maximum speed	Refer to <b>Maximum speed calculator</b>
Moment of inertia (kgmm <sup>2</sup> )	7225
Accuracy of magnetisation (°)	±0.015
Interpolation accuracy / SDE (°)	±0.002

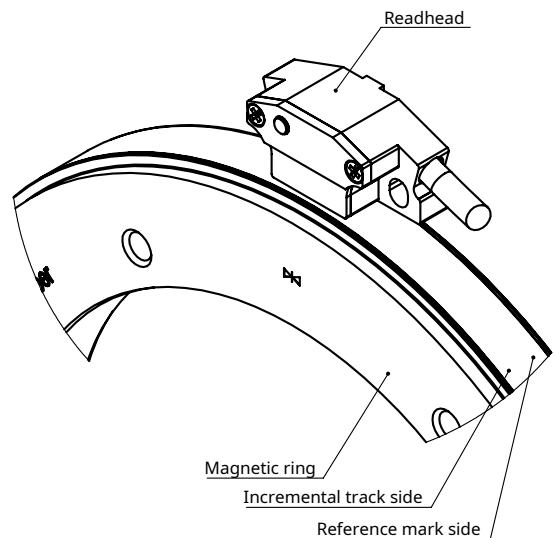

See the encoder assembly on the following page.

## Positive direction

---

**Digital output signals** – A leads B (magnetic scale is stationary)

**Analogue output signals** ( $1 V_{pp}$ ) –  $V_1$  leads  $V_2$

The arrow represents positive direction of the readhead.

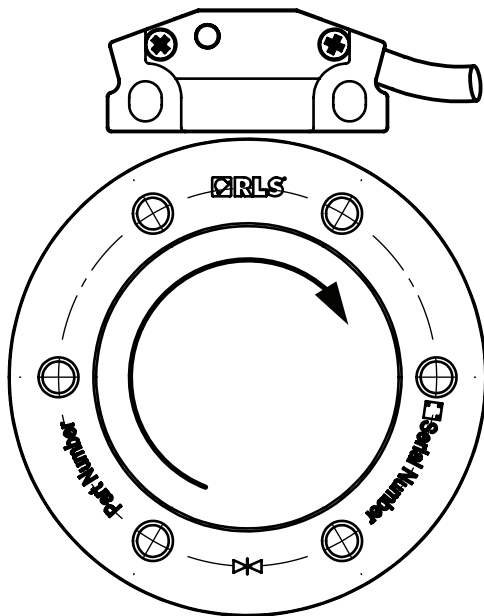

# Installation instructions

## Installation of magnetic rings

Machine the mounting shaft according to the dimensions given in the table below.  
Dimensions and tolerances are in mm.

Ring	Outer diameter - OD	Inner diameter - ID	Shaft diameter (clearance fit installation, fasteners, gluing) - Ds		Shaft outer diameter (press fit or shrinkage press fit) - Dspd	
MR031U020	31.15 ±0.1	20 H7	20 g6	-0.007 -0.02	20 r6	0.041 0.028
MR040U030	40.15 ±0.1	30 H7	30 g6	-0.007 -0.02	30 r6	0.041 0.028
MR050U040	50.25 ±0.1	40 H7	40 g6	-0.009 -0.025	40 r6	0.05 0.034
MR063U040	63.05 ±0.1	40 H7	40 g6	-0.009 -0.025	40 r6	0.05 0.034
MR063U050	63.05 ±0.1	50 H7	50 g6	-0.009 -0.025	50 r6	0.05 0.034
MR081U060	80.85 ±0.1	60 H7	60 g6	-0.01 -0.029	60 r6	0.06 0.041
MR114U095	113.95 ±0.1	95 H7	95 g6	-0.012 -0.034	95 r6	0.073 0.051
MR127U100	126.65 ±0.1	100 H7	100 g6	-0.012 -0.034	100 r6	0.073 0.051
MR162U143	162.35 ±0.1	143 H7	143 g6	-0.014 -0.039	143 r6	0.09 0.065
MR176X130	176.2 ±0.15	130 H6	130 g5	-0.014 -0.032	130 p5	0.061 0.043

## Installation by press-fitting

Slip the ring onto the mating shaft applying equal or uniform force along the whole ring circumference.

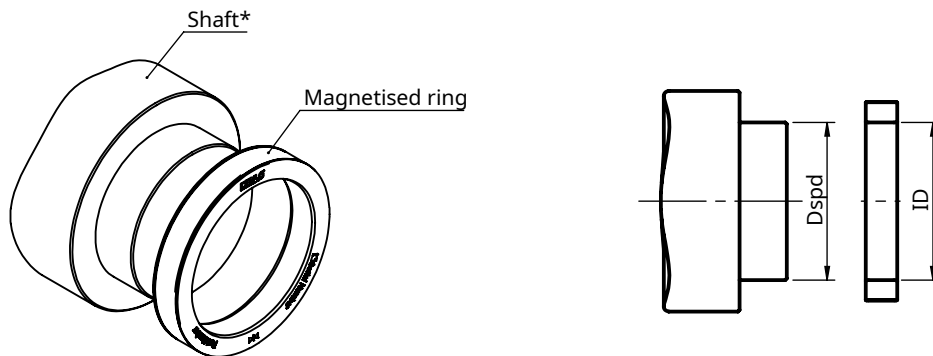

\* Not provided.

## Installation with fasteners

1. Slide the ring onto the mating shaft.
2. Attach the ring with appropriate fasteners.

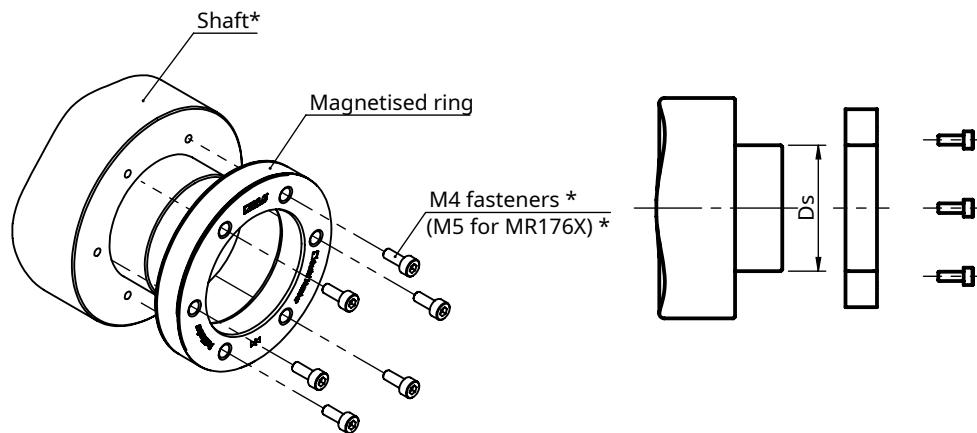

\* Not provided.

See table of recommended tightening torques for RLS products (document TTD01) available at [RLS media center](#).

## Installation by gluing

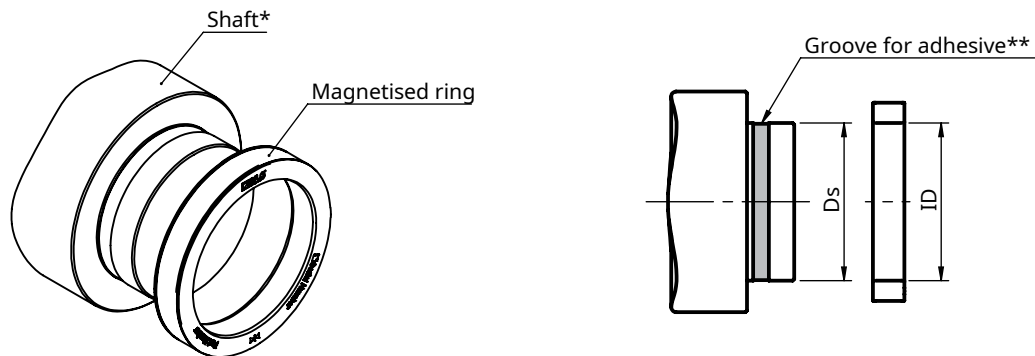

\* Not provided.

\*\* For the depth of the groove, please check the specifications of the adhesive.

## Installation of the readhead

Please use the supplied spacer for optimum ride height. For proper mounting, a mounting base should be made prior to installation.

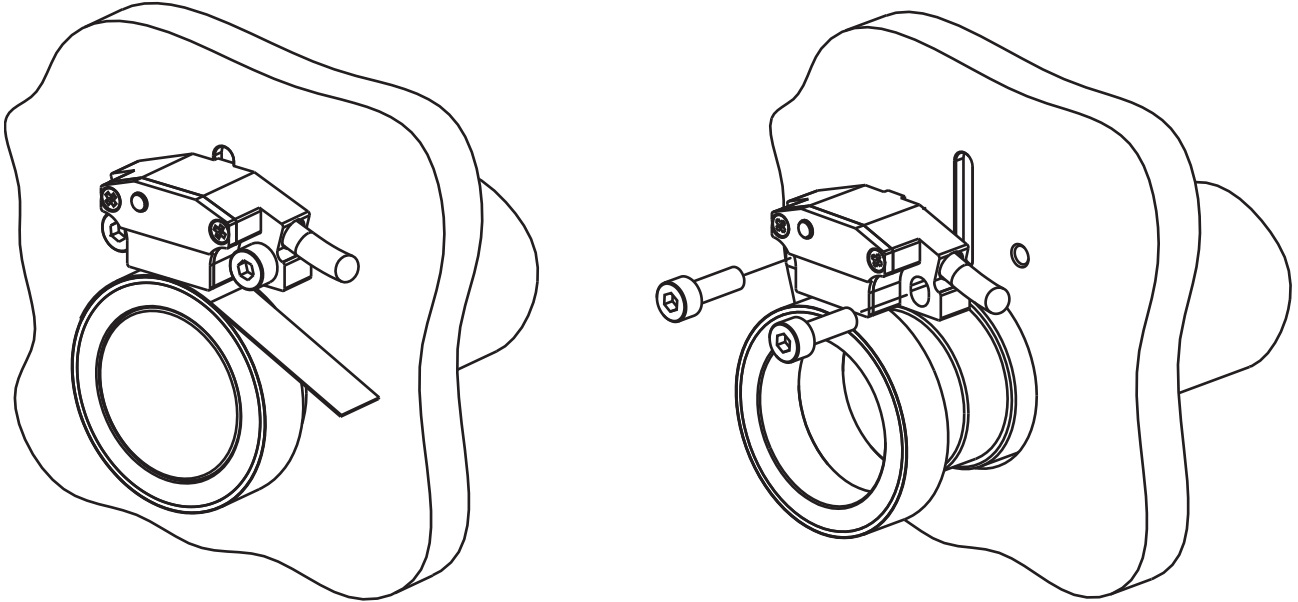

## Mounting base

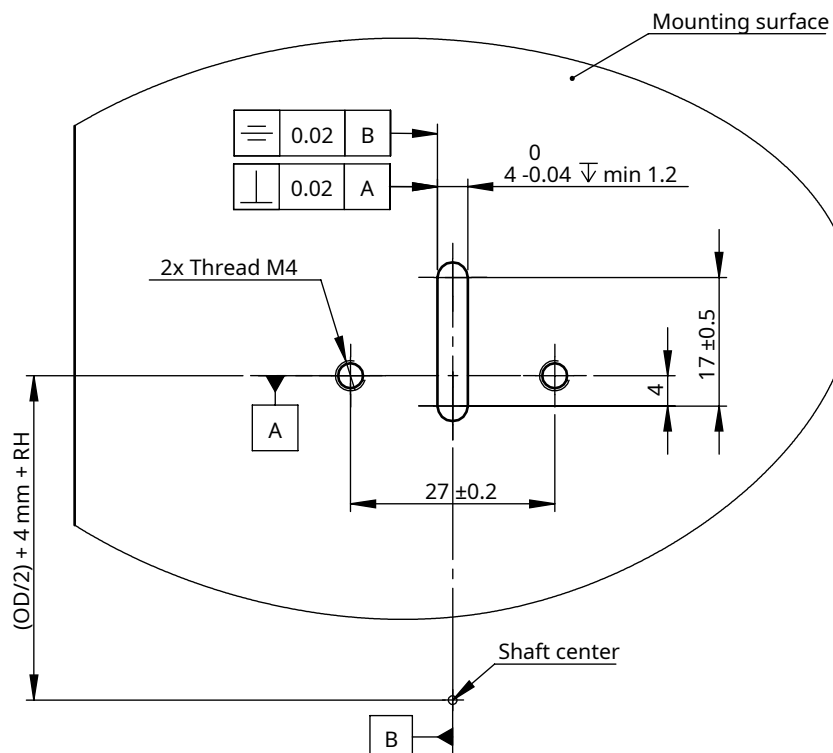

## Technical specifications

### System data

<b>Pole length</b>	1 mm or 2 mm
<b>Hysteresis</b>	Less than 1 electrical degree
<b>Repeatability</b>	Less than $\pm 2$ counts for maximum interpolation factor and less than unit of resolution for all other interpolation factors

### Electrical data

<b>Supply voltage</b>	5 V $\pm 10$ % (absolute maximum 6 V) Reverse polarity and overvoltage protected
<b>Current consumption</b>	<50 mA (without load)
<b>Set-up time</b>	100 ms
<b>Interface</b>	1 V <sub>pp</sub> or digital TTL (RS422)

### Mechanical data

<b>Mass</b>	Readhead: 120 g (1 m cable, no connector)
<b>Cable</b>	TPE AWG 26, shielded, $\varnothing 4.8 \pm 0.15$ mm
<b>Ring hub material</b>	EN 1.4057
<b>Coefficient of thermal expansion (CTE) of steel hub of the ring (ppm/°C)</b>	11.2

### Environmental data

<b>Temperature</b>	-40 °C to +85 °C (Operating and storage)
<b>Environmental sealing</b>	IP67 (according to IEC 60529)*
<b>EMC Immunity</b>	EN 61000-4-2
<b>EMC Emission</b>	EN 61000-6-4
<b>Vibrations</b>	55 Hz to 2000 Hz: 300 m/s <sup>2</sup> (EN 60068-2-6)
<b>Shocks</b>	11 ms: 1000 m/s <sup>2</sup> (EN 60068-2-27)

\* IP protection is only guaranteed when suitable connector with same or higher IP is used.

## Electrical connections

### Connector options

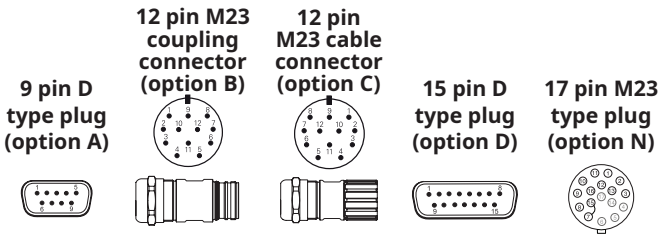
Function	Signal (analogue)	Signal (quadrature)	Colour of flying lead (option F)					
				9 pin D type plug (option A)	12 pin M23 coupling connector (option B)	12 pin M23 cable connector (option C)	15 pin D type plug (option D)	17 pin M23 type plug (option N)
Power	5 V	5 V	Brown	5	12	12	4	10
	0 V	0 V	White	9	10	10	12	7
	5 V sense	5 V sense	Black	-	2	2	8	16
	0 V sense	0 V sense	Purple	-	11	11	15	15
Incremental / analogue signals	V <sub>1</sub>	A	Green	4	5	5	9	1
	V <sub>1-</sub>	A-	Yellow	8	6	6	1	2
	V <sub>2</sub>	B	Blue	3	8	8	10	11
	V <sub>2-</sub>	B-	Red	7	1	1	2	12
Reference mark	V <sub>0</sub>	Z	Pink	2	3	3	3	3
	V <sub>0-</sub>	Z-	Grey	6	4	4	11	13
Shield	Shield	Shield	-	Case	Case	Case	Case	Case

When using flying lead connection type shield must be connected to custom connector or controllers shield connection pin.

## Status indicator LED

LED colour	Output signals	Possible cause
<span style="color: green;">●</span> Green	VALID	Normal operation; position data is valid
<span style="color: red;">●</span> Red	INVALID	<ul style="list-style-type: none"> <li>• Rotational speed too high.</li> <li>• Sensing distance too high.</li> <li>• Improper orientation of magnetised ring relative to readhead.</li> <li>• Magnetically damaged magnetised ring.</li> <li>• External magnetic field too high.</li> </ul>

## AGC - automatic gain control

If the strength of the magnetic field is changing, the internal AGC (automatic gain control) circuit is able to control the output signal amplitude around 1 V<sub>pp</sub>. Via AGC SpinCo can monitor and keep the output signals for the ensuing sine-to-digital conversion constant regardless of changes in input signal level.



# Maximum speed

For operation without errors during high speed rotation, correct edge separation setting must be selected. Edge separation can be calculated according to following equation:

$$t_{MDT} = \frac{1}{\frac{RPM}{60} \times STEP \times Pole\ count}$$

### Available edge separations:

<b>B</b>	25 ns	<b>F</b>	125 ns	<b>J</b>	400 ns	<b>N</b>	1.3 μs
<b>C</b>	50 ns	<b>G</b>	150 ns	<b>K</b>	550 ns	<b>O</b>	1.6 μs
<b>D</b>	75 ns	<b>H</b>	200 ns	<b>L</b>	800 ns	<b>P</b>	3.2 μs
<b>E</b>	100 ns	<b>I</b>	300 ns	<b>M</b>	1 μs	<b>Q</b>	6.4 μs

For maximum speed table refer to [Maximum speed calculator for SpinCo radial magnetic rings](#).

### Test method to confirm maximum speed:

To verify of the prescribed speeds, the magnetic rings were first exposed statically at least 5 % above the temperature characteristics for a specified time and then rotated above their prescribed speed for 1 h.

# Communication interfaces

## Analogue output signals (1 V<sub>pp</sub>)

2 channels V<sub>1</sub> and V<sub>2</sub> differential sinusoidals (90° phase shifted) and differential, rectangular index pulse V<sub>0</sub>

### Specifications

<b>Power supply *</b> (voltage at readhead)	5 V ±10 %	
	Reverse polarity and overvoltage protected	
<b>Current consumption</b>	<50 mA (without load)	
<b>Voltage drop over cable</b>	~ 24 mV/m (without load)	
	~ 30 mV/m (with 120 Ω load)	
<b>Output signals</b>	V <sub>1</sub> , V <sub>2</sub> , V <sub>0</sub>	Short circuit protected
<b>Sine / cosine signals</b>	<b>Amplitude</b> (with 120 Ω termination)	0.6 V <sub>pp</sub> to 1.2 V <sub>pp</sub>
	<b>Phase shift</b>	90° ±1°
<b>Reference signal</b>	<b>Amplitude</b> (with 120 Ω termination)	0.8 V <sub>pp</sub> to 1.2 V <sub>pp</sub>
	<b>Position</b>	45° ±45°
	<b>Width</b>	360° ±180°
<b>Termination</b>	Z <sub>0</sub> = 120 Ω between associated outputs	
<b>Cable length *</b>	Max. 10 m	

\* Please consider voltage drop over cable.

### Timing diagram

Rotating in positive direction

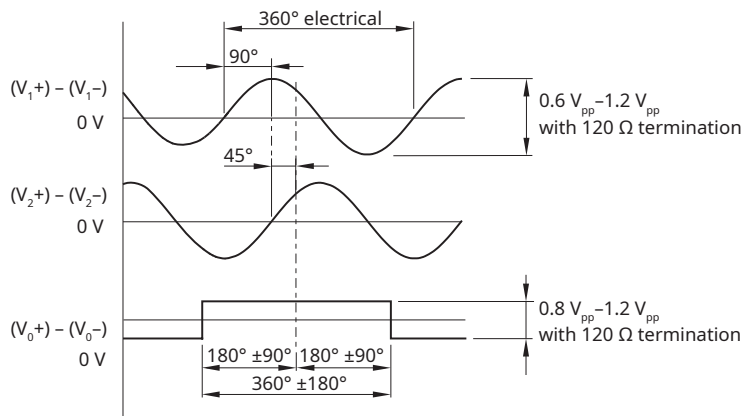

### Recommended signal termination

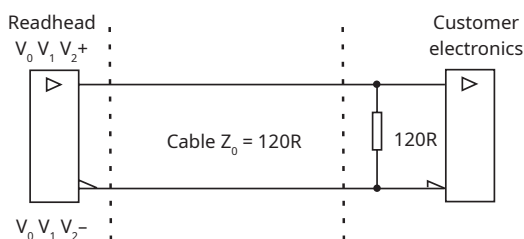

## Incremental quadrature output signals (ABZ)

### Specifications

<b>Power supply *</b>	5 V $\pm$ 10 % - voltage on readhead Reverse polarity and overvoltage protected
<b>Current consumption</b>	<50 mA (without load)
<b>Voltage drop over cable</b>	~ 24 mV/m (without load) ~ 65 mV/m (with 120 $\Omega$ load)
<b>Output signals</b>	3 square-wave signals A, B, Z and their inverted signals A-, B-, Z-
<b>Reference signal</b>	1 square-wave pulse Z and its inverted pulse Z-
<b>Signal level</b>	Differential line driver to EIA standard RS422: $U_H \geq 2.5$ V at $-I_H = 20$ mA $U_L \leq 0.5$ V at $I_L = 20$ mA
<b>Permissible load</b>	$Z_0 \geq 120 \Omega$ between associated outputs
<b>Cable length *</b>	Max. 10 m

\* Please consider voltage drop over cable.

### Timing diagram

Complementary signals not shown

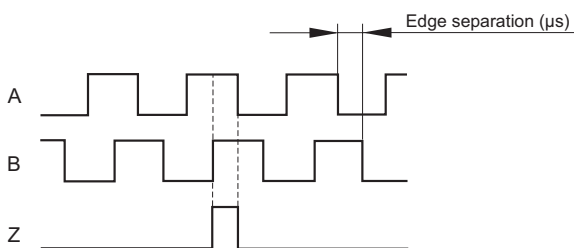

### Recommended signal termination

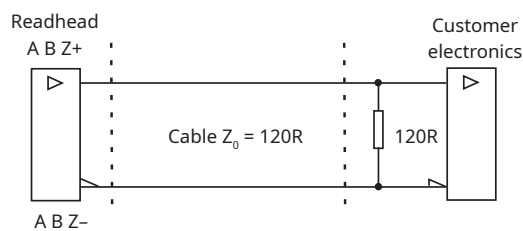

## Transient response of supply voltage

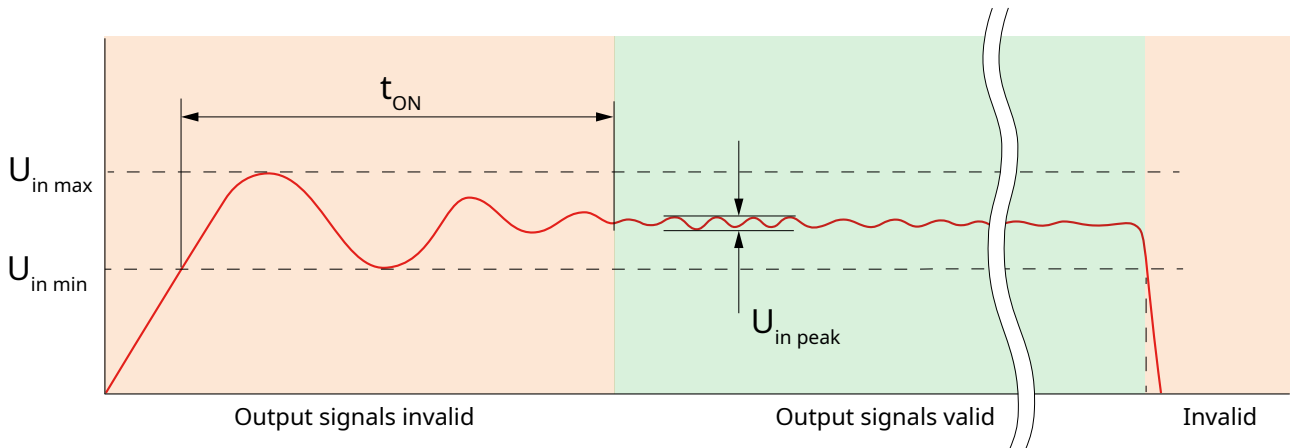

Switch-on/off behavior of the encoder:

After the switch-on time  $t_{ON}$ , valid output signals are available.

$$t_{ON} = 2\ s$$

$$U_{in\ max} = U_{in} + 10\ \%$$

$$U_{in\ min} = U_{in} - 10\ \%$$

If the power supply is switched off, or when supply voltage falls below  $U_{in\ min}$ , the output signals are also invalid.

The encoder requires a stabilized DC voltage supply  $U_{in}$ . The permissible ripple content of the DC voltage is:

- High frequency interference:  $U_{in\ peak} < 250\ mV$
- Low frequency ripple:  $U_{in\ peak} < 100\ mV$

The limits of the supply voltage must not be violated by ripple content.

The values apply as measured at the encoder. The voltage can be monitored and adjusted with the encoder's sensor lines, if available. If an adjustable power supply is not available, the voltage drop can be reduced by switching the sensor lines parallel to the corresponding supply wires.

# Part numbering

## Readhead

SP3 AS 1 E 000 A 1 A A 00

### Series

SP3 - SP3 flat readhead

### Communication interface

AS - Analogue voltage 1 V<sub>pp</sub>, wide reference, 5 V

IC - Incremental, RS422; 5 V

### Pole length

1 - 1 mm pole length

2 - 2 mm pole length

### Reference mark

E - With reference mark

### Resolution (steps per period)

000 - N/A (for AS only)	D04 - 40	D20 - 200	1D0 - 1000
02B - 4	06B - 64	08B - 256	10B - 1024
03B - 8	D08 - 80	D40 - 400	2D0 - 2000
04B - 16	D10 - 100	D50 - 500	11B - 2048
D02 - 20	07B - 128	09B - 512	4D0 - 4000
05B - 32	D16 - 160	D80 - 800	12B - 4096

### Minimum edge separation

A - N/A (for AS only)	G - 150 ns	M - 1 μs
B - 25 ns	H - 200 ns	N - 1.3 μs
C - 50 ns	I - 300 ns	O - 1.6 μs
D - 75 ns	J - 400 ns	P - 3.2 μs
E - 100 ns	K - 550 ns	Q - 6.4 μs
F - 125 ns	L - 800 ns	

### Cable length

A - 0.3 m	C - 1.5 m	3 - 3 m
B - 0.5 m	2 - 2 m	5 - 5 m
1 - 1 m	D - 2.5 m	F - 10 m

Other cable lengths available per special request. Minimum cable length is 10 cm, maximum cable length is 10 m.

### Cable outlet

A - Axial  
L - Left tangential  
R - Right tangential

### Connector

A - 9 pin D type plug	D - 15 pin D type plug
B - 12 pin M23 coupling connector	F - Flying lead
C - 12 pin M23 cable connector	N - 17 pin M23 type plug

### Special requirements

00 - No special requirements

Not all part number combinations are valid. Please refer to the table of available combinations on the next page.

**Table of available combinations**

Series	Output type	Pole length	Reference mark	Resolution	Minimum edge separation	Cable length	Cable outlet	Connector	Special requirements
SP3	AS	1 / 2	E	000	A	1 / 2 / 3 / 5 A / B / C / D / F	A / L / R	A / B / C / D / F / N	00
	IC			02B / 03B / 04B / 05B / 06B / 07B / 08B / D02 / D04 / D10 / D16 / D20 / D08	B / C / D / E / F / G / H / I / J / K / L / M / N / O / P / Q				
				09B / D40 / D50	B / C / D / E / F / G / H / I / J / K / L / M / N / O / P				
				10B / 1D0 / D80	B / C / D / E / F / G / H / I / J / K / L / M / N / O				
				2D0	B / C / D / E / F / G / H / I / J / K / L / M				
				11B	B / C / D / E / F / G / H / I / J / K / L				
				12B / 4D0	B / C / D / E / F / G / H / I / J				

## Magnetic ring

**MR 040 U 030 F 128 N 00**

### Series

**MR** - Magnetic incremental ring

### Outer diameter

**031** - 31 mm      **114** - 114 mm  
**040** - 40 mm      **127** - 127 mm  
**050** - 50 mm      **162** - 162 mm  
**063** - 63 mm      **176** - 176 mm  
**081** - 81 mm

### Cross section

**U** - Height 10 mm, radial magnetisation, fully welded cover foil  
**X** - Cross section defined under Special requirements

### Inner diameter

**020** - 20 mm      **095** - 95 mm  
**030** - 30 mm      **100** - 100 mm  
**040** - 40 mm      **143** - 143 mm  
**050** - 50 mm      **130** - 130 mm  
**060** - 60 mm

### Reference mark

**F** - GMR reference mark

### Number of poles

**050** - 50 poles      **160** - 160 poles      **400** - 400 poles  
**064** - 64 poles      **180** - 180 poles      **512** - 512 poles  
**080** - 80 poles      **200** - 200 poles      **556** - 556 poles  
**100** - 100 poles      **256** - 256 poles  
**128** - 128 poles      **360** - 360 poles

### Material

**N** - Martensitic stainless steel hub with bonded rubber tape, with cover foil

### Special requirements

**00** - No special requirements  
**29** - Height 15 mm, radial magnetisation, fully welded cover foil

Not all part number combinations are valid. The inner diameter of rings is related to the outer diameter and cannot be randomly selected. Please refer to the table of available combinations on the next page.

Other magnetic ring sizes available per special request.

**Table of available combinations**

Series	Outer diameter	Cross section	Inner diameter	Reference mark	Number of poles	Material	Special requirements
MR	031	U	020	F	050	N	00
					100		
	040		064				
			128				
	050		080				
			160				
	063		100				
			200				
			100				
			200				
	081		128				
			256				
	114		180				
			360				
	127		200				
			400				
162	256						
	512						
176	X	130		556		29	



## Head office

---

### RLS merilna tehnika d. o. o.

Poslovna cona Žeje pri Komendi  
Pod vrbami 2  
SI-1218 Komenda  
Slovenia

T +386 1 5272100  
E [mail@rls.si](mailto:mail@rls.si)  
[www.rls.si](http://www.rls.si)

## Global support

---

Visit our [website](#) to contact your nearest sales representative.

## Document issues

---

Issue	Date	Page	Description
4	16. 2. 2022	21	Hysteresis added
5	2. 2. 2023	4	Surface markings added
6	10. 7. 2023	24, 25	Max. length amended
7	25. 10. 2023	22	Connector options amended
		28	Table of available combinations amended
8	5. 7. 2024	6, 7	Encoder assembly with MR176X moved
		7	Installation tolerances moved
		17	Diameter for MR176X amended
		29	Table of available combinations amended
9	2. 12. 2024	8	Installation tolerances amended

This product is not designed or intended for use outside the environmental limitations and operating parameters expressly stated on the product's datasheet. Products are not designed or intended for use in medical, military, aerospace, automotive or oil & gas applications or any safety-critical applications where a failure of the product could cause severe environmental or property damage, personal injury or death. Any use in such applications must be specifically agreed to by seller in writing, and is subject to such additional terms as the seller may impose in its sole discretion. Use of products in such applications is at buyer's own risk, and buyer will indemnify and hold harmless seller and its affiliates against any liability, loss, damage or expense arising from such use. Information contained in this datasheet was derived from product testing under controlled laboratory conditions and data reported thereon is subject to the stated tolerances and variations, or if none are stated, then to tolerances and variations consistent with usual trade practices and testing methods. The product's performance outside of laboratory conditions, including when one or more operating parameters is at its maximum range, may not conform to the product's datasheet. Further, information in the product's datasheet does not reflect the performance of the product in any application, end-use or operating environment buyer or its customer may put the product to. Seller and its affiliates make no recommendation, warranty or representation as to the suitability of the product for buyer's application, use, end-product, process or combination with any other product or as to any results buyer or its customer might obtain in their use of the product. Buyer should use its own knowledge, judgment, expertise and testing in selecting the product for buyer's application, end-use and/or operating environment, and should not rely on any oral or written statement, representation, or samples made by seller or its affiliates for any purpose. EXCEPT FOR THE WARRANTIES EXPRESSLY SET FORTH IN THE SELLER'S TERMS AND CONDITIONS OF SALE, SELLER MAKES NO WARRANTY EXPRESS OR IMPLIED WITH RESPECT TO THE PRODUCT, INCLUDING ANY WARRANTY OF MERCHANTABILITY OR FITNESS FOR ANY PARTICULAR PURPOSE, WHICH ARE DISCLAIMED AND EXCLUDED. All sales are subject to seller's exclusive terms and conditions of sale which, where the seller is (a) RLS Merilna tehnika d. o. o., are available at <https://www.rls.si/eng/salesterms>, (b) Renishaw, Inc., are available at <https://www.renishaw.com/legal/en/-42186>, or (c) another person, are available on request, and in each case, are incorporated herein by reference, and are the exclusive terms of sale. No other terms and conditions apply. Buyer is not authorized to make any statements or representations that expand upon or extend the environmental limitations and operating parameters of the products, or which imply permitted usage outside of that expressly stated on the datasheet or agreed to in writing by seller.

RLS Merilna tehnika d. o. o. has made considerable effort to ensure the content of this document is correct at the date of publication but makes no warranties or representations regarding the content. RLS Merilna tehnika d. o. o. excludes liability, howsoever arising, for any inaccuracies in this document. © 2024 RLS d. o. o.