

RE22 series rotary encoders



The RE22 is a compact, high-speed rotary magnetic encoder designed for use in harsh environments. The traditional design allows for easy integration to existing machines.

A magnet is mounted to the shaft within the encoder body. Rotation of this magnet is sensed by a custom encoder chip within the body, and processed to give the required output format.

The encoder chip processes the signals received to provide resolutions of up to 13 bit (8,192 positions per revolution) with high operational speeds. Output signals are provided in industry standard absolute, incremental, analogue or linear formats.

The compact encoder body is just 22 mm in diameter and provides dirt immunity up to IP68.

The RE22 can be used in a wide range of applications including marine, medical, print, converting, industrial automation, metal working and instrumentation.

Product range

RE22A - analogue with a single sine/cosine cycle per revolution

RE22B - complementary analogue outputs with a single sine/cosine cycle per revolution

RE22I - incremental with 80 to 2,048 pulses per revolution (320 to 8,192 counts per revolution with x 4 evaluation)

RE22S - synchro serial interface (SSI) with 320 to 8,192 positions per revolution

RE22P - absolute parallel interface with 512 positions per revolution (9 bit)

RE22V - linear voltage output in a range of variants

System features:

- Excellent immunity to IP68
- High speed operation to 20,000 rpm
- Compact - 22 mm diameter body
- Absolute - to 13 bit (8,192 positions per revolution)
- Industry standard absolute, incremental, analogue and linear output formats
- Accuracy to $\pm 0.3^\circ$
- Simple integration

RE22 installation drawing

Dimensions and tolerances in mm

IP64 / IP68

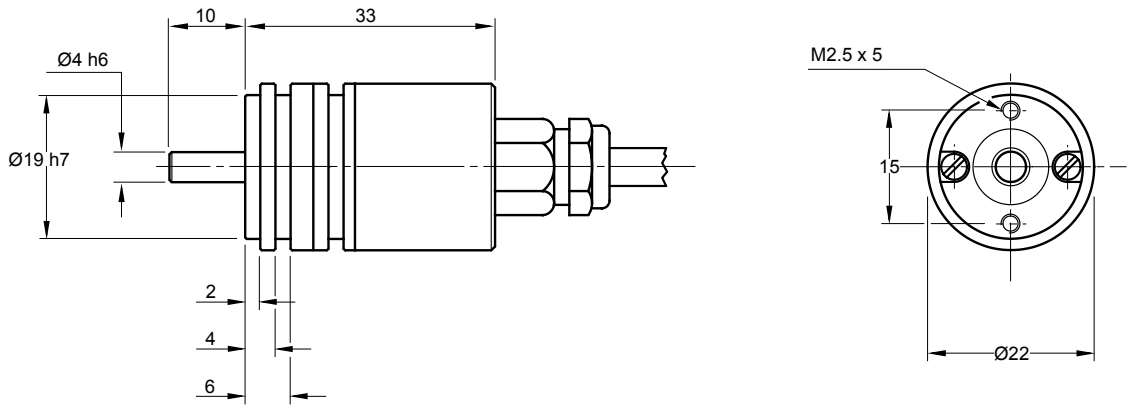

IP53

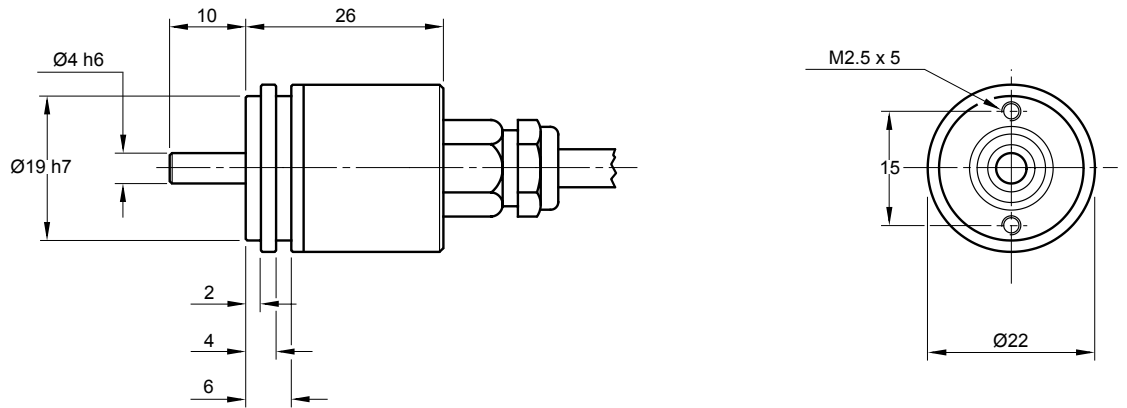
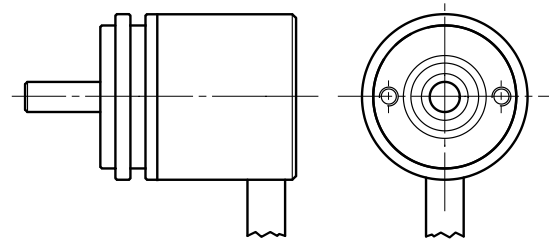

Table of expected bearing life ratings in hours

Speed (rpm)	Rad. load 5 N	Rad. load 10 N	Rad. load 15 N	Rad. load 20 N
500	205,401	98,455	54,569	33,333
1,000	102,700	49,227	27,285	16,667
2,000	51,350	24,613	13,642	8,333
5,000	20,540	9,845	5,457	3,333
10,000	10,270	4,923	2,728	1,667
15,000	6,847	3,282	1,819	1,111
20,000	5,135	2,461	1,364	833

Maximum recommended shaft loads: radial 20N, axial 10N

IP53 (alternative radial cable exit)



Operating and electrical specifications

Humidity (for IP64 version)	Storage 95% maximum relative humidity (non-condensing) (IEC 61010-1) Operating 80% maximum relative humidity (non-condensing) (IEC 61010-1)
Acceleration	Operating 500 m/s ² BS EN 60068-2-7:1993 (IEC 68-2-7:1983)
Shock (non-operating)	1000 m/s ² , 6 ms, 1/2 sine BS EN 60068-2-27:1993 (IEC 68-2-27:1987)
Vibration (operating)	100 m/s ² max at 55 to 2000 Hz BS EN 60068-2-6:1996 (IEC 68-2-6:1995)
EMV compliance	BS EN 61326
Cable	Outside diameter 5 mm
Mass	Encoder unit 1 m cable (no connector) IP53 axial cable 68 g, side cable 60 g. IP64/IP68 axial cable 73 g.
Environmental sealing NOTE:	IP53 (IP64/IP68 optional) BS EN 60529:1992 IP68 version must be operated immersed in fluid

RE22A – Analogue sinusoidal outputs

2 channels V_A V_B sinusoids (90° phase shifted, single ended)

Power supply	$V_{dd} = 5\text{ V} \pm 5\%$
Power consumption	20 mA
Outputs	Signal amplitude $2 \pm 0.2 V_{pp}$ Signal offset $\frac{V_{dd}}{2} \pm 5\text{ mV}$
Max. output frequency	333 Hz
Max. cable length	3 m
Connector options	9 pin 'D' type plug (standard) Flying lead
Temperature	Operating $-25\text{ }^\circ\text{C}$ to $+85\text{ }^\circ\text{C}$ Storage $-25\text{ }^\circ\text{C}$ to $+125\text{ }^\circ\text{C}$
Maximum speed	20,000 rpm
Internal serial impedance	720 Ω

Timing diagram

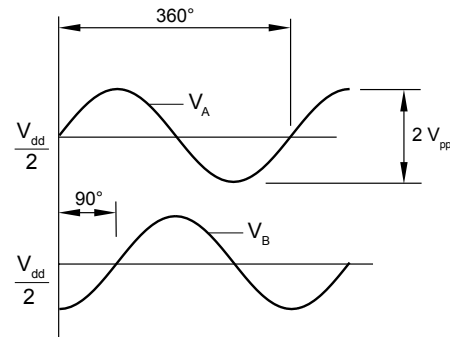

V_A leads V_B by 90° for clockwise rotation of shaft



RE22B – Analogue complementary sinusoidal outputs

2 channels V_A and V_B differential sinusoids in quadrature (90° phase shifted)

Power supply	$V_{dd} = 5\text{ V} \pm 5\%$
Power consumption	20 mA
Outputs	Signal amplitude $0.5 \pm 0.1 V_{pp}$ Signal offset $\frac{V_{dd}}{2} \pm 5\text{ mV}$
Max. output frequency	333 Hz
Max. cable length	20 m
Connector options	9 pin 'D' type plug (standard) Flying lead
Temperature	Operating $-25\text{ }^\circ\text{C}$ to $+85\text{ }^\circ\text{C}$ Storage $-25\text{ }^\circ\text{C}$ to $+125\text{ }^\circ\text{C}$
Maximum speed	20,000 rpm
Internal serial impedance	100 Ω

Timing diagram

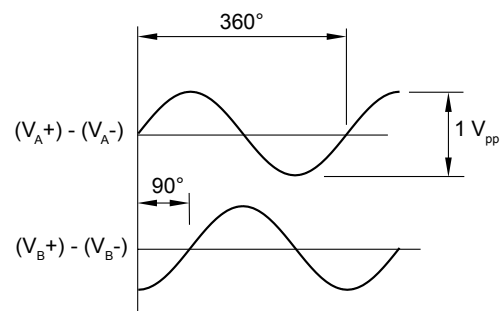

V_A leads V_B by 90° for clockwise rotation of shaft



Data sheet
RE22D01_01

RE22I – Incremental outputs

Square wave differential line driver to RS422A

Power supply	$V_{dd} = 5\text{ V} \pm 5\%$
Power consumption	23 mA for 9 bit resolution 35 mA for all other resolutions
Output signals	A, B, Z, A-, B-, Z- (RS422A)
Max. cable length	50 m
Connector options	9 pin 'D' type plug (standard) Flying lead
Temperature	Operating -25 °C to +85 °C Storage -25 °C to +125 °C
Edge separation	Min. 1 μs

Resolution options (counts per rev)	Maximum speed (rpm)	Accuracy*	Hysteresis
320, 400, 500	20,000	$\pm 0.5^\circ$	0.18°
512	20,000	$\pm 0.5^\circ$	0.45°
800, 1,000, 1,024	20,000	$\pm 0.3^\circ$	0.18°
1,600, 2,000, 2,048	10,000	$\pm 0.3^\circ$	0.18°
4,096	5,000	$\pm 0.3^\circ$	0.18°
8,192	2,500	$\pm 0.3^\circ$	0.18°

* Worst case within operational parameters including magnet position and temperature.

Timing diagram

(complementary signals not shown)

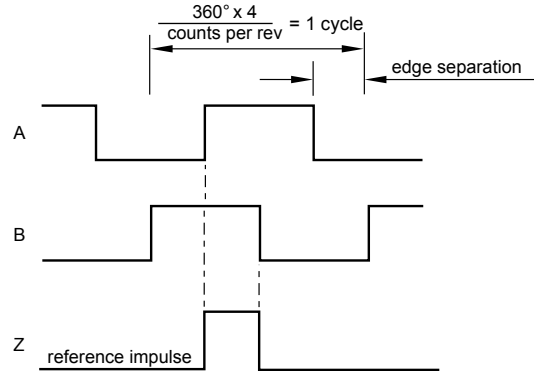

Recommended signal termination

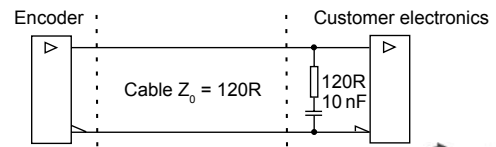

B leads A for clockwise rotation of shaft

RE22S – Absolute binary synchro-serial interface (SSI)

Serial encoded absolute position measurement

Output code	Natural binary
Power supply	$V_{dd} = 5\text{ V} \pm 5\%$
Power consumption	23 mA for 9 bit resolution 35 mA for all other resolutions
Repeatability	$\leq 0.07^\circ$
Data outputs	Serial data (RS422A)
Data inputs	Clock (RS422A)
Max. cable length	100 m (at 1 MHz)
Connector options	9 pin 'D' type plug (standard) Flying lead
Temperature	Operating -25 °C to +85 °C Storage -25 °C to +125 °C

Resolution options (positions per rev)	Maximum speed (rpm)	Accuracy*	Hysteresis
320, 400, 500	20,000	$\pm 0.5^\circ$	0.18°
512	20,000	$\pm 0.5^\circ$	0.45°
800, 1,000, 1,024	20,000	$\pm 0.3^\circ$	0.18°
1,600, 2,000, 2,048	10,000	$\pm 0.3^\circ$	0.18°
4,096	5,000	$\pm 0.3^\circ$	0.18°
8,192	2,500	$\pm 0.3^\circ$	0.18°

* Worst case within operational parameters including magnet position and temperature.

Timing diagram

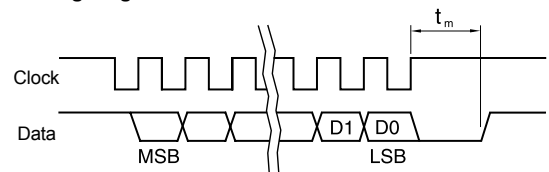

Clock $\leq 900\text{ kHz}$ $16\ \mu\text{s} \leq t_m \leq 22\ \mu\text{s}$ (for 9 bit resolution)
 Clock $\leq 4\text{ MHz}$ $12.5\ \mu\text{s} \leq t_m \leq 20.5\ \mu\text{s}$ (for all other resolutions)

Recommended signal termination

(For data output lines only)

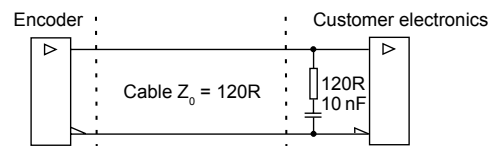

Position increases for clockwise rotation of shaft

RE22P – Binary parallel interface

Parallel absolute position measurement

Output code	Natural binary
Power supply	$V_{dd} = 5\text{ V} \pm 5\%$
Power consumption	20 mA without load
Output voltage	$V_H \geq 4\text{ V}$ at $-I_H \leq 3\text{ mA}$ $V_L \leq 1\text{ V}$ at $I_L \leq 3\text{ mA}$
Resolution	9 bit (512 positions per revolution)
Hysteresis	0.45°
Accuracy	±0.7°
Repeatability	≤ 0.07°
Data outputs	D0 (LSB) - D8 (MSB)
Data inputs	LE - latch enable input signal, active high Maximum sampling rate 500 kHz
Max. cable length	30 m
Connector options	15 pin 'D' type plug (standard) Flying lead
Temperature	Operating -25 °C to +85 °C Storage -25 °C to +125 °C
Maximum speed	20,000 rpm

Timing diagram

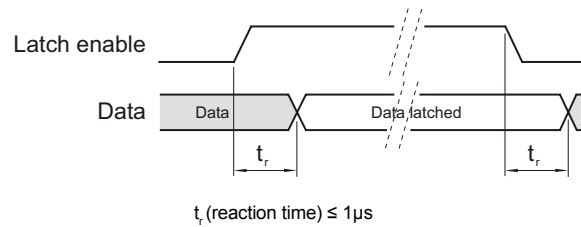

Position increases for clockwise rotation of shaft

RE22V – Linear voltage output

Power supply	$V_{dd} = 5\text{ V} \pm 5\%$
Power consumption	20 mA typical
Output voltage	0 V to V_{dd}
Output loading	Max. 10 mA
Nonlinearity	1 %
Max. cable length	20 m
Connector options	9 pin 'D' type plug (standard) Flying lead
Temperature	Operating -25 °C to +85 °C Storage -25 °C to +125 °C
Maximum speed	20,000 rpm

Electrical output/shaft position

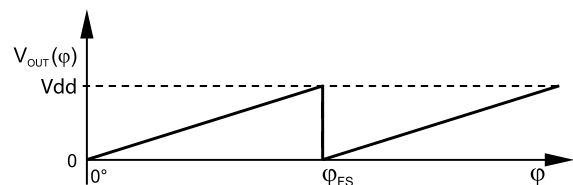

Output type and electrical variant

ϕ_{FS}	360°	180°	90°	45°
CW	VA	VB	VC	VD
CCW	VE	VF	VG	VH



Image shows clockwise rotation of shaft

RE22 ordering code



Encoder part number
 eg **RE22SC0409B10A3A00**

RE22 SC 04 09B 10 A 3 A 00

Output type

- AC** - Analogue sinusoidal 2 Vpp
- BC** - Analogue complementary sinusoidal
- IC** - Incremental/RS422A
- PC** - Absolute binary parallel
- SC** - Absolute binary synchro - serial (SSI)
- V_x** - Linear voltage:

Linear voltage output 0 V to 5 V, supply 5 V DC				
	360°	180°	90°	45°
CW	VA	VB	VC	VD
CCW	VE	VF	VG	VH

Shaft size
04 - 4 mm

Resolution
09B - 512 counts or positions per rev
 (one sine/cosine wave per revolution – for output types **AC** and **BC**)

IC and SC only

Decimal
D32 - 320 **D80** - 800 **2D0** - 2,000
D40 - 400 **1D0** - 1,000
D50 - 500 **1D6** - 1,600

Binary
09B - 512 **11B** - 2,048 **13B** - 8,192
10B - 1,024 **12B** - 4,096

Cable length
10 - 1 metre

Special requirements
00 - None

Environment

- A** - IP53, Aluminium body (standard)
- B** - IP64, Aluminium body (for body style **3** only)
- C** - IP68, Aluminium body (for body style **3** only)

Body style and cable exit

- 2** - Cylindrical body, radial cable exit
- 3** - Cylindrical body, axial cable exit

Connector option

- A** - 'D' type connector - 9 way
- B** - 'D' type connector - 15 way (for output type **PC** only)
- F** - Flying lead (no connector)

NOTE: Not all combinations are valid.

Head office

RLS merilna tehnika d.o.o.
Cesta II. grupe odredov 25
SI-1261 Ljubljana - Dobrunje
Slovenia

T: +386 1 5272100
F: +386 1 5272129
E: mail@rls.si
www.rls.si

Document issues

Issue	Date	Page	Corrections made
1	13. 1. 2009	-	New layout

RENISHAW  is our worldwide sales support partner for Magnetic Encoders.

Australia

T +61 3 9521 0922
E australia@renishaw.com

Austria

T +43 2236 379790
E austria@renishaw.com

Brazil

T +55 11 4195 2866
E brazil@renishaw.com

Canada

T +1 905 828 0104
E canada@renishaw.com

The People's Republic of China

T +86 10 8448 5306
E beijing@renishaw.com

Czech Republic

T +420 5 4821 6553
E czech@renishaw.com

France

T +33 1 64 61 84 84
E france@renishaw.com

Germany

T +49 7127 9810
E germany@renishaw.com

Hong Kong

T +852 2753 0638
E hongkong@renishaw.com

Hungary

T +36 23 502 183
E hungary@renishaw.com

India

T +91 20 6674 6751
E india@renishaw.com

Israel

T +972 4 953 6595
E israel@renishaw.com

Italy

T +39 011 966 10 52
E italy@renishaw.com

Japan

T +81 3 5366 5316
E japan@renishaw.com

The Netherlands

T +31 76 543 11 00
E benelux@renishaw.com

Poland

T +48 22 577 11 80
E poland@renishaw.com

Russia

T +7 495 231 1677
E russia@renishaw.com

Singapore

T +65 6897 5466
E singapore@renishaw.com

Slovenia

T +386 1 52 72 100
E mail@rls.si

South Korea

T +82 2 2108 2830
E southkorea@renishaw.com

Spain

T +34 93 663 34 20
E spain@renishaw.com

Sweden

T +46 8 584 90 880
E sweden@renishaw.com

Switzerland

T +41 55 415 50 60
E switzerland@renishaw.com

Taiwan

T +886 4 2473 3177
E taiwan@renishaw.com

UK

T +44 1453 524524
E uk@renishaw.com

USA

T +1 847 286 9953
E usa@renishaw.com

**For all other countries
Please contact RLS' head
office**

T +386 1 52 72 100
E mail@rls.si