

# LM13ASC00 scale guide

## Scale applicator tool for LM13 readhead installations

The LM13ASC00 scale guide is mounted in place of any RLS LM13 readhead and uses motion of the axis to apply MS10 tape scale parallel to the guideway - a one man, one hit operation.

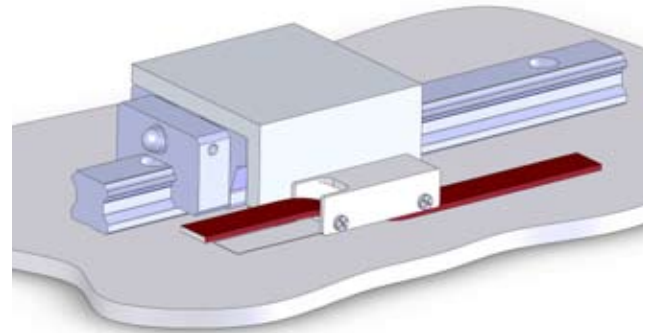

## Scale installation

### 1 Prepare scale and surface

- Ensure scale is cut to correct length and mounting surface has been cleaned.

### 2 Install the scale guide

- Mount the scale guide to the readhead bracket as shown in figure 1.

Figure 1

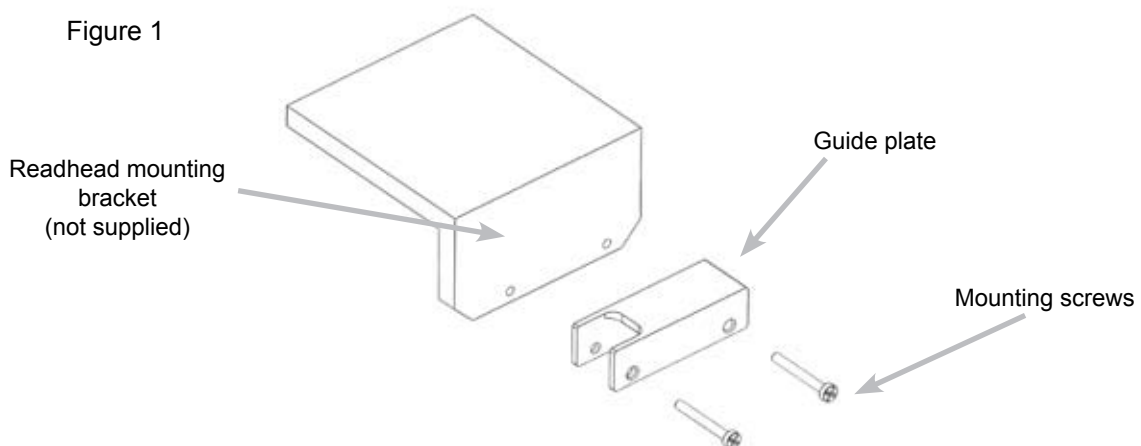

### 3 Load the scale into the scale guide

- Separate the backing paper from the first 40 mm of scale and feed it into the scale guide.
- Push the scale carefully through to the end of scale mark, ensuring that it does not stick to the mounting surface until it is in position. **NOTE:** to prevent the scale sticking to the mounting surface during this operation it may be necessary to re-apply approximately 20 mm of backing paper to the end of the scale before inserting through scale guide.
- Attach the end of the scale to the mounting surface with light finger pressure.

Figure 2

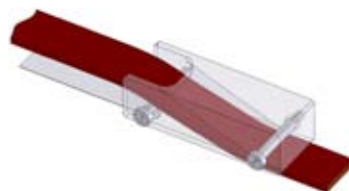

### 4 Apply the scale

- Traverse the axis through its full travel at a slow, steady speed.
- While moving the axis:
  - Apply a light finger pressure to the scale behind the scale guide to attach it to the mounting surface.
  - Gently pull the backing paper away from in front of the scale guide as it is separated.

## 5 Remove the scale guide

- When the axis has reached the limit of its travel, lock the axis in place and unbolt the scale guide from the readhead mounting bracket.

## 6 Ensure complete adhesion

- Apply firm finger pressure along the full length of the scale from the centre outwards to each end.

## 7 Apply cover foil (if used)

- Install as per scale installation instructions in step 2 onwards. Cover foil can be installed to extend over the end of the scale and onto the substrate.

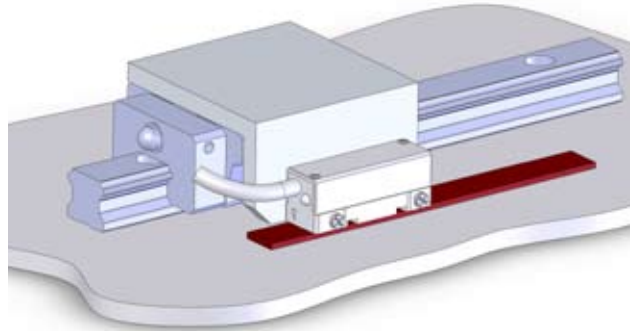

## Scale installation drawing

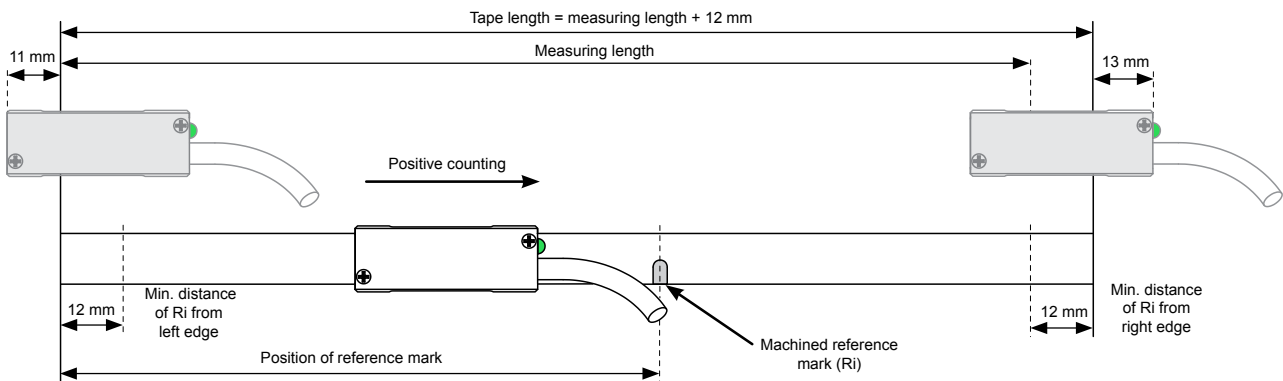

## Scale handling precautions

**WARNING:** The MS10 magnetic scale should not be exposed to magnetic flux densities higher than 50 mT on its surface. Magnetic fields higher than 50 mT can damage the scale.

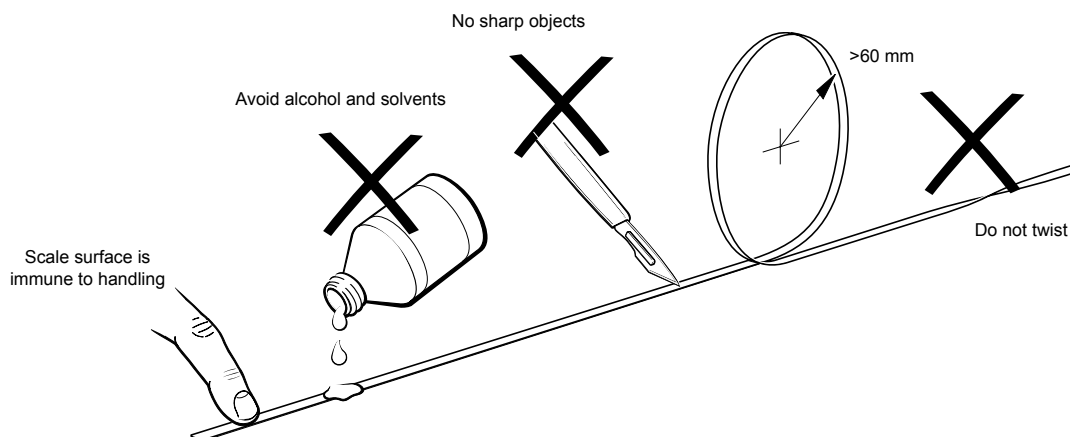

**DO NOT** remove the scale for refitting or use elsewhere once it has been applied to the mounting surface. The scale can be applied once only.